

AUGUST 1983

\$5.00

BME

BROADCAST MANAGEMENT/ENGINEERING

THE 1983 BUYER'S GUIDE SOURCE

AUDIO
VIDEO
LIGHTING
TRANSMITTING
TEST AND MEASUREMENT
COMPONENTS, HARDWARE
SERVICES

0702 0371505 41 31
T M DENBROOK
DIR OF ENG
KUUW RADIO
325 CMU-U OF
SEATTLE WASHINGTON
LA ORIO

DIR

The Show-Stopper Stole the Show.

At the NAB '83 show, ADM Technology introduced the 9000 Series of Tele-production consoles – the newest, most advanced audio consoles in the industry. It was a smash hit! The 9000 Series brings together in one console a quantum leap in audio processing and control as well as ADM's unsurpassed reliability. The 9000 is a true stereo console with a microprocessor-based, random access, line level input router. Together with its computer con-



trolled output assignments, the 9000 will store in its non-volatile memory 99 input/output assignments. Designed for television production, post-production and on-air broadcast, the 9000 is compatible with SMPTE's emerging standards. Like all ADM consoles, it is backed by our exclusive 5-Year Warranty. For more information, contact ADM Technology, Inc., 1626 E. Big Beaver Road, Troy, MI 48084. Phone: (313) 524-2100. TLX 23-1114.



ADM[®]
The
Audio
Company

WEST CENTRAL SALES
(817) 467-2990

WEST COAST SALES
(415) 945-0181

MAIN OFFICE AND
EAST COAST SALES
(313) 524-2100

Small Surprise.



Now a color monitor with every feature you'd expect from BARCO joins our CM Production Series.

The respected BARCO CM Series is coming down in size. And our new small surprise, the CM 22, has the same features as the established 13" and 19" CM monitors, and more.

Put them in your remote vans. Use them in those tight spaces where the distance between viewer and monitor is limited, but the need is for the ultimate in color.

The CM 22 can operate on 110V or 220V mains and 12V local supplies and comes equipped with a fine pitch dot, black matrix in-line gun tube. The rack mount version makes it possible to install two 9" monitors in a single 19" rack. The switch mode power

supply allows stable performance in areas where the main supply may vary under certain conditions.

Features found in the 9", 13", and 19" CM models include: pulse cross; pre-set contrast, hue, saturation, brightness; automatic degaussing; scan format switch; set up switch; front accessible RGB cut off and gain controls. Modular construction allows for quick and easy maintenance.

For more information on our small surprise, the CM 22, and the rest of the BARCO video monitor line, call Chris Golson at 201/882-0584.

When your image is everything...turn to BARCO. Available in the U.S....only from ELECTOR.

ELECTOR USA, INC.

In The U.S., Elector USA, Inc., 5128 Calle del Sol, Santa Clara, CA 95050 Phone: 408/727-1506 30 Chapin Road,
P.O. Box 699, Pine Brook, NJ 07058 Phone: 201/882-0584 In Canada, Electro & Optical Systems, Ltd., 31
Progress Court, Scarborough, Ontario M16 3V5 Phone: 416/439-9333

HOW TO TECHNOLOGICALLY ADVANCE YOUR BOTTOM LINE.

You are looking at what many experts believe to be two of the most effective forms of investment spending in the industry today.

The Sony BVE-5000 editor and BVH-2000 recorder. Two extraordinary machines created for a single and simple purpose:

To help you shuttle more customers in and out of your facility than ever before.

THE FIRST THING THEY EDIT IS DOWNTIME.

Every day, in countless production facilities around the country, \$400-an-hour editing suites are reduced to high-priced waiting rooms by

editing systems that fail to function.

Leaving anxious facility owners and disgruntled clients making small talk instead of headwagging. While they ponder an all-too-common question: "How long will we be down this time?"

Thanks to the Sony editing system, this scenario is rarely, if ever, played out in leading production houses like Broadway Video, Videoworld, JSL and a host of others currently using it.

The reason?

"Sony belongs to a small group of manufacturers that still think of broadcast equipment as product, not an experiment," says Frank Herold.



Chief editor of Videoworks in New York.

"When you take a piece of Sony equipment out of the box and plug it in, an amazing thing happens. It works!"

And keeps working. Faster. Easier. And more precisely than any other system.

THE MOST INTELLIGENT CONVERSATION YOU'LL EVER HAVE WITH A MACHINE.

Today, there are any number of people trying to compete in this, a communications industry, with machines that can't even communicate with each other.

An irony not lost on all those who have invested in the equipment you see here.

All elements of the Sony editing system have been programmed to speak to each other fluently, and to understand each other perfectly.

With absolutely nothing lost in translation or transmission.

You'll find that they're geared to speak equally well with Sony's Beta® and U-matic® recorders.

Not to mention with you. The system's high-resolution CRT screen provides clear, easy-to-follow instructions. Asks questions when you haven't been explicit enough, and delivers the most comprehensive, and yet, comprehensible display in the industry.

A MYRIAD OF FUNCTIONS WITHOUT A MYRIAD OF BUTTONS.

The BVE-5000 control panel has the capacity

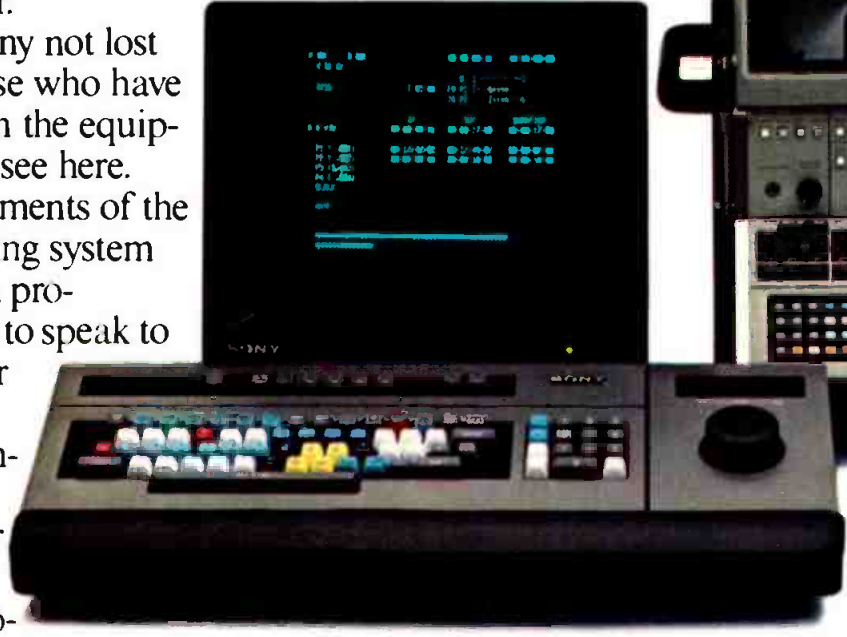

to make an editor feel like an editor, not like a typist.

Strikingly short of buttons, the system is in no way short of features. Offering dynamic tracking. Variable speed search. Full Biderex Jog. And Vertical Interval Time Code.

Each of which, like everything else in the Sony system, helps to push profits in a rather vertical direction.

For more information contact Sony Broadcast in New York/New Jersey at (201) 368-5085; in Chicago at (312) 773-6045; in Los Angeles at (213) 841-8711; in Atlanta at (404) 451-7671; or in Dallas at (214) 659-3600.

SONY

Broadcast

Sony, U-matic and Beta are registered trademarks of the Sony Corp. © 1983 Sony Corp. of America, 9 W. 57th St., New York, NY 10019.



CHYRON AT CAMERA MART:

WHERE YOU'LL FIND THE BEST NAMES IN VIDEO.

CHYRON VP-1



ACTUAL VP-1 GENERATED GRAPHICS PHOTOGRAPHED FROM A MONITOR

Chyron VP-1 Character Generator: Astounding Capability at an Affordable Price.

The Chyron VP-1 is a broadcast quality generator that gives you superb image resolution: crisp, clear characters and an extraordinary range of special effects usually found in units costing far more.

Use the VP-1 with any micro-computer to achieve exciting, creative visuals and titles for all your video graphics: news, weather, election results, advertising, training, sales presen-

tations and educational aids.

You get two fonts supplied, expandable to six; eight colors from a palette of 64, for characters background and edging, plus extensive common capability, including font selection, color selection, placement, spacing, italics and many, many more!

In New York see the Chyron VP-1 *only at Camera Mart!*

The Camera Mart, Inc.

456 West 55th Street, New York 10019 • (212) 757-6977/Telex: 1-2078
Video Department: 800 Tenth Avenue
Sales • Service • Rental

Circle 101 on Reader Service Card

BM/E

BROADCAST MANAGEMENT/ENGINEERING

Publisher
Charles C. Lenz, Jr.
Editor Emeritus
James A. Lipke

Editorial Director
Gerald M. Walker

Editor
Robert Rivlin
Senior Editor
Robin Lanler
Senior Associate Editor
Eva J. Blinder
Associate Editor
Tim E. Wetmore
Copy/Research Editor
Allene J. Roberts
Assistant to the Editor
Douglas Damoth
Editorial Assistant
Torla Smith

FCC Counsel
Farmer, McGuinn, Flood, Bechtel & Ward
Broadcast Financial Consultant
Mark E. Battersby
Special Projects Editor
C. Robert Paulson

Associate Publishers
Djuna Van Vort
Neal Wilder
Production Director
Janet E. Smith
Creative Consultant
Mark Rogan
Advertising Coordinator
Dana L. Kurtz
Marketing Assistant
Elaine Allimonti
Reader Service
Sharon Porges

Controller
Michael J. Lanni

BROADBAND INFORMATION SERVICES, INC.
295 Madison Ave., New York, N.Y. 10017
212-685-5320, Telex: 64-4001
Publishers of:
BM/E—Broadcast Management/Engineering
BM/E's World Broadcast News

☆ABP **BM/E BROADCAST MANAGEMENT ENGINEERING** (ISSN 0005-3201) is published monthly by Broadband Information Services Inc. All notices pertaining to undeliverable mail or subscriptions should be addressed to 295 Madison Ave., New York, NY 10017. BM/E is circulated without charge to those responsible for station operation and for specifying and authorizing the purchase of equipment used in broadcast facilities in the U.S. and Canada. These facilities include AM, FM and TV broadcast stations, CATV systems, ETV stations, networks and studios, audio and video recording studios, telecine facilities, consultants, etc. Subscription prices to others \$24.00 one year, \$36.00 two years. Foreign \$36.00 one year, \$60.00 two years. Air Mail rates on request. Copyright 1983 by Broadband Information Services, Inc., New York City. Second class postage paid N.Y., N.Y. and additional mailing offices.

The best there is!

The SDS-2 Signal Distribution System

The perfect blend of hardware and software for versatile, flexible and truly expandable signal routing.

Compare these features:

- Classical design... one crosspoint for every path.
- Highest density crosspoint array.
 - 2048 crosspoints in only 8 RUs.
 - 96x96 video plus audio with redundant power supplies in only 72 RUs.
- Field expandable from 32x32 up to 512x512.
- Reliable Hybrid circuits for video crosspoints.
- Audio processing fully balanced.
- MicroPatch™ software includes Breakaway, Status Display, I/O Locks, Real Time Salvos... standard with the SDS-2.
- Control... varied and flexible for easy expansion and system reconfiguration.
- The most competitive cost per crosspoint.

Find out why the SDS-2 is the best there is. Call or write today.



CENTRAL DYNAMICS

Central Dynamics, 401 Wynn Drive, Huntsville, AL 35805 (205) 837-5180
New York: (914) 592-5440, Chicago: (312) 991-4720, Los Angeles: (213) 766-8185
Montreal: 147 Hymus Blvd., H9R 1G1 (514) 697-0810. Toronto (416) 446-1543

Circle 102 on Reader Service Card



BM/E CONTENTS

THE 1983 BUYER'S GUIDE SOURCE

THE SOURCE 1983 BUYER'S GUIDE	25	ALPHABETICAL LISTING OF MANUFACTURERS	59
INSTANT SOURCE LOCATOR INDEX	27	LOCAL REPS/DISTRIBUTORS	151

DEPARTMENTS

Editorial Cable at the Crossroads	8	Great Idea Contest	179
Broadcast Industry News Competition Is Concern in TV Deregulation Proposal; Editel Speeds Telecine Setup with Kodak's Analysis Film; FCC Adds FM Assignments But Delays Implementation	12	Business Briefs	186

COMING IN
SEPTEMBER
SPECIAL REPORT:
ENG AND ENA

INTRODUCING THE NEW PRIMUS™ AUDIO COMPONENTS

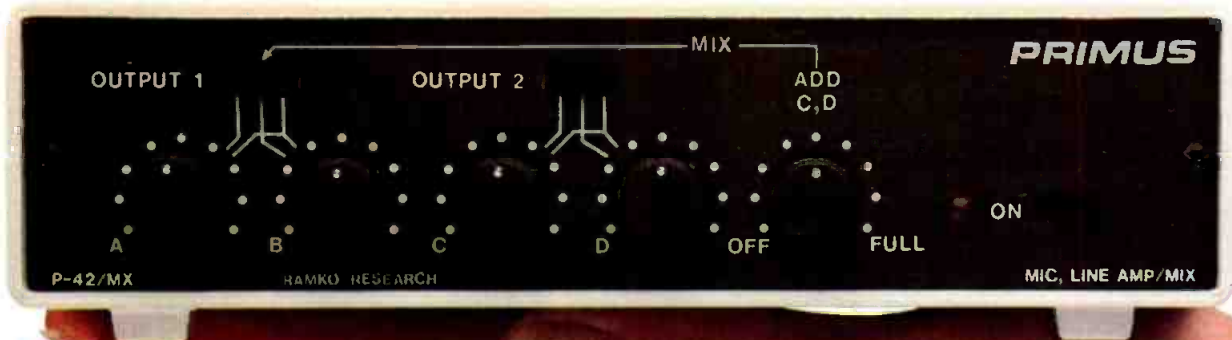

**CERTIFIED
PERFORMANCE**

Powerful performance in the palm of your hand.

PRIMUS (Pree-mūs): an array of compact, performance-engineered audio electronics from Ramko Research.

The new PRIMUS components are unlike any professional audio equipment you've ever used. Never before has so much advanced performance been put into such compact and rugged packages. Rarely have you had available so many features and options to help get the job done. Never have you had a three-year warranty that's backed up by factory certified proof-of-performance.

PRIMUS is a comprehensive range of components that give you the flexibility to configure an audio system limited only by your imagination. Whether you choose from tabletop or rack mounting versions, there's hardly an audio job that can't be improved upon.

Here's a partial list of models currently available:

- Lab standard mono or stereo turntable preamplifiers.
- Dual and quad input, gain selectable microphone/line amplifier mixers.
- Audio distribution amps from three (3) stereo/six (6) mono up to eight (8) stereo/sixteen (16) mono outputs. All models feature individual recessed front panel adjustments or optional high resolution, conductive plastic potentiometers.
- Mic/Line equalizer amplifiers with balanced I/O and up to ± 15 db of reciprocal equalization.
- Expandable audio console mixers with cueing, selectable EQ, metering phones and monitor.
- Voicegard™ combination limiter/compressor, noise gate with variable threshold and slope ratio; gain reduction metering.
- Signal processing VCA's with six (6) independently controlled channels. DC remote control with balanced outputs.
- R/P and playback, stereo and mono NAB cart machines.

Whichever combination of precision PRIMUS audio components you choose, you're guaranteed outstanding specifications. For example, our stereo turntable preamplifier measures:

Signal-to-noise Ratio: -93 dB (A weighted)
 Total Harmonic Distortion: Below .0018%
 Frequency Response: 10 Hz to 20 kHz, ± 25 dB
 Stereo Separation: -70 dB @ 1 kHz
 Output Level: $+25$ dBm (10 Hz - 20 kHz)

The simplified and modular packaging of PRIMUS allows us to concentrate the quality where it belongs: in state-of-the-art circuitry. High slew-rate integrated circuits and extensive ground planes insure the highest RFI protection.

All IC's plug into gold plated sockets. All models feature quick disconnect I/O connectors and require only 1 3/4 inch standard rack height.

We've taken another important step, too.

When you invest in PRIMUS, you receive a *Certified Performance Gold Card* that instantly puts you in touch with our Technical Assistance Department on a toll-free line. Just call in your registered serial number and you're in touch with the advice you need.

To put PRIMUS audio components to task on a free two-week trial, call toll free (800) 821-2545 or contact your nearest Ramko Research sales representative or distributor. Put the powerful performance of PRIMUS in the palm of your hand.



PRIMUS audio components are an array of compact, performance-engineered rack mounting or tabletop packages.



PRIMUS is a division of Ramko Research, Inc. 11355-A Folsom Blvd., Rancho Cordova, California 95670

(916) 635-3600

Circle 103 on Reader Service Card

© 1983 Ramko Research

Cable at the Crossroads

THE TIMING WAS PERFECT. Just as the cable TV industry was meeting in Houston for its annual convention, the Senate passed S.66, a bill aimed at making uniform the crazy quilt franchise regulations imposed by states and municipalities. Cable operators were jubilant, but looked warily ahead to the House vote where passage did not seem as certain.

By dint of a lot of hard work and months of negotiations between the NCTA and the National League of Cities, the cable industry gained the satisfaction of clearing the first legislative hurdle. But before the cheering had subsided, convention attendees were being warned that there is more hard work ahead if the cable industry is to live up to its promise.

The observations of Federal Communications Commission chairman Mark Fowler at the NCTA were apt. "We need a national cable law. We need enlightened local regulation that emphasizes regulatory restraint and thoughtful demands. And we need a cable industry that can be trusted to fulfill the promises it makes. These are difficult objectives, but they are by no means impossible," he said.

The promises cable operators make can be fulfilled, but according to a research project commissioned by NCTA, cable has a problem perhaps more disturbing than regulation, technology, or new competition. Opinion Research Corporation found that large segments of consumers are not being motivated to subscribe to cable and do not perceive cable as worth the price.

As NCTA president Tom Wheeler warned, "Even though we've finally reached the market and though Congress may be on the brink of providing us with richly deserved regulatory relief, not for one minute can we expect the consumer to beat a path to our door."

Wheeler told the industry that it has to build that path. To marketers, building the path means a large, national promotion campaign. But operator management and engineering should take a broader view. They should be asking if the path to the consumer is supported by a well-designed and constructed system. Not just to "get by," but to deliver what the marketing campaign promises.

Moreover, if cable is to become a part of the community, as FCC Chairman Fowler advised, what is the status of local origination? It appears that the pizzazz of the satellite-delivered services has just about overshadowed local origination programming that was a high priority a year ago. If consumers do not know what's on cable in general, they certainly cannot be expected to appreciate local origination. Again, cable operators should ask if local origination lacks an audience because of poor marketing or poor technical quality.

In calling for a "vigorous" cable industry, Chairman Fowler summed up the present situation saying, "It's time to pat yourselves [cable industry] on the back. But it's time for 'patting' yourselves somewhat harder and somewhat lower on the back as well. Get yourselves in gear for the challenges, in both regulation and technology, that the rest of this decade will surely present."

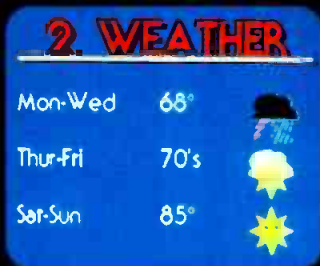

Keyboard Logo Compose.



Character Reduction.



Left/Right Italics.



Dual Channel.



Mirror Image.



Character Reversal.



Auto Camera Compose.



Sports Logos.

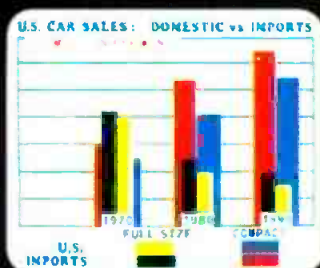

Business Statistics.



Computer Interface.



Background Figures.

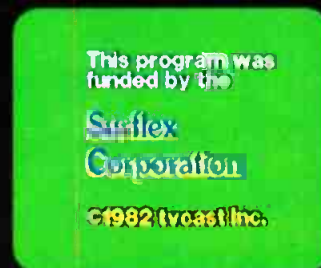

Character Outlining.

When you own a D-8800,
it's easy to show off.

With the 3M D-8800 Graphics Generator, you can do all this and more. It gives you ten roll and crawl speeds. Hundreds of fonts. Eight mask positions. Automatic centering, both horizontally and vertically. Generous storage capabilities. And the dynamics of animation. All without any add-ons.

Yet with all its capabilities, you don't need special training to run it. It's quick. It's easy. The keyboard language is simple English. And our optional

System Diagnostics package keeps your maintenance simple, too.

So give your productions the look of the top professionals. Show off with the D-8800.

All photos above are taken from actual TV monitors. If you'd like to see for yourself, call us collect at 1-612-733-8132 for a free demonstration. Outside the U.S., call 1-612-736-2549. Professional Audio Video Equipment/3M.



3M hears you ...

3M

**INTRODUCING THE
BECAUSE SHARP
THINK YOU SHOULD
MORE FOR AN**



***SHARP'S NEW DIODE GUN PLUMBICON**

Saticon is a registered trademark of NHK (Japan Broadcast Corp.) Plumbicon is a registered trademark of N.V. Philips.

XC-900D.* DOESN'T HAVE TO PAY IMAGE.

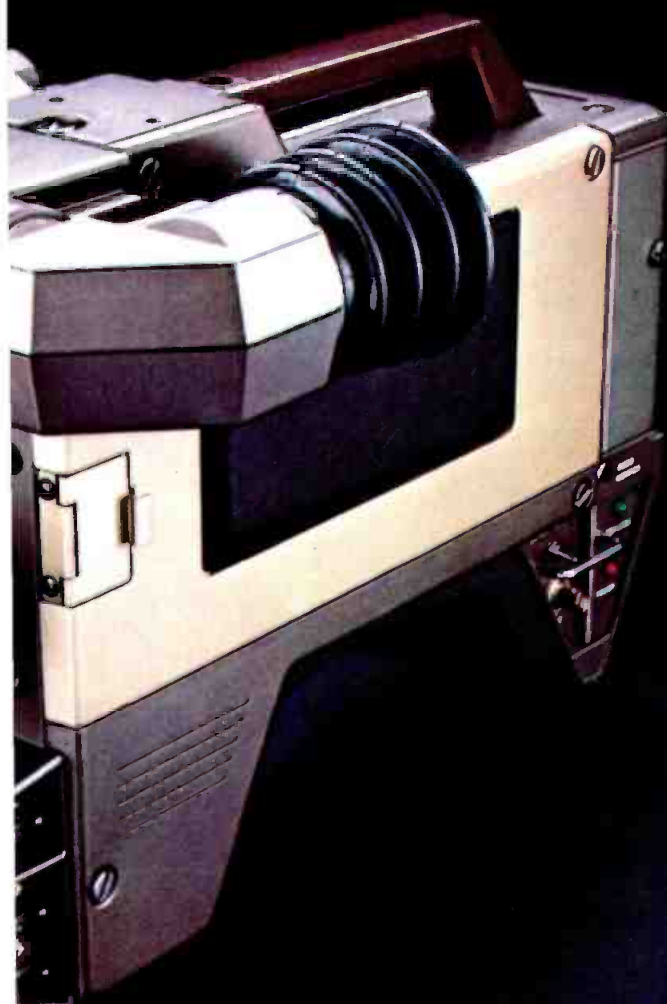

CON CAMERA.

If you think you have to pay through the viewfinder for a Diode Gun Plumbicon® camera, Sharp has a sensational surprise for your budget, the XC-900D.

Now it doesn't make sense to pay \$35,000 to \$45,000 for that image camera, when you can get the same state of the art technology for under \$20,000. Technology like linear matrix masking for superb color matching. And Diode Gun Plumbicon advantages like superior sensitivity and resolution and almost non-existent lag, burn in or highlight sticking.

For those of you who favor Saticon® technology, Sharp still offers the best for the least, the XC-800, the first Saticon II camera that lists under \$10,000.

But whether it's Plumbicon or Saticon, Sharp offers you a combination of performance, reliability and economy that no other cameras even come close to.

And if a name is really that important to you, call us anything you like, because when it comes to performance, no one will ever know the difference.

For more information, contact your local dealer, or write: Sharp Electronics Corporation, Professional Products Division, 10 Sharp Plaza, Paramus, New Jersey 07652. (201) 265-5548.



From Sharp... the people who replaced half a million transistors and diodes with one tiny chip.



FROM SHARP MINDS
COME SHARP PRODUCTS

Circle 105 on Reader Service Card

Competition Is Concern in TV Deregulation Proposal

Do current FCC regulations hinder television's ability to compete with newer video technologies? If so, to what degree should regulations be lifted or modified? These questions shape the FCC's recent rulemaking proposing significant deregulation of broadcast TV—similar to the Commission's previous deregulation of radio.

The Commission, which called the rulemaking "a further step toward creating an unregulated, competitive marketplace environment for the development of telecommunications," requested comments on four areas of television regulation: programming policy and guidelines, ascertainment, commercialization, and program logs/reporting requirements. It suggested two options for each area.

The first option for programming

policy, "community issues programming obligations," would give licensees a general obligation to address issues of concern to their communities of license, but would leave the determination of those issues and how to address them entirely up to the broadcaster's discretion. Programming would not be routinely considered at license renewal time or during license application procedures. No guidelines at all would be retained governing amounts of any kind of programming, although a licensee's programming could be renewed in the event of comparative proceedings or petitions to deny.

Alternatively, existing programming policies could be retained, but amended to encourage more programming flexibility.

The ascertainment proposals suggest either complete elimination of all formal ascertainment obligations, or retention of the obligations but without

specification of procedures. The latter option would allow each licensee to determine the appropriate means for ascertainment.

The first commercialization option would eliminate all FCC consideration of commercial time on television stations. The second would retain some guidelines on commercialization, but would permit more flexibility and experimentation by licensees.

The question of program logs, the Commission said, hinges largely on the resolution of the other deregulation questions. Therefore, it asked commenters to suggest record-keeping schemes appropriate to the levels of regulation they propose.

Finally, the FCC invited the public to comment on the benefits of retaining the current regulations in the areas under consideration.

Early reactions to the rulemaking broke along expected lines, with praise

Editel Speeds Telecine Setup with Kodak's Analysis Film

With film-to-tape conversions of feature films and commercials such a big part of its business, Editel, the Hollywood post-production facility, needed a quick and accurate way to set up its Rank Cintel flying spot telecines for correct color balance. A new setup tool from Eastman Kodak,

TAF (telecine analysis film), has been in use at Editel since late last year and has made a big difference, according to sources at the company.

"Having a consistent starting point for color correction saves us several hours a week dubbing feature films and commercials," claims Editel's chief en-

gineer, Dick Caine. "This is a vast improvement over the old Inconel alloy slide, which in any event couldn't be used with the Rank scanner." TAF's principal advantage, according to Caine, is that it enables extremely close density settings. Each frame of the TAF negative film (it is also available in color print versions) contains an eight-step gray scale and a sequence of color blocks approximating color bars in hue and saturation.

Caine states that TAF not only has saved time for Editel, but has also eased some difficult color correction problems. Editel uses TAF for morning checks of all telecines, establishing mean values for color balance, color channel tracking, and shading controls on the variable matrix color correctors and Dubner computers used with the film chains. Color picture monitors are then set up with a Minolta microprocessor-based TV color analyzer.

Clients often aren't aware of TAF, Caine says; they're just pleased with the results. "The people who are really affected are the operators," Caine explains. "Several of our editors have told me it saves them up to 70 percent of the time they'd normally spend setting up color corrections."



Editel's James Gray checks the setup of a Rank Cintel telecine with TAF. Top monitor shows a positive image of the negative TAF.

INTRODUCING SHARP® TRIAX. BECAUSE WE DON'T THINK YOU SHOULD HAVE TO PAY MORE FOR AN IMAGE.



FOR THE XC-800 AND THE XC-900D CAMERAS.

Saticon is a registered trademark of NHK (Japan Broadcast Corp.) Pblumbicon is a registered trademark of N.V. Philips.

If you've decided to invest your money in a quality camera, instead of an image name, you're ready for the Sharp XC-800 with Saticon® II or the XC-900D with Diode Gun Pblumbicon.*

That means you may also be ready for Triax. If you are, Sharp is ready for you. Ready with Triax XC-803TX, the first Triax System that lists under \$10,000. A system whose ultra light-weight cable provides either of these light, rug-

ged cameras with over a mile of mobility. A system that allows you to hook into the existing Triax network of any ballpark, arena, golf course or stadium in the country.

So to paraphrase a famous football coach, when it comes to shooting on the move, Sharp Triax allows you to be agile and mobile at a price that won't make you hostile.

For more information, contact your local dealer, or write: Sharp

Electronics Corporation, Professional Products Division, 10 Sharp Plaza, Paramus, New Jersey 07652. (201) 265-5548.



From Sharp... the people who replaced half a million transistors and diodes with one tiny chip.



**FROM SHARP MINDS
COME SHARP PRODUCTS**

Circle 106 on Reader Service Card

www.americanradiohistory.com

coming from the NAB and criticism from public interest advocates. NAB called the proposals "an obvious and logical next step in easing governmental oversight of broadcasting." On the other side of the fence, Pluria Marshall, president of the National Black Media Coalition, scored the rulemaking as "nonsense," claiming that scarcity was still an operating force in broadcasting. Henry Geller expressed concern that community issue programming be encouraged and recorded.

FCC Adds FM Assignments But Delays Implementation

More than 600 new commercial FM stations could be authorized under a rule modification recently voted by the FCC—but applicants will have to wait until the FCC implements the new rules, which have been put on hold pending "sufficient FCC resources" for the many existing and expected applications.

Essentially, the new rules would ex-

pand the FM service by permitting shorter-range Class A stations on channels now reserved for Class B and Class C stations, which are more powerful. Under current rules, Class A stations have a service radius of 15 miles, with protection from interference to approximately the station's 1 mV/m contour. Class B stations, in more densely populated areas, broadcast to a 40-mile radius with protection to their 0.5 mV/m contours, while Class C stations, in less populated areas, have 57-mile service radii and protection to their 1 mV/m contours.

In adopting the new rules, the Commission rejected a suggestion that the interference protection requirements be made uniform to 1 mV/m for all classes of stations. It created three new classes of stations: B1, to operate in Class B areas with a service range of 45 km (28 miles); Class C1, with a service range of 72 km (45 miles); and Class C2, with a service range of 52 km (32 miles). Classes C1 and C2 would be authorized in Class C areas.

The FCC also tightened its requirements that stations meet minimum facility standards for their station class. All existing stations will have to meet the requirements within three years; failure to do so will result in reclassification. Class C stations must have a minimum antenna height of 300 m (984 feet).

Lastly, the FCC converted its FM rules to the metric system.

Dissenting commissioner James H. Quello issued a statement in which he charged the new standards "would cause degraded service, turmoil and interference for millions of existing listeners, contention and litigation among applicants and further administrative burdens" on the Mass Media Bureau. He predicted serious interference problems resulting from the new stations, and chastised the FCC for not making its technical data available to the public.

THE MERLIN ME-288 DIGITAL IMAGE PROCESSOR IS A NTSC/PAL STANDARDS CONVERTER + TBC + DIGITAL NOISE REDUCER + COLOR CORRECTOR + FRAME SYNCHRONIZER + FIELD & FRAME STORE + HORIZONTAL & VERTICAL IMAGE ENHANCER. . . ALL IN ONE INTEGRATED, LOW-COST UNIT!

Merlin ME-288 Standards Converter

Unique in the field of digital video processing, the ME-288 combines the major image processing and signal correction features plus NTSC to PAL/PAL to NTSC Standards Conversion . . . all for what you would expect to pay for a good TBC/frame synchronizer alone.

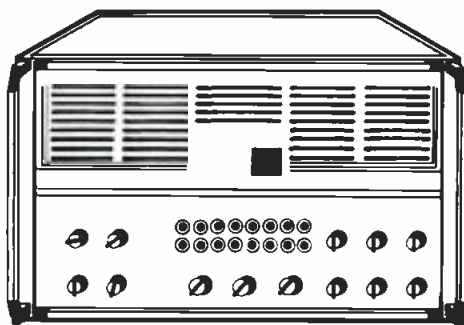

Send for full specifications, today!

MERLIN

1880 Embarcadero, Palo Alto, CA 94303

Call Toll Free — 800-227-1980 (California — Call Collect 415-856-0900)

Merlin Engineering has a full range of products and assemblies for bringing your broadcast VTR up to date, as well as complete engineering facilities for custom applications. Write for your copy of the Merlin catalog.

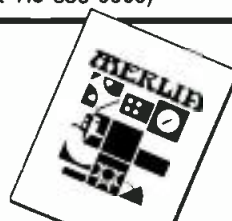

Circle 107 on Reader Service Card

Satellites, Stereo Audio Challenge Cable TV

Cable TV, the television of abundance, is facing a problem in how to channel into the nation's wired homes the abundance of satellite services available today, including the growing number of stereo feeds. (See *BM/E*, July 1983, p. 83 for news feature, "Cable Audio: Can it Deliver?")

While the service providers at the recent National Cable Television Association Convention in Houston hawked their movies, news, and sports packages, cable engineers fretted over the



The M-30 Mobile Production Unit featured at NAB. Equipped with field proven Hitachi HR200E VTR's.

Midwest and Hitachi... a track record for keeping your show on the road.

Whether you're covering a concert or a play-off game, Midwest can get your show on the road fast ... with a fully equipped mobile production unit that meets the tough demands of on-location shoots.

From mini-vans to 45-foot tele-production units, Midwest designs fully integrated mobile systems using only the finest equipment by the finest manufacturers ... like Hitachi. Hitachi's HR200E Type C

One Inch VTR is used in Midwest's Model M-30, and features full studio capabilities plus diagnostics for easy field maintenance. Hitachi builds them for stable performance and durability, and it shows in their proven track record in Midwest mobile units.

For full information on how Midwest and Hitachi can prove their track record for keeping your show on the road, call us toll free today.

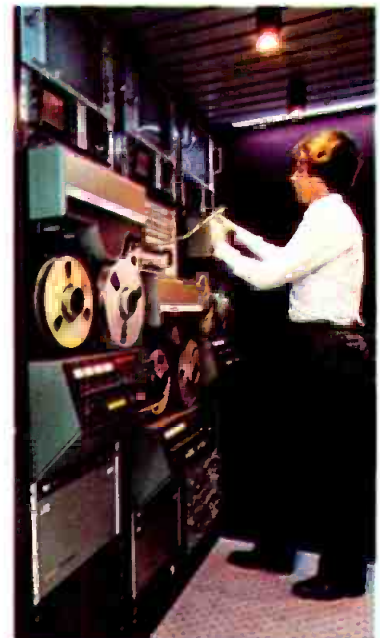

One Sperti Drive
Edgewood, KY 41017

800-543-1584
(In Kentucky 606-331-8990)

Cincinnati, OH
606-331-8990
Columbus, OH
614-476-2800
Dayton, OH
513-298-0421
Cleveland, OH
216-447-9745

Pittsburgh, PA
412-781-7707
Detroit, MI
313-689-9730
Indianapolis, IN
317-251-5750
Louisville, KY
502-491-2888

Lexington, KY
606-277-4994
Bristol, TN
615-968-2289
Nashville, TN
615-331-5791
Charleston, WV
304-722-2921
Virginia Beach, VA
804-464-6256

Washington, DC
301-577-4903
Charlotte, NC
704-399-6336
Atlanta, GA
404-875-3753
Miami, FL
305-592-5355
Tampa, FL
813-885-9308

Circle 108 on Reader Service Card

technical difficulties ahead.

With the proliferation of satellites expected from the FCC's "open skies" policy has come the plan for two-degree spacing for both C band and Ku band birds. In addition, the arrival of the first full-encryption service, the first Ku band pay TV, and the licensing of DBS present an entirely new set of technical problems.

The upshot of all this activity is that cable operators will have to upgrade their present systems. In the opinion of

Norman Weinhouse, Hughes Communications, Inc., "To cope with a C band satellite constellation with two-degree spacing, cable TV receiving antennas will need improved sidelobe performance." In his technical paper delivered at the convention, Weinhouse suggested that the FCC's six-point proposed performance standard will not be adequate for small-aperture antennas, especially with nonhomogeneous space segment. "An offset feed antenna configuration can be implemented at rea-

sonable cost to produce the desired sidelobe performance with an aperture of 4.5 meters diameter or less," he concluded.

Other speakers warned that cable operators, like some of their broadcast brethren who cut corners in setting up earth stations, will have a hard time handling satellite delivery from now on.

Cable stereo is also challenging operators. Stereo presents two problems—cable plant signal degradation and security of premium audio signals. Ironically, while the broadcast industry has been bogged down trying to come up with a standard for over-the-air transmission of stereo TV, the cable industry has been able to deliver this service since 1981. However, when multichannel transmission does begin, it will present yet another problem for cable requiring modification or replacement of headend equipment and descramblers.

Four new stereo TV services were announced at NCTA: Country Music Television Network (CMTV), Black Entertainment Television (BET), Entertainment and Sports Program Network (ESPN), and Hearst/ABC's ARTS. All four will use the Wegener Series 1600 subcarrier transmission system. At the headend, the 1600 demodulates the satellite signal which uses two subcarriers. A monaural (L + R) output feeds a video modulator and left and right outputs feed an FM band modulator. The FM modulator generates a standard FM broadcast format signal at levels suitable for insertion on the cable system in the FM band.

NPR Saved from Drowning by Sudden CPB Bailout

With its last-minute agreement to advance National Public Radio sufficient funds to pay off its current debts, the Corporation for Public Broadcasting has plucked NPR from the troubled financial waters that nearly claimed its life. The price NPR will pay, however, is CPB oversight of its financial operations until the debt is cleared.

The restrictions on CPB's rescue operation came in the form of an amendment to recently passed H.R. 2755, the FCC budget authorization bill. The amendment, offered by House Energy and Commerce Committee chairman John Dingell (D-MI) and Tim Worth (D-CO), chairman of the Telecommunications Subcommittee, bars CPB from giving NPR any federal money until NPR cleans up its financial act. That cleanup is to include adoption of

NEW FROM TFT



STL FOR THE '80's

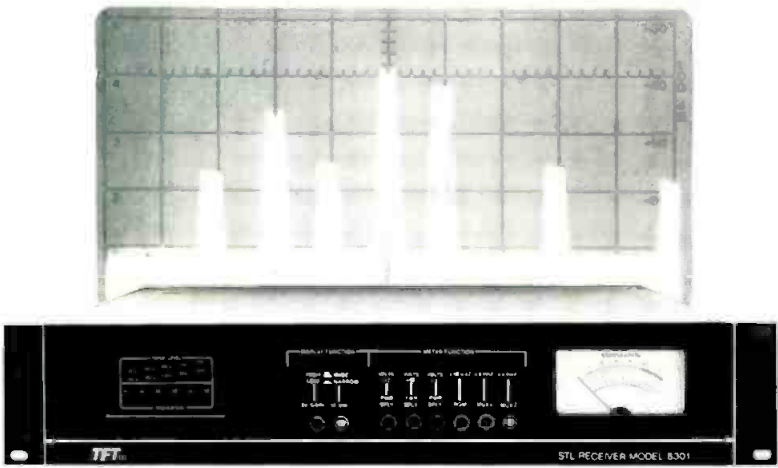

THE 8300

TFT's new Broadcast Quality Aural Studio Transmitter Link and Intercity Relay System brings a new generation of superior STL technology to broadcasting. Specifically designed for the major market's congested RF signal environment, the TFT 8300 provides more features at a lower price than any competitive product.

For further information on the 8300, call TFT—the leader in broadcast product design and manufacture.

Features

- Better than 75dB Stereo SNR
- Over 50dB Stereo Separation
- Saw filter for excellent adjacent protection
- Front Panel Programmable—
 - Receiver Selectivity
 - Receiver Sensitivity
- Full front panel display of all diagnostic parameters, PLUS
 - Simultaneous display of Transmitter Modulation
 - Simultaneous display of Receiver Output
 - Simultaneous display of Receiver RF input level
- AM Stereo Ready



3090 OAKMEAD VILLAGE DR.
SANTA CLARA, CA. 95051
(408) 727-7272 TWX 910-338-0584

Circle 109 on Reader Service Card

anton bauer

Lifesaver™

NEW

Protects your battery investment.



- **Double reliability:**
 1. Logic controlled charge monitor circuitry.
 2. Individual cell sensing system.
- Sophisticated charge routine automatically cycles through 3 different modes... fast charge, equalizing and Lifesaver Maintenance modes.
- Lifesaver circuit eliminates the major cause of premature battery failure and accelerated aging.
- Maintains fully topped battery indefinitely.
- Available in 3 models.



Lifesaver
8 Hour Single

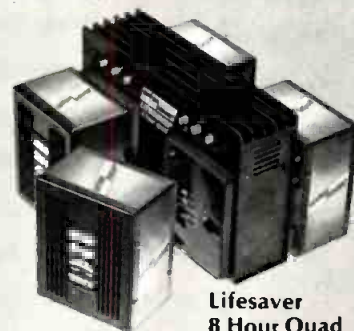

Lifesaver
8 Hour Quad

Call or write for our illustrated Lifesaver brochure and the name of your local dealer.

anton bauer

*The quality standard
of the video industry.*

Anton/Bauer, Inc. □ One Controls Drive, Shelton, CT 06484 □ 203-929-1100

Circle 110 on Reader Service Card

www.americanradiohistory.com

balanced budget in line with reasonably expected revenues and expenditures, along with a financial reporting system that obliges CPB to keep close tabs on NPR's financial activities, with regular reports to Congress. The amendment, which authorized \$70 million in additional funds to CPB for fiscal 1984, expires with the liquidation of the NPR debt.

The CPB loan and fiscal oversight were approved by the overwhelming majority of NPR member stations

shortly after their proposal. Other features of the CPB-NPR agreement call for CPB to forgive a \$600,000 NPR debt and for NPR stations to guarantee the CPB loan with their community service grants, received from CPB. The debt is to be repaid over the next three years. In addition, CPB will begin to channel more programming money away from NPR and toward the member stations, giving the stations more autonomy in their programming choices—with attendant pressure on NPR to

control program costs.

CPB chairman Sharon Rockefeller said she thought NPR would come through the crisis with renewed vigor.

One area in which the shakeup has already been strongly felt is personnel. Board chairman Myron Jones resigned in June under heavy pressure; Donald P. Mullally, GM of WILL-AM/FM/TV, Urbana, succeeded him as interim chairman, to serve until this October. Perhaps Mullally's first official action—it came the same day as his election—was to accept the resignation of the network's chief financial officer and assistant treasurer, Art Roberts. Another board member, Steven K. Meuche, also resigned.

IT SERVES THEM RIGHT!

CREATIVE PRODUCERS DESERVE A VERSATILE SWITCHER

**WIPE BEHIND A CHROMA KEY
WIPE OVER A CHROMA KEY
INDEPENDENTLY POSITIONABLE INSERTS
TWO MIX EFFECTS SYSTEMS
DOWNSTREAM KEYER
MASTER FADE TO BLACK**

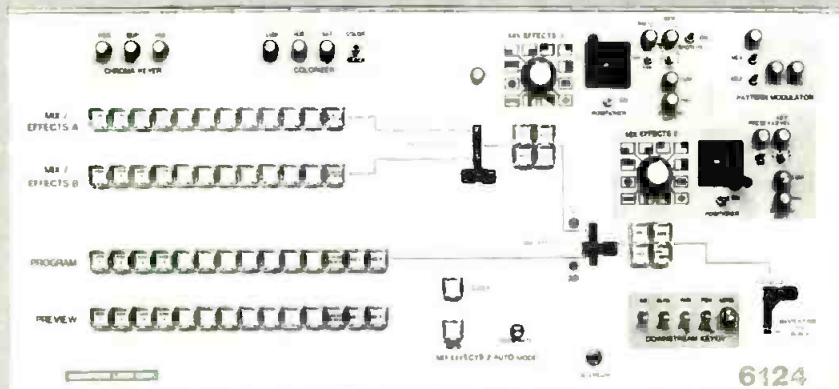

The 6124 production switcher affords a great degree of flexibility. Its two fully independent cascadable mix-effects systems each with a keyer, enable a large number of complex functions to be performed; from simple cuts to the most complicated multiple re-entries.

AUTO DRIVE™ with its S-100 bus computer is a plug compatible option, which may be added to any time, to upgrade the 6124 to a programmable switcher with 225 events. Each event may be set from one frame to 99 minutes. **AUTO DRIVE™** controls all switcher functions simultaneously.

Model 6124

Price N.T.S.C. \$13,700.

P.A.L. \$14,700.

Chroma Keyer Not Available in P.A.L.

CROSSPOINT LATCH CORP.

95 Progress Street • Union, N.J. 07083 • (201) 688-1510 • Telex 181160

After Senate Win, Cable May Face Battle in House

Bolstered by a decisive victory in the Senate, the cable television industry is gearing up for an assault on the House of Representatives, where the going may be more difficult.

The Senate's passage of S. 66, the Cable Telecommunications Act, by an 87 to nine vote, has given cablers the taste of deregulation. The bill, sponsored by Sen. Barry Goldwater (R-AZ), limits the jurisdiction of municipalities over cable franchise holders. Specifically, it restricts local governments from charging franchise fees in excess of five percent of a cable operator's annual revenue, and at the same time bars the cities from imposing rate ceilings. It further strengthens the operators' position by making it illegal for a city arbitrarily to refuse to renew a cable franchise.

Opposition to the bill came from several cities and from AT&T, which claimed that unleashing cable would give system operators an unfair competitive advantage in such services as videotex or home shopping, which could also be offered by telephone companies. An AT&T-backed amendment that would have required the states to regulate such new cable services failed to pass, but the senators did pass another amendment that would lift regulation of AT&T for any service for which it could prove significant cable competition.

Proponents of the cable bill may find more opposition in the House, where local governments and AT&T have more influence. Timothy Wirth (D-CO), chairman of the House Subcommittee on Telecommunications, Consumer Protection and Finance, has stated his support for the bill. At press time, a House version of the bill had not yet been drawn up.

Circle 111 on Reader Service Card

Better audio for 13¢/hr.

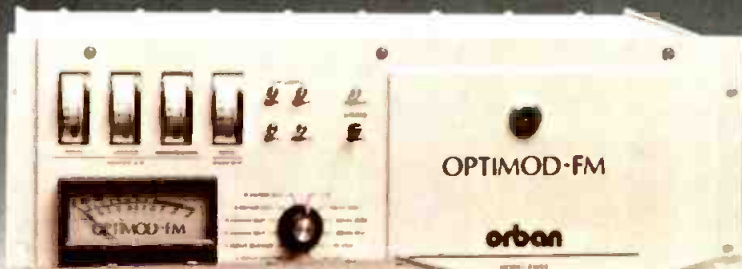

Give or take a few pennies, and using some conservative assumptions (18hr/day, 5 year full depreciation), 13¢/hr is all it costs to replace your current audio processor with an Orban OPTIMOD-AM, -FM, or -TV. And get an *immediate* improvement in on-air audio quality. An improvement that pays off every minute of every hour of every operating day.

OPTIMODS are fully adjustable to program requirements. Their patented technology has literally revolutionized audio processing in the last six years, and yields a cleaner, brighter, louder sound unmatched at any price.

And their superior sound is complemented by Orban quality and service—a well-established, industry-respected commitment that protects your investment.

Money may be tight. But, particularly in trying economic times, the winners are those who compete hardest and deliver the best-sounding product to their audience. OPTIMODs are lethal competitive weapons. And, at 13¢/hr, *very* sound investments.

Can you afford not to go with an OPTIMOD?

For further information, see your local Orban Broadcast Products dealer.

Orban Associates Inc.
645 Bryant Street
San Francisco, CA 94107
Telex: 17-1480

**Toll Free (800) 227-4498,
in California (415) 957-1067.**

orban

ORBAN PROCESSING KEEPS YOU COMPETITIVE

NEWS BRIEFS

FCC Mass Media Bureau chief **Larry Harris** has resigned his Commission post to enter private industry. Harris was scheduled to become president of Metromedia Telecommunications, involved in paging and cellular radio, on July 25 . . . SMPTE has formed a working group for standardization of the **quarter-inch video recording format**, according to SMPTE's Barry C. Detwiler and Roland J. Zavada. The group will initially consider the two quarter-inch systems shown at NAB by Bosch and Hitachi . . . The Interna-

tional Radio and Television Society has elected Viacom's **Ralph M. Baruch** its new president, succeeding Ave Butensky. Edward Bleier of Warner Bros. Television was named first vice president . . . NAB has announced several new appointments. **Belva B. Rissett** has been named vice president, regulatory affairs of the government relations department; **Valerie G. Schulte** has been appointed associate general counsel; and **Richard Green** has been named executive director of the Advanced Television Systems Committee.

In an unexpected move, the U.S. Supreme Court put off a decision on the **legality of home videotaping**, leaving the case to be reargued sometime after the start of the next term, October 3. The ruling was eagerly awaited by all sides after a ruling by the U.S. Court of Appeals for the Ninth Circuit that taping of copyrighted TV shows was a copyright law violation . . . Wold Communications was scheduled to start live, closed-circuit **telecasts of FCC open meetings** June 23. The satellite feeds will be available to TV stations and cable systems over Westar 4, transponder 9x. According to a recent survey by Wold, more than 500 commercial TV stations in the U.S. are capable of receiving satellite program transmission.

The Associated Press broadcast news operation's **move to Washington, DC**, from New York City is well under way and expected to be completed by September, according to the AP. Until then, the national broadcast wires will operate from New York during the daytime and evenings, and from Washington overnight and during morning drive time . . . The Mutual Broadcasting System completed the first phase of its **stereo conversion** a full month ahead of schedule, with 300 stations hooked up. Phase 2 will add more stations.

Taft Broadcasting has exchanged its **WGR-TV**, Buffalo, for General Cinema Corp.'s **WCIX-TV**, Miami. Taft, which will rename its new acquisition **WGRZ-TV**, also gave General Cinema \$65 million cash and a note worth \$5 million . . . Metromedia has sold **KRLD-AM**, Dallas, to the CBS Broadcast Group for \$27 million. The sale includes four radio networks that operate from the station. CBS plans to sell its **WEEL-AM**, Boston, to make room for KRLD . . . Telepictures Corp. has agreed in principle to acquire Midessa Television Co.'s **KMID-TV**, Midland, TX . . . Malrite has purchased **WVNJ-FM**, New York, for a reported \$8 million.

David Brinkley will keynote the thirty-eighth annual **RTNDA convention**, to meet in Los Vegas beginning September 22 . . . **Video Expo New York** will convene at the New York Passenger Ship Terminal September 26 through 30. For more information, contact Ellen Parker, Knowledge Industry Publications, 701 Westchester Ave., White Plains, NY 10604 . . . Ohio State University will sponsor its third annual **conference on videotex** October 3 through 5. For details, contact W. Wayne Talarzyk, OSU, 1775 College Rd., Columbus, OH 43220, (614) 422-2525.

Minolta Broadcast Meters

Remarkable versatility combined with superb accuracy—
Minolta meters conform to CIE Spectral Response Standard.

MINOLTA TV COLOR ANALYZER II

Used for monitor set-up in TV control rooms and for on-line quality control in the manufacture of TV sets.

- Analyzer mode for white balance
- Chroma mode for setting white standard
- Matrix system eliminates cross-over interference
- Four white-memory channels; four CRT memory channels

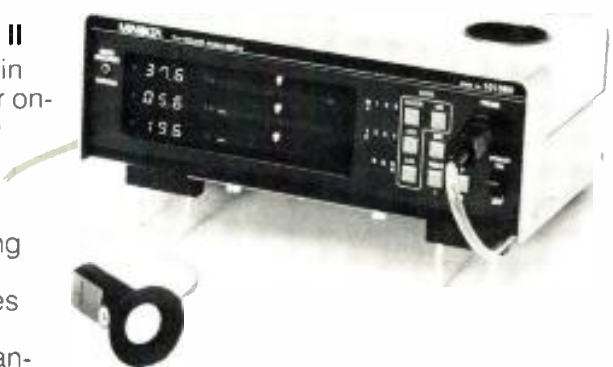

NEW CHROMA METER II INCIDENT



ILLUMINANCE METER



LUMINANCE METER 1°



MINOLTA HAND-HELD INDUSTRIAL METERS ARE:

- Lightweight and compact
- Battery powered for portability
- Rugged—ideal for field use

For more information, write Minolta Corporation,
Industrial Meter Div. 101 Williams Drive Ramsey, NJ 07446
Or call 201-825-4000
© 1983 Minolta Corp.
Product appearance and/or specifications subject to change without notice



Circle 115 on Reader Service Card

Introducing our new klystrons for UHF TV

Utilizing New Compact Magnetics

Type	Power Output
K3270BCD	5 to 15 kW
K3271BCD	15 to 30 kW
K3272BCD	40 to 55 kW

Each tube covers all UHF TV
channels in the USA



- * Beam Control Device for greater energy savings
- * Efficiency 42% min-45% max
- * No Beryllium Oxide Ceramics
- * Water or Vapor Cooled

Another innovative, cost-effective product from EEV, the Company that has continuously advanced high power tube technology for over 40 years.

EEV

Achievement in electron tube technology

EEV, INC.
7 Westchester Plaza, Elmsford, N.Y. 10523.
Tel: 914 592 6050. Telex: 6818096



In Canada: EEV Canada Ltd., 67 Westmore Drive, Rexdale, Ontario M9V 3Y6. Tel: 416 745 9494. Telex: 06 989363 In Europe: EEV, Chelmsford, Essex CM1 2QU, England. Tel: 0245 61777. Telex: 851 99103.

Circle 116 on Reader Service Card

EEV4b

JH-110B-2-HP

Amplitude in dBm

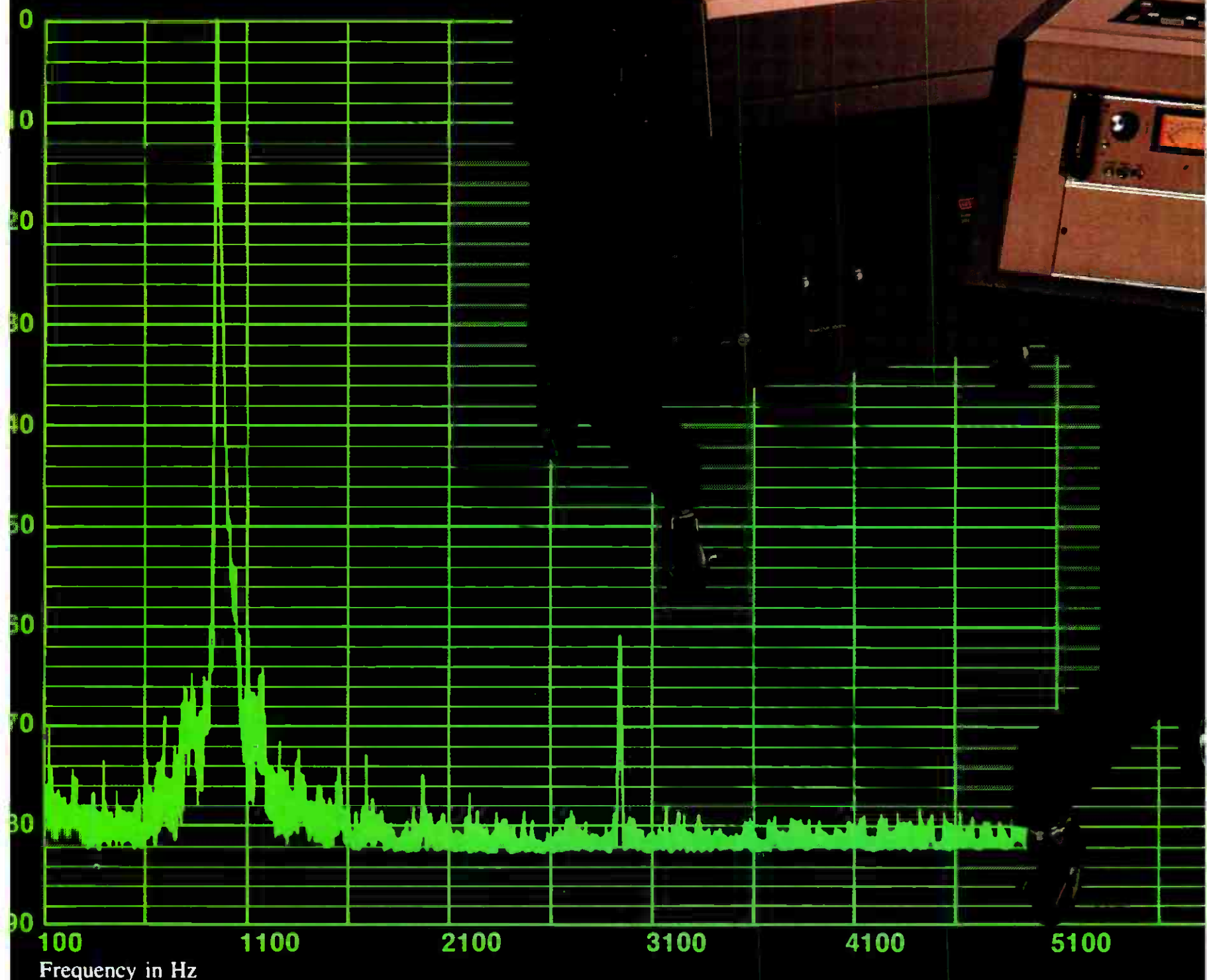

100 1100 2100 3100 4100 5100
Frequency in Hz

DISTORTION/PURITY OF SIGNAL

DOES MCI REALLY OUTPERFORM THE REST?



In a world filled with claims and counter claims for high performance audio products, sometimes it's hard to separate opinion from fact. That's why MCI has provided complete graphic proof of all important tape recorder/reproducer performance characteristics. Now available in a handy Engineering Notebook, these curves and their accompanying methodology form the standard by which all other tape recorders must be judged.

If performance matters in your broadcast or teleproduction application, don't be fooled by "simple specmanship." And if you want to decide for yourself how the JH-110 Series measures up to comparable units, just ask Sony Broadcast to arrange for a demonstration.

Does MCI really outperform the rest? We'll let you decide. For your free copy of the Engineering Notebook and more information about our demonstrator program, call Tony Dean, Eastern Regional Sales Manager, Audio Products, (305) 771-3997, or Holmes Ives, Western Regional Sales Manager, Audio Products, (213) 841-8711.

SONY
Broadcast

JH-110B-2-VP

© 1983 Sony Corp. of America. Sony is a registered trademark of the Sony Corp.

Circle 117 on Reader Service Card



Get it out of your system.

Television is an electronic medium. Yet TV graphics still involve messy paints, glue, air brushes, razors, and other paraphernalia.

MCI/Quantel's Paint Box can put your TV graphics into the electronic medium.

So you can get all the messy paraphernalia out of your system. Digitally.

The Paint Box lets you do a lot more than you can do with traditional art materials. A lot faster. And with typical Quantel picture quality.

It gives you over 16 million colors. If that's not enough, you can mix your own, just like you'd do with paints.

It's incredibly versatile. You can produce the look of oils, watercolors, chalk, pencil. You can make stencils. Air brush. Cut and paste. Even animate.

You can grab TV frames off the air, resize them, retouch them, mix them with graphics.

You can set type from a large variety of the highest quality fonts.

And you can interface the Paint Box to Quantel's DLS 6000 Library System for a totally digital still-picture system. It's awesome.

Call your local MCI/Quantel office. They'll be glad to show you a demonstration tape. Or get in touch with us directly at 415/856-6226. Micro Consultants, Inc., P.O. Box 50810, Palo Alto, California 94303.

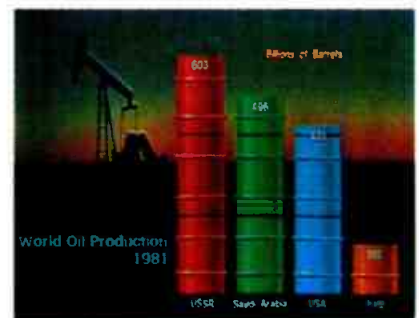

Graphics like this are easy on the Paint Box.



MCI/QUANTEL
The digital video people.

Circle 118 on Reader Service Card

BM/E

BROADCAST MANAGEMENT/ENGINEERING

THE 1983 BUYER'S GUIDE SOURCE

HOW TO USE IT:

INSTANT SOURCE LOCATOR p. 27

To find suppliers of the product or service you want, first turn to the **Instant Source Locator**—an index of over 200 product types arranged in seven major categories: Audio; Video, Imaging; Lighting, Power, Support, Set Design, Etc.; RF, Transmitting/Receiving Equipment, Antennas, Towers; Test & Measurement, Logging, Timing; Components, Hardware; and Services. Within each main product category (they're arranged logically), you'll find manufacturers listed alphabetically. The check (✓) indicates that the listing is verified—that the product or service is currently available. The numbers after the manufacturer's name refer to the specific types of product offered.

LISTING OF MANUFACTURERS p. 59

Once you've located the names of the manufacturers in the ISL, you can learn more details from the **Alphabet-**

ical Listing of Manufacturers. Address and phone number are followed by a complete listing of the manufacturer's product line, plus, in some cases, the manufacturer's field offices. These listings are also verified.

REPS/DISTRIBUTORS SECTION p. 151

Advertisers' reps and distributors throughout the country are listed in the **Reps/Distributors Section**, arranged alphabetically within each state.

READER SERVICE CARD p. 177

To get even more information about the products and services which are advertised in **THE SOURCE**, use the **Reader Service Card** found on page 177. You can circle the Reader Service numbers for information on as many manufacturers as you like. And don't forget—the card is good for an entire year!

The new Philips LDK 6

**The first "total"
automatic camera.**

Only the LDK6 provides 100% automatic control for all primary and secondary setup adjustments... plus it has multiple diagnostic systems and many other automatic and operating features.

The LDK6's advanced design provides unprecedented reliability and flexibility. It launches a new era for broadcast and production.

If you are interested in the most advanced studio/field camera available today, and the best investment for the '80s... put yourself behind the LDK6.

Call or write for details.
Philips Television Systems, Inc.
900 Corporate Drive
Mahwah, New Jersey 07430
201-529-1550

Circle 119 on Reader Service Card



PHILIPS



INSTANT SOURCE LOCATOR ✓ MEANS IT'S VERIFIED

AUDIO

Consoles

TYPES:

- (1) Mic mixers (1 output)
- (2) Portable consoles
- (3) Studio consoles (3+ outputs)—mono
- (4) Studio consoles—stereo
- (5) Automated Consoles
- (6) TV audio consoles

SUPPLIERS:

ADM ✓ (3,4,6); Amek ✓ (3,4); Arrakis ✓ (1-4,6); Atlantic Research ✓ (2-6); Audioarts ✓ (3,4); Audio Developments ✓ (1-4,6); Audio Metrics ✓ (3,4); Audio Processing ✓ (2-5); Audio Technica ✓ (6); Audio Techniques (2-5); Audisar ✓ (1,2); Audionics ✓ (3-6); Autogram ✓ (3-6); Bayly ✓ (2); Broadcast Audio ✓ (3,4,6); Broadcast Electronics ✓ (3,4); Broadcast Technology ✓ (1-4,6); BSM (2,3); Cetec Broadcast ✓ (2,3,4,6); Clyde ✓ (2,3,4); Coherent ✓ (1,2); Comprehensive Video ✓ (1); Comrex ✓ (2); Connectronics ✓ (2); Continental Electronics ✓ (4); Crosspoint Latch ✓ (5); Datatronix ✓ (2-6); Dyma ✓ (2,3,4,6); Edcor (1); Eela ✓ (1-4,6); Elcom Bauer ✓ (3); Electro-Voice ✓ (1,2,4); Farrtronics ✓ (2); Finnitek (1-4,6); Fostex (1,2,6); Gotham Audio ✓ (2,3,4,6); Graham-Patten ✓ (4); Gregg ✓ (3,4); Hallikainen ✓ (6); Harris Broadcast ✓ (1-5); Harrison ✓ (2-6); Howe ✓ (1,4,6); Image Devices ✓ (1); Industrial Research (1); Industrial Sciences ✓ (3); Integrated Sound ✓ (4); Interface Electronics ✓ (2); Logitek ✓ (2-6); Long; LPB ✓ (1,3,4,6); LTM ✓ (1); McCurdy ✓ (1,3,4,6); MCI/Sony ✓ (2-6); McMartin ✓ (1-4,6); Micro-Trak ✓ (1-4,6); NEI ✓ (1-4); Neve (1-6); Nikko ✓ (3,4); Opamp ✓ (1-4,6); Pacific Recorders ✓ (4); Quad-Eight ✓ (3-6); Quantum ✓ (1-4,6); Ramko ✓ (1-4,6); Ramsa ✓ (2,3,4); Richmond Sound ✓ (1-4,6); RTS ✓ (1,2); Satt ✓ (2); Seem ✓ (2); Sescor ✓ (1); Shure ✓ (1,2); Sony ✓ (2); Soundcraft ✓ (2,4,5); Sound Workshop ✓ (6); Spectra Sonics (1-4,6); Sphere ✓ (2-6); Studer Revox ✓ (1-4,6); Studiomasster (1-4,6); TEAC ✓ (3); Telfax (1); Transist-O-Sound (1); Trident ✓ (2-6); Tweed ✓ (1-6); Ultra Audio ✓ (1,2,3,6); UMC ✓ (2,3,4); United Recording ✓ (2,4); Ward-Beck ✓ (2,3,4,6); Yamaha ✓ (1,2)

Cart Players/Recorders

TYPES:

- (1) Single deck
- (2) Dual/triple deck
- (3) Multideck
- (4) Time delay
- (5) Phase control matrixing

SUPPLIERS:

AKG ✓ (4); Amilon (1-4); Audi-Cord ✓ (1,2,4); Bell Audio (1); Broadcast Electronics ✓ (1-4); Deltamod ✓ (5); Elcom Bauer ✓ (1); IGM ✓ (3); International Tapetronics ✓ (1,2,3); MacKenzie (1,2,3); Pacific Recorders ✓ (1,5); Ramko ✓ (1,2,5); Sono-Mag ✓ (1,3,4); Straight Wire ✓ (5); Telectro ✓ (1,2); Telex ✓ (1); UMC ✓ (1,2,3,5); Yamaha ✓ (4)

Cassette Players/Recorders

SUPPLIERS:

Audiotronics ✓; Eumig ✓; Fostex ✓; Image Devices ✓; Leader Broadcast ✓; Nikko ✓; Odetics; Pentagon ✓; Ramko ✓;

Sansui ✓; HH Scott; Scribe ✓; Sharp ✓; Studer Revox ✓; Studiomasster; Superscope ✓; Tandberg ✓; TEAC ✓; Technics ✓; Telectro ✓; Tiffen ✓

Open-Reel Decks

TYPES:

- (1) Portable ATRs
- (2) 2,4-track studio ATRs
- (3) Multitrack (8+) ATRs
- (4) Time delay decks

SUPPLIERS:

Ampex ✓ (1,2,3); Cavox ✓ (1,2); Fostex ✓ (2,3,4); Gotham Audio ✓ (1,2,3); International Tapetronics ✓ (2); Leader Broadcast ✓ (1-4); Lyrec ✓ (2,3); MCI/Sony ✓ (2,3); Nagra ✓ (1,2); Otari ✓ (1,2,3); Ramko ✓ (2); Soundcraft ✓ (3); Stephens ✓ (1,2,3); Studer Revox ✓ (1,2,3); Tandberg ✓ (1,2); TEAC ✓ (2); Technics ✓ (2); Telex ✓ (2); United Research ✓ (2); Zellan ✓ (1,2,3)

Digital Audio Recorders

SUPPLIERS:

Audiotronics ✓; 3M ✓; Mitsubishi ✓; Odetics ✓; Sansui ✓; Sony ✓

Tape Duplicators

SUPPLIERS:

Accurate Sound ✓; Audio/Tek; Cetec Gauss ✓; Dynacom; Electro Sound; Garner ✓; Nagra ✓; Odetics ✓; Otari ✓; Pentagon ✓; RKO Tape; Sharp ✓; Telectro ✓; Telex ✓

Sprocketed Magnetic Film Transports, Dubbers

SUPPLIERS:

Leader Broadcast ✓; Magnasync/Moviola ✓; Magna-Tech ✓; Multi-Track ✓; Rangertone ✓; Rank Precision ✓; Wide Range ✓

Heads, Accessories

TYPES:

- (1) Replacement heads
- (2) Rebuilt heads
- (3) Head cleaners, degaussers
- (4) Alignment, tension gauges

SUPPLIERS:

Ampex ✓ (1,2); Allsop ✓ (1,2); R.B. Annis ✓ (3); Audio Techniques (1,3,4); Broadcast Electronics ✓ (8,9); Electro Sound (1,4); Fidelipac ✓ (4); International ElectroMagnetics (1,2); JRF ✓ (1,2); Lauderdale (4); Leader Broadcast ✓ (1,2,3,4); Marathon (3); Memorex ✓ (3); Microtran (3); Minneapolis Magnetics (1); Multi-Track ✓ (1,4); Nagra ✓ (1,3); Nortronics ✓ (1,3,4); Pentagon ✓ (4); Ramko ✓ (1); Rangertone ✓ (1); RE:dB ✓ (1,2); Saki ✓ (1); Taber ✓ (1); TEAC ✓ (3); Tentel ✓ (4); Texwipe ✓ (3); UMC ✓ (1,4); United Research ✓ (1); Wide Range ✓ (3)



Audio Tape, Accessories

TYPES:

- 1) Open-reel tape
- 2) Carts
- 3) Cassettes
- 4) Test tapes
- 5) Sprocketed magnetic film
- 6) Empty reels, carts
- 7) Leader tape
- 8) Tape loaders
- 9) Tape timers, rewinders
- 10) Bulk erasers
- 11) Conveyor erasers
- 12) Tape cleaners, evaluators
- 13) Other

SUPPLIERS:

Agfa-Gevaert ✓ (1,3); Ampex ✓ (1-4,6,7); R.B. Annis ✓ (10); Aristocart ✓ (2,4,6); Audico ✓ (8,9); BASF ✓ (1,3,4); Broadcast Cart ✓ (2,6); Calzone ✓ (6); Capitol ✓ (2); Deltamod ✓ (4); Dictaphone ✓ (1,6); Electro Sound (3,4,8); Fidelipac ✓ (2,4,6,10,12); Garner ✓ (10); Gruver (3); Inovonics ✓ (13); International Tapetronics ✓ (2); Koss ✓ (12); Kozin (1,3,6,7); Lauderdale (10,12); 3M ✓ (1,2,3,5-8); Magnasync/Moviola ✓ (10); Magnetic Reference (4); Marathon ✓ (2,4,12,13); Memorex ✓ (2,3); Microtran (10); Nagra ✓ (4); Neumade ✓ (2,5,6,8,9); Nortronics ✓ (10,12); Odetics ✓ (3,10); PDM (3); Peak Audio ✓ (9); Pentagon ✓ (9); Plastic Reel ✓ (6); Procart ✓ (2); Ramko ✓ (2,8); Recortec ✓ (3,12); RKO Tape (1,3); Smith-Victor ✓ (3); Sonar ✓ (10); Standard Tape (4); Taber ✓ (10); Tapex (2,3,4); TDK ✓ (1,3,4); Telex ✓ (4); UMC ✓ (10, splice finder); Wallach ✓ (2,6); Wide Range ✓ (10)



Editing Equipment, Accessories

TYPES:

- 1) Splicing blocks, tape
- 2) Electronic editors
- 3) Digital audio editors
- 4) SMPTE time code synchronizers
- 5) Other

SUPPLIERS:

Adams-Smith ✓ (4); Audio Kinetics ✓ (2,4); Automated Studio Technologies ✓ (2); Bosch ✓ (2); BTX ✓ (2,4); Control Video ✓ (2,4); Datum ✓ (4,5); EECO ✓ (2,4); Electro Sound (1); F&B/Ceco (1); Fidelipac ✓ (1); Harris Broadcast ✓ (2); Interactive ✓ (2,4); Jatex ✓ (2); Kalart Victor ✓ (1,5); Lauderdale (1); Leader Broadcast ✓ (4); Lyrec ✓ (2); Marathon ✓ (1); MCI/Sony ✓ (4); Multi-Track ✓ (4); Plastic Reel ✓ (1); Quad-Eight ✓ (3); Redding Radio (5); Stephens ✓ (1,4); Studer Revox ✓ (4); United Media ✓ (2,4, ADR controller); Videomedia ✓ (2); Xedit (1)

Disc Playing Equipment

TYPES:

- 1) Turntables
- 2) Pickup arms
- 3) Phono cartridges
- 4) Phono preamps
- 5) Complete disc playing consoles
- 6) Record cleaning, care

SUPPLIERS:

Advancing Technology ✓ (4); AKG ✓ (3); Allsop ✓ (6); Astatic (2,3); Audio Metrics ✓ (4); Audionics ✓ (4); Audio Technologies (4); Audio-Technica ✓ (2,3,6); Audisar ✓ (4); Broadcast Electronics ✓ (1,2,4); Cetec Broadcast ✓ (1,2); Fidelipac ✓ (2,3); Gotham Audio ✓ (1,2,3,5); Gregg ✓ (4); Integrated Sound ✓ (1,5); Lauderdale (6); Logitek ✓ (4); LPB ✓ (1,2); McCurdy ✓ (1); Micro-Trak ✓ (1,2,4,5); Modular Audio ✓ (4); Keith Monks ✓ (6); Nikko ✓ (1); Opamp ✓ (4); Radio Systems ✓ (4); Ramko ✓

(1,4); Richmond Sound ✓ (4); RTS ✓ (4); Sharp ✓; Shure ✓ (2,3); Stanton ✓ (3,4,6); Straight Wire ✓ (4); Studer Revox ✓ (1); Technics ✓ (1)

Program, Business Automation

TYPES:

- 1) Relay sequencers
- 2) Time insertion sequencers
- 3) Computer controllers
- 4) Complete program automation systems
- 5) Auto time, weather announce
- 6) Radio business automation hardware
- 7) Radio newsroom computers

SUPPLIERS:

Paul Adams ✓ (3,4,6); Anacomp ✓ (4,6); Applelog ✓ (6); Automated Broadcast (4,6); Automated Business Concepts (6); Basys ✓ (7); Briner-Chase ✓ (6); Broadcast Electronics ✓ (4); Cado (6); Cavox ✓ (1,2,4,5); Cetec Broadcast ✓ (2-6); Channelmatic (1,2,3); Clarcomputer ✓ (4); Columbine ✓ (4); Computer Business (6); Computer Concepts (4,6,7); Control Technology (1-5); Cross (6); Custom Business ✓ (6); Data Comm. ✓ (6); Di-Tech ✓ (3); Generic (6); Groton (4,6); Harris Broadcast ✓ (2,4-7); Hewlett-Packard ✓ (6); IGM ✓ (4); Interface Data ✓ (2,3,4,6,7); Jefferson Data ✓ (6,7); Jenel (4); Kaman ✓ (4,6,7); Libra (6); Magnicom ✓; The Management ✓ (6); Marketron (6); Microprobe (2,3,6); Quanta ✓ (7); Radiocom ✓ (6); Register Data ✓ (6); Sharepoint (3); Sono-Mag ✓ (3,4); Southwestern ✓ (6); Spectrum ✓ (6); UMC ✓ (4)

Audio Processing, Effects

TYPES:

- 1) ALC, AGC amplifiers
- 2) AM compressor/limiters
- 3) FM compressor/limiters
- 4) Parametric equalizers
- 5) Graphic equalizers
- 6) Digital special effects
- 7) Digital delay, reverb
- 8) Analog special effects, reverb
- 9) Mechanical reverb
- 10) Audio/video sync delay
- 11) Time compression/expansion
- 12) Noise reduction
- 13) Music synthesizers
- 14) Other (de-essers, etc.)

SUPPLIERS:

ADM ✓ (2,3,4); Advanced Music ✓ (6,7,8,10,11); Advancing Technology ✓ (1-4); AKG ✓ (7,8); Altec Lansing ✓ (5); Aphex ✓ (3,4,14); Ashly (3,4,12); Atlantic Research ✓ (2-5); Audioarts ✓ (3,4,5); Audio + Design ✓ (1-5,8,12,14); Audionics ✓ (14); Audio Processing ✓ (4,5); Audio Technologies (1-4,12); Audio Technology (12); Audisar ✓ (4,5); Audionics ✓ (4); Broadcast Electronics ✓ (2,3); Broadcast Technology ✓ (5,14); Circuit Research ✓ (2); Comex ✓ (7); Comrex ✓ (1); Connectronics ✓ (9,14); CRL ✓ (1,2,3); Datatronix ✓ (2-5); dbx ✓ (1-4,6,12); Delta ✓ (1,2); Deltamod ✓ (12); Dolby ✓ (12); Dyma ✓ (4,5,8); Elcom Bauer ✓ (1,2,3); Electro-Voice ✓ (5,8,9); ESC (14); Eventide ✓ (1,6,7,11,14); EXR (14); Foxtex ✓ (4,5,8,12); Frequency Devices ✓ (4,5,12); Gotham Audio ✓ (2,3,7,8,9,12); Gregg ✓ (1,2,3,14); Harris Broadcast ✓ (1,2,3); Harrison ✓ (5); Howe ✓ (14); Industrial Research (6,10); Inovonics ✓ (1,2,3,12); Integrated Sound ✓ (5,11); International ElectroMagnetics (5); Ivie ✓ (5,7); Kahn ✓ (2); Klark-Teknik ✓ (5,6,8,9); Koss ✓ (7); Lear Siegler (2,3,5); Lexicon ✓ (6,7,10,11); Logitek ✓ (1); LPB ✓ (2,3); Marcom ✓ (2,3); Marti ✓ (1,2,3); McCurdy ✓ (2,4); MCI/Quantel ✓ (10); McMartin ✓ (1,2,3,5); MicMix ✓ (9,12); Modular Audio ✓ (2,3,5); Moog ✓ (13); Moseley ✓ (1,2,3); MXR ✓ (3,5-8,14); NEI ✓ (4,5,8,9); Neve ✓ (2,3); Nikko ✓ (4,5); Opamp ✓ (1,5,9,13); Orban ✓ (2-5,14); Processing Plus ✓ (1,2,3); Protech ✓ (1,2); Quad-Eight ✓ (2,4,5,7,8,9); Ramko ✓ (2); Richmond Sound ✓ (1,4,5); Sansui ✓ (5); Ken Schaffer ✓ (6,7,11); Sescor ✓ (1); Spectra Sonics (1,2,3,5,8); Straight Wire ✓ (12); Superex (4); Symetrix ✓ (2,3,4); TEAC ✓ (5); Thomson-CSF ✓ (1,2,3, presence EQ); Trident ✓ (4,6,7,8,11); Tweed ✓ (2-5,12); United Recordings ✓ (1-5,12); Ursa Major ✓ (6,7); Valley People (1-4,12); Ward Beck ✓ (4); White ✓ (5); Yamaha ✓ (5,8)

Microtime synchronizers.
The features you want.
The prices you can afford.

S-230. A TBC that synchronizes. A synchronizer that time base corrects. In a 3½" high, 27 lb. package. The S-230 synchronizes and time base corrects external signals such as network, ENG, microwave, satellite and remote studio feeds. And because it contains an infinite window TBC, it works with all 1/2" and 3/4" heterodyne VTR formats, with or without capstan servos.

The Auto Mode switching feature samples incoming signals and automatically

selects the correct mode, TBC or synchronizer. The 8 bit, 4X subcarrier digital design and microprocessor-directed memory mean high reliability and transparent performance. Full frame memory allows manual selection of Field 1, Field 2 or Full Frame Freeze. Operator-selectable automatic freeze detectors permit controllable response to fading signals. All for only \$13,450.



S-130. The most full frame synchronizer for the money. Like the S-230, it features a

microprocessor subroutine that provides ease of maintenance and confidence testing. The S-130 synchronizes external signals such as network, ENG, microwave, satellite and remote studio feeds, and is ideal for the new Harmonically Related Carrier (HRC) designs in CATV applications. Only \$10,900.



MICROTIME

A Subsidiary of ANDERSEN GROUP

1280 Blue Hills Ave., Bloomfield,
CT 06002. (203) 242-4242.
TWX 710-425-1165.

Circle 120 on Reader Service Card

Savings in synch.





Audio Monitors

TYPES:

- (1) Speakers
- (2) Headphones

SUPPLIERS:

Acoustic Research (1); AKG (2); Altec Lansing (1); Atlas Sound (1); Audio Techniques (1,2); Audio-Technica (2); Audisar (1); Auernheimer (1); Auratone (1); Beyer (2); Cetec Gauss (2); David Clark (2); Clear-Com (2); Dorrough (2,3); Electro-Voice (1); Fostex (1); Gotham Audio (1); Integrated Sound (1); Koss (1,2); Lansing (1); Logitek (1); McKay Dymek (1); Micro-Trak (1); Ramko (1); Sennheiser (2); Setcom (2); Sharp (1); Shure (2); Sony (2); Spectra Sonics (1); Stanton (2); Studer Revox (1); Superex (2); Telectro (1); TEA (2); Telex (2); United Recording (1); V.A.M.P. (1); Vidair (2); Westlake (1); Yamaha (1)

Intercom Systems

TYPES:

- (1) RF
- (2) Hardwired

SUPPLIERS:

Cetec Vega (1); David Clark (2); Clear-Com (2); Coherent Comm. (1); Comrex (1); Edcor (1); Fartronics (2); Fisher Berkeley (2); HME (1,2); Lear Siegler (2); Long; Marshall Elect. (6,7,8,10,11); McCurdy (2); McMartin (2); Minicom (2); Motorola (1); Nady (1); Protech (2); R-Columbia (1,2); ROH (2); RTS (2); Ken Schaffer (1); Setcom (2); Swintek (1); Telex (2); Theatre Techniques (2); TVI (2); Tweed (2); Vidair (1); Video Aids (2)

Microphones

TYPES:

- 1 Dynamic
- 2 Electret/condenser
- 3 Ribbon
- 4 PZM
- 5 RF
- 6 Shotgun
- 7 Lavalier
- 8 Modular, capsule mics
- 9 Mic stands, booms, dollies

SUPPLIERS:

AKG (1,2,6-9); Altec Lansing (1,2,7,9); Astatic (1,2,7,9); Atlas Sound (9); Audio-Technica (1,2,6,7); Beyer (1,2,3,5-9); Bruel & Kjaer (2); Calrec (2,8); Cetec Vega (5); Coherent (2,5,7); Comrex (5); Countryman (2,7,8); Dyma (1); Edcor (1,5,7); Electro-Voice (1,2,6-9); F&B/Ceco (9); Fidelipac (1,2,6,7,9); Alan Gordon (5); Gotham Audio (2,6,9); HME (5); Image Devices (2); Integrated Sound (1,2,6); Lauderdale (9); Leader Broadcast (1,2,3,5-9); LTM (9); Marti (1); Matthews (9); Micron (2,5,7); Keith Monks (9); Nady (5); Odetics (1,2,9); R-Columbia (1,2); RMS (1); Ken Schaffer (5); Sennheiser (1,2,5-9); Shure (1,2,3,7,8,9); Sony (1,2,5-8); Superscope (2); Swintek (5,7); TEA (1,2); TEAC (1,2); Telex (1,2,7); Vidair (1,2)

Telco Interface Equipment

SUPPLIERS:

Audio Acc. (2); Audisar (2); Broadcast Electronics (2); Comrex (2); Gregg (2); Howe (2); Monroe (2); Old Dominion (2); Redding Radio; RTS (2); Studer Revox (2); Symetrix (2); Telfax (2)

Audio Amplifiers

TYPES:

- (1) Preamps
- (2) Line amps
- (3) Monitor, power amps

- (4) Audio DAs
- (5) Amp power supplies

SUPPLIERS:

ADM (1,4); Allied Bdcst. (1,4); Altec Lansing (1,2,3); Arrakis (1,3,4,5); Atlantic Research (1-4); Audio Metrics (4); Audio Technologies (1-5); Audionics (3); Audio + Design (1,4); Audisar (1-4); Auditronics (1,2,4); AVL Digital (3,4); Bayly (1-4); Bell Audio (1,2,4); BGW (3); Bonnevill (2,4); Bosch (1,3,4); Broadcast Audio (3,4); Broadcast Electronics (1-4); Broadcast Technology (1-5); Bryston (1,3); BSM (4); Calrec (1); Central Dynamics (1-5); Channematic (4); CMD (4); Commerce Airborne (4); CRL (3); Datatek (1-4); Datatronix (1-5); Datum (2); Di-Tech (4); Dyma (1,2,3); Dynair (4); Edcor (1,2,3); Electro-Voice (2,3); Eumig (1,2,3,5); Frequency Devices (5); Graham-Patten (4); Heath (1,3); Hedco (2,4); Hewlett-Packard (1,2); IGM (4); Integrated Sound (3); International Nuclear (1-5); ITI (1,2,3,5); Ivie (1,3); JV Electronics (4); Kahn (2); Lansing (2,3); Lauderdale (1,4); Lear Siegler (1,2,3); Logitek (1,3,4); Marti (2,3); McCurdy (2-5); McMartin (1,2,3); Micro-Trak (1-4); Milan (4); Modular Audio (1-5); Multidyne (1,2,4); MXR (1); Neve (2,4); Nikko (1,3); Opamp (1-5); Pacific Recorders (4); Processing Plus (3); Protech (1-5); Quad-Eight (1,2); Radio Systems (3); Ramko (1-5); Ramsa (3); Rangertone (1,2); Richmond Sound (1,2,4,5); ROH (1-4); RTS (1-5); Russco (1,3,4); Sescom (1,2,3,5); Sharp (1,2,3); Shintron (4); Shure (1,2,3); Sigma (4); Spectra Sonics (1-5); Sphere (1,2,3); Stanton (1); Straight Wire (1-5); Studer Revox (3); Studiomaster (3); Symetrix (3); Taber (1,2,6); Tandberg (1,3); TEAC (1,5); Telemet (3,4); TEA (4); Telfax (2); Thomson-CSF (4); TM Systems (2,5); Tweed (1-5); Ultra Audio (3,4); United Recording (1,3); Valley People (1,2); Vamco (4); Videotek (4); Vital (4); Ward-Beck (1-5); World Video (3); Yamaha (3)



Audio Controls

TYPES:

- (1) Rotary attenuators
- (2) Slide attenuators

SUPPLIERS:

Atlantic Research (2); CMD (2); Duncan Electronics (2); Opamp (1,2); Penny & Giles (1,2); Protech (2); ROH (2); Sescom (1,2); Shalco (1,2); Spectra Sonics (1,2); Tech Labs (1,2); United Recording (2); Vidair (1); Waters (1,2)

Audio Level Indicators

TYPES:

- (1) VU
- (2) PPM
- (3) Video monitor display
- (4) LED or other

SUPPLIERS:

Advancing Technology (1,2); Arrakis (1,4); Audio Technologies (1); Audio Technology (1,2,4); Audio Processing (1,2); Audio + Design (1,2,4); Auditronics (2); Broadcast Technology (1,2,4); Dorrough (4); ESE (4); Gotham Audio (2,3,4); Harrison (1,2,3); Inovonics (2); Leader Bdcst. (1,2); Logitek (1,2,4); McCurdy (2); McMartin (1); Opamp (1); Quad Eight (4); Ramko (4); Rangertone (1); Real World (1,2); Scott (1,2); Spectra Sonics (1); Telemet (1); TM Systems (1); Valley People; Ward-Beck (1); Weston (1-4);

Other Audio, Radio Equipment

TYPES:

- (1) Audio patch panels
- (2) Soundproofing material
- (3) EBS two-tone systems
- (4) Other

There's a Microtime Time Base Corrector for every application. And budget.

T-100. One of the lowest priced digital TBCs in the world. But you'd never know it when you see what it does. Designed with many of the features that made our T-120 the industry leader, the T-100 offers unparalleled performance for a wide range of broadcast, industrial, cable and low power television applications. The most TBC for the money. **\$6,950.**

T-120. The T-120 does everything but cost a lot. Engineered to bring out the best in non-segmented 1/2" and 3/4" VTRs. Designed and built to outperform anything in its class. The price: **\$8,450.**

with a SONY* BVU-820 U-MATIC* VTR. Connect two T-120Ds to our optional E-120 effects processor, and the result is an inexpensive effects system that provides A/B roll editing, digital effects and DYNAMIC TRACKING.* Only **\$9,950.**

T-120D. A dynamic breakthrough in TBC technology. The T-120D features two major improvements: DYNAMIC TRACKING (DT)* and digital effects capabilities. DT operation allows for "on air" slow motion and freeze frame when used

DYNAMIC TRACKING. SONY and U-MATIC are registered trademarks of Sony Corp.

MICROTIME

A Subsidiary of ANDERSEN GROUP

1280 Blue Hills Ave., Bloomfield, CT 06002. (203) 242-4242. TWX 710-425-1165.

Circle 121 on Reader Service Card

All in good time.



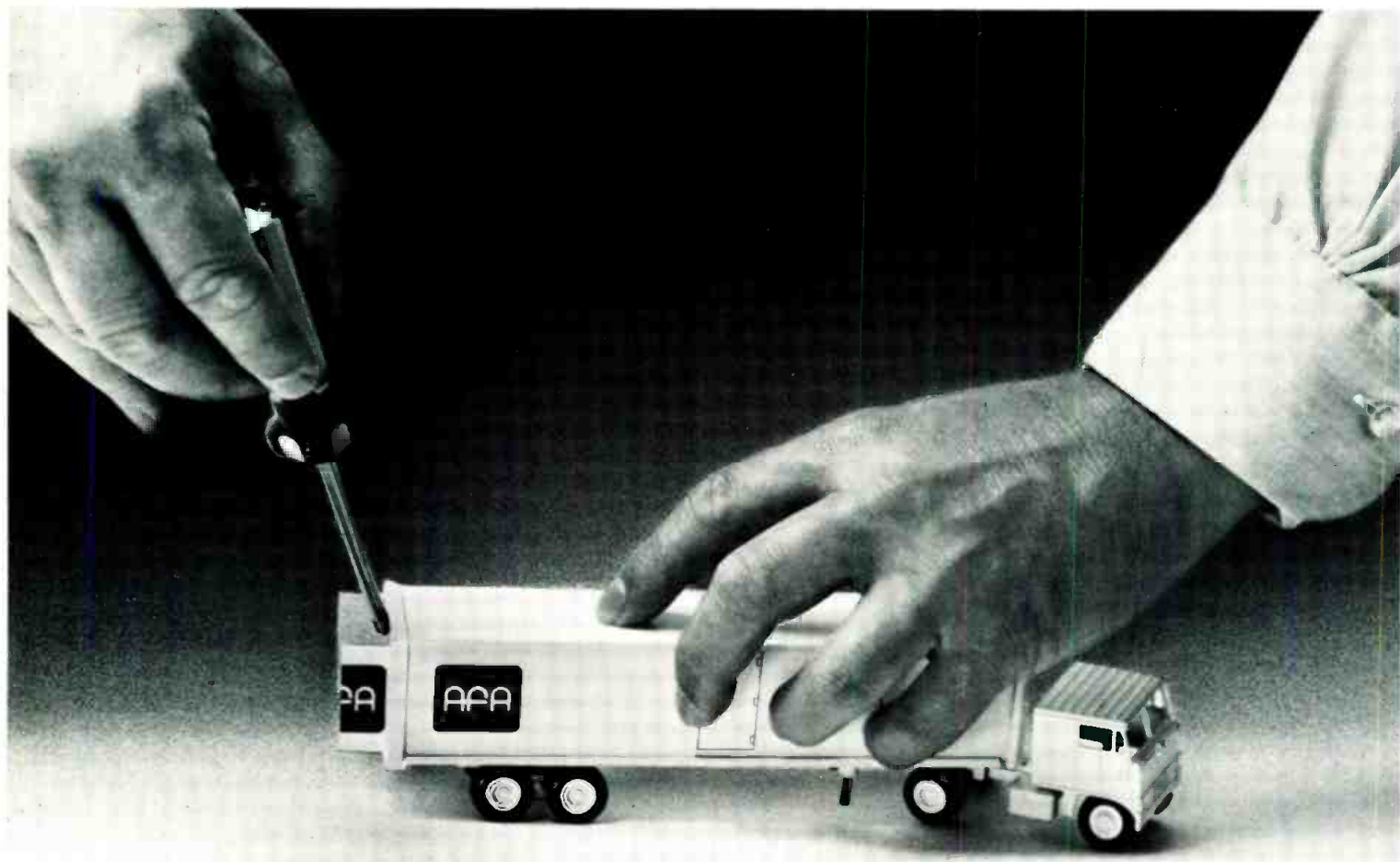

WE MAKE 'EM IN ALL SIZES!

We've been designing and building mobile video systems since 1976 when we delivered our first—a 40' production and post-production unit for the ABC-TV Network. Since then we've built video systems in every size and configuration.

And with each one—from "mini-vans" to giant units which put entire production and post-production operations on the road—we provide the same meticulous attention to planning and execution.

We make certain that all the equipment—from VTRs to switchers—is the most effective and efficient for the job. We design for safety, comfort and durability—carefully considering the problems of human engineering, power sources, air-conditioning, weight distribution and stress on the vehicle. And we see to it that your budget and delivery date is on target!

At AFA we believe there are no such things as *small* mobile systems. Only small designers!

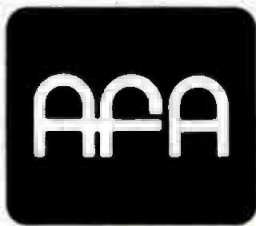

AFA SYSTEMS DIVISION

A DIVISION OF A. F. ASSOCIATES, INC.

BUILDING BETTER SYSTEMS BY DESIGN

100 Stonehurst Court, Northvale, NJ 07647 (201)767-1000

Circle 122 on Reader Service Card

www.americanradiohistory.com



SUPPLIERS:

ADC ✓ (1); ADM ✓ (1); Alpha Audio ✓ (2); Atlantic Research (1); Audio Technologies (1); Audio Acc. ✓ (1); Audisar ✓; Broadcast Technology ✓ (1); Datatronix ✓ (1); Emergency Alert (3); Farrtronics ✓ (1); Gorman-Redlich ✓ (3,4); Hedco ✓ (4); International Nuclear (3); Jenel (1); Johnson ✓ (3); Lemo ✓ (1); McCurdy ✓ (1,4); McMartin ✓ (3); Ramko ✓ (4); RTS ✓ (4); Sescom ✓ (1); Sphere ✓ (1); Symetrix ✓ (1); TFT ✓ (3); Trompeter ✓ (1); Tweed ✓ (1); Ward-Beck ✓ (1); Wireworks ✓ (1); World Video ✓ (4)



VIDEO, IMAGING

Cameras

TYPES:

- 1) Studio (30mm tubes)
- 2) Field (25mm tubes)
- 3) ENG, EFP (18mm tubes)
- 4) Lightweight (13mm tubes)
- 5) Single-tube cameras
- 6) Recorder/camera combos
- 7) B&W cameras
- 8) Cine cameras
- 9) Solid state cameras

SUPPLIERS:

Ampex ✓ (1,3,6); Arriflex ✓ (8); Asaca ✓ (7); Birns & Sawyer ✓ (8); Bosch ✓ (1,2,3,6); Camera Mart ✓ (3,8); Central Dynamics ✓ (1,2,3); Cinema Products ✓ (3,8); Colorado Video ✓ (7); Eumig ✓ (8); Harris Broadcast ✓ (1,2,4,9); Hitachi ✓ (1-7,9); Ikegami ✓ (1,2,3,6,7,8); Javelin ✓ (7,9); JVC ✓ (3,4,5); Marconi ✓ (1); NEC ✓ (3,9); Panasonic ✓ (2,3,5,6,7); Panavision ✓ (2,3); RCA Commercial ✓ (1,2,3,6); Sea-Cam ✓ (3); Sharp ✓ (3,5,7); Sony ✓ (1,2,3,5,6); Teledyne (9); Thomson-CSF ✓ (1-4,6); Toshiba ✓ (1,3); Tritronics (motion analysis); Westinghouse ✓ (5,7)

Camera Components

TYPES:

- 1) Lenses
- 2) Lens extenders
- 3) Filters
- 4) Pickup tubes
- 5) Standalone microprocessor CCUs

SUPPLIERS:

Amperex ✓ (4,5); Angenieux ✓ (1,2); Anton/Bauer ✓ (5); Belden ✓ (3); Calvert ✓ (4); Canon ✓ (1,2); Century Precision ✓ (1,2,3); Cinema Products ✓ (1); Colorado Video ✓ (1,2); F&B/Ceco (1,3); Film/Video Equip ✓ (2); Fujinon ✓ (1,2); Ikegami ✓ (1-5); Javelin ✓ (1,2); JVC ✓ (1,2); Lenzar (1); Panasonic ✓ (1); Panavision ✓ (1); RCA EO&D ✓ (4); RCA Solid State ✓ (4); Schneider ✓ (1,2); Warren R. Smith (1); Sony ✓ (5); Tamron ✓ (1); Tele-Cine ✓ (1,2,3); Thomson-CSF ✓ (4); Tiffen ✓ (3); Tritronics (1); Zei-Mark (1)

VTRs, VCRs

TYPES:

- 1) Quad
- 2) One-inch B
- 3) One-inch C
- 4) U-type VCR
- 5) Pro Beta VCR
- 6) Pro VHS VCR
- 7) Recorder/camera combos
- 8) Video cart, cassette automation systems

SUPPLIERS:

AF Assoc. ✓ (3); Ampex ✓ (1,3,7,8); Bosch ✓ (7,8); Calico Video (8); Central Dynamics ✓ (3); Channelmatic (8); CMC ✓ (1,3); Delcom (4); Hitachi ✓ (3,6,7); Intl. Video ✓ (8); JVC ✓ (4,6); Lake ✓ (8); 3M ✓ (3); Marconi ✓ (3); Media Concepts (6,8); Merlin ✓ (1,2,3); Odetics ✓ (8); Panasonic ✓ (4,6,7); Phasecom (8);

What You Should Know Before Buying an Animation System

The Dubner CBG-2

Many companies are offering advanced video graphics and animation systems. But all are not alike. To make sure you're getting exactly what you need, ask yourself these questions:

Reputation: Is the manufacturer recognized as an industry leader? Do they provide adequate training and ongoing support? How do previous buyers feel about the product?



Painting: Electronic "painting" allows an artist to draw images directly on the screen. What kind of "brushes" are available? Can you create your own? Can you cut and paste?



Geometrics: Are there any aids for creating geometric objects? Straight lines? Circles and ellipses? Curves? 3-D objects? What about surfaces and hidden line removal?



Text: Letters and symbols are an important part of graphic design. How easy is it to enter text? Do you have a wide choice of fonts and colors? Can characters be typed and repositioned directly on the screen?



Manipulation: Once an image is in the system, can it be modified? Scaled? Tilted? Repositioned? Recolored? Rotated with perspective? Can you magnify the image and change it at the pixel level?



Animation: What sorts of animation possibilities does the system offer? Color animation? Simple motion? True cel animation? Can you transform one object into another? What kind of aids are available to speed the process?



Storage and Playback: How many frames can you store on-line? Does image quality degrade in successive generations? Can a series of images be played back in real time, or is an external single frame recorder required?



All advanced video graphic systems include some of these features, but only one has them all—the Dubner CBG-2. Dubner's industry leadership has been recognized by the 1982 Emmy award for outstanding engineering development.

For a free demonstration of the Dubner CBG-2, call (201) 592-6500 or write:



DUBNER COMPUTER SYSTEMS INC.
158 Linwood Plaza, Fort Lee, New Jersey 07024
Circle 123 on Reader Service Card



RCA ✓ (1,3,7,8); Recortec ✓ (8,4); Sharp ✓ (6); Sony ✓ (3,4,5,7); Tech Elect. (8); Techtran ✓ (port. 1/4-inch)

Video Heads, Accessories

TYPES:

- (1) Replacement heads
- (2) Rebuilt heads
- (3) VTR rebuilding service
- (4) Head cleaners, degaussers
- (5) Alignment, tension gauges

SUPPLIERS:

AF Assoc. ✓ (3); Ampex ✓ (1,2,3,4); Allsop ✓ (4); R.B. Annis ✓ (4); CMC ✓ (1,2,3); Glentronix ✓ (2); Lauderdale (4); McManus ✓ (3); Merlin ✓ (3); Minneapolis Mag. ✓ (1,3); Nortronics ✓ (1,4,5); Rangertone ✓ (1,3); RCA Commercial ✓ (1,2,3); Saki ✓ (1); Spin Physics ✓ (1,3); Taber ✓ (1,3); Tentel ✓ (5); Texwipe ✓ (4)



Videotape, Film, Accessories

TYPES:

- (1) Two-inch tape
- (2) One-inch tape
- (3) 3/4-inch tape
- (4) 1/2-inch tape
- (5) Film stock
- (6) Tape cleaners, evaluators
- (7) Bulk erasers

- (8) Tape loaders
- (9) Empty reels, containers
- (10) Other

SUPPLIERS:

Agfa-Gevaert ✓ (3,4); Ampex ✓ (2,3,9); Allsop ✓ (6); R.B. Annis ✓ (7); Asaca ✓ (6); Audico ✓ (6,8); BASF ✓ (4); Calico Video (8); Calzone ✓ (9); CMC ✓ (7); Eastman Kodak ✓ (5); Environmental (9); Fidelipac ✓ (7); Fuji ✓ (1-4, 10); Garner ✓ (7); JVC ✓ (4); King (6,8); Koss (6); Lauderdale (7); 3M ✓ (1-6,8,9); Memorex ✓ (4); Nortronics ✓ (7); N.O.V.A. ✓ (6); Otari ✓ (8); Panasonic ✓ (3,4); PDM (4); Plastic Reel ✓ (9); Quanta ✓ (6); Recortec ✓ (6); Re-Play ✓ (10); RKO Tape (4); RTI (6); Sawyer (8,9); Smith-Victor ✓ (4); Sonar ✓ (7); Sony ✓ (2,3,4); Studio Film ✓; Superex (7); Taber ✓ (7,9); TDK ✓ (4,6); Wide Range ✓ (7)

Slow Motion Recorders

TYPES:

- (1) Disc action recorder
- (2) Video animation controller
- (3) Slow scan recorder
- (4) VTR slow-mo controller

SUPPLIERS:

Ampex ✓ (4); Aurora (2); Computer Ops. (2); Convergence ✓ (2); Eigen ✓ (1,2); Grove (2); Hitachi ✓ (4); Interand ✓ (2); Lyon Lamb ✓ (2); 3M ✓ (4); MPB ✓ (2); Oktel ✓ (1); RCA Commercial ✓ (4); Sony ✓ (4)

Telecines, Film Equipment

TYPES:

- (1) Solid-state telecines
- (2) Telecine cameras

THE CHOICE IS YOURS!



THE AUDIOPAK A-2 OR THE STEREO PHASED AA-3 BROADCAST CARTRIDGE

**Capitol Audiopak Broadcast Cartridges—
for stations who care how they sound.**

Both Audiopak carts offer extremely low wow and flutter; a positive brake system which stops the tape, not the hub, assuring accurate cueing. Unsurpassed reliability is assured because we manufacture the tape and all other components in the cartridge. Moreover, all carts are 100% tested before shipping.

The AA-3 offers excellent stereo phase stability. It's loaded with Capitol's own Q17 HOLN tape which extends frequency response and headroom to provide studio sound quality.

CAPITOL MAGNETIC PRODUCTS
A Division of Capitol Records, Inc.
6902 Sunset Blvd.
Hollywood, California 90028



©1980 CAPITOL RECORDS, INC.



- (3) 16/35mm telecine projectors
- (4) 35mm slide projectors
- (5) Optical multiplexers
- (6) Sprocketed film transports
- (7) Telecine color correctors
- (8) Auto light control

SUPPLIERS:

AF Assoc. ✓ (1); Beston ✓ (3); Bosch ✓ (1,5,7); Buhl ✓ (4,5); Corporate Comm. ✓ (7); Dubner ✓ (7); Eastman Kodak ✓ (3); Fairchild ✓ (1); Alan Gordon ✓ (4); Hitachi ✓ (2); Ikegami ✓ (2,7); Kalart Victor ✓ (3,5); KB ✓ (6); Laird ✓ (3,4,5); L-W ✓ (3); Magnasync/Moviola ✓ (3,6,7); Magna-Tech ✓ (3,6); Marconi ✓ (1,7); Multi-Track ✓ (3,6); North Hills (1); Nytone (3,5,7); W.A. Palmer ✓ (3); Panavision ✓ (2); Rangertone ✓ (3,5,6); Rank Precision ✓ (2,3,4,7); RCA Commercial ✓ (2-5,7); Spindler & Sauppe ✓ (4); Teledyne (video-to-film); Telex ✓ (3,4); Tritronics (5); Wide Range ✓ (6); Zei-Mark (3,4,5)

Electronic Art, Graphics

TYPES:

- (1) Character generators
- (2) Character generator/framestores
- (3) Digital art/paint systems
- (4) Digital still stores
- (5) Bit pad digitizers
- (6) Camera/VTR digitizers
- (7) Weather symbol inserters
- (8) "Draw on screen" systems

SUPPLIERS:

Abekas ✓ (4); ADDA ✓ (4); Ampex ✓ (4); Apert-Herzog ✓ (4); Aurora ✓ (3,6,7); Barda ✓ (1); Beston ✓ (1); Bosch ✓ (1,3); British Videotex (1); Chyron ✓ (1,2,3,5,7,8); Colorado Video ✓ (4); ColorGraphics ✓ (3,8); Comprehensive Video ✓ (1); Computer Graphics Lab ✓ (3,6,8); Computer Video ✓ (1); Datum ✓ (1);

Dubner ✓ (1,3,4-8); EEG ✓ (1); Environmental Satellite ✓ (7); For-A ✓ (1,8); Grove (1,2,3,6); Harris Broadcast ✓ (4); Harris Video ✓ (4); Interand ✓ (3,5,7,8); Kavouras ✓ (7); Knox ✓ (1); Laird ✓ (1); Logica ✓ (3); 3M ✓ (1,6); McInnis Skinner ✓ (1,3,7); MCI/Quantel ✓ (1-4); MPB ✓ (1); QSI ✓ (1); Quanta ✓ (1); Rank ✓ (4); Seem ✓ (1); Shintron ✓ (1); Spectra ✓ (3,7); Texscan ✓ (1,8); Thalner ✓ (1); Thomson-CSF ✓ (1,2,5,7); Vectrix ✓ (7); Xiphias ✓ (3,5,7)

Production Switchers

TYPES:

- (1) Portable
- (2) Large studio
- (3) Compact studio/mobile
- (4) Automated, microprocessor-controlled
- (5) Post-production

SUPPLIERS:

Ampex ✓ (2-5); Asaca ✓ (1,3); Beaveronics ✓ (1,2,3,5); Central Dynamics ✓ (1-5); Comad (1); Commerce Airborne ✓ (1); Crosspoint Latch ✓ (4,5); Echolab ✓ (3,4,5); Grass Valley ✓ (2-5); Image Video ✓ (1,3); Industrial Sciences ✓ (1-5); International Nuclear (1-5); Kaitronics ✓ (1,3); Lang ✓ (1); Ross ✓ (1,2,3,5); Shintron ✓ (3); Siegel ✓ (5); Toshiba ✓ (1,2); Vital ✓ (1-5)

Special Effects

TYPES:

- (1) Digital efx processors
- (2) Standalone efx generators
- (3) Colorizers
- (4) RGB chromakeyers
- (5) Encoded chromakeyers
- (6) Title keyers
- (7) Downstream keyers

A GRAPHICS AND ANIMATION SYSTEM THAT GATHERS ALL THE WEATHER...

before the Weatherman even arrives at the studio.

TRITON X

It's all here. And it's all automatic. The Triton X Graphics & Animation System is the complete single-source meteorology machine. It'll gather radar, satellite, national weather circuit data or special weather packages...all in real-time...all the time. And Triton X updates the weather information, archives it, animates it, or manipulates it any



way you want... automatically. The Triton X display is always perfect too—no jaggies, never. That's just on its own. You should see what Triton X can do with a little encouragement. Give us a call today and find out how affordable Triton X can be for you. And tell your weatherman he can sleep in...Triton X is covering for him.

Kavouras

800-328-2278

Federal Aviation Building, 6301 34th Ave. So., Minneapolis, MN 55450
In Minnesota call 612-726-9515



- (8) Nonadditive keyers
- (9) Compressor/positioners

SUPPLIERS:

ADDA ✓ (9); Ampex ✓ (1); Asaca ✓ (2); Beaveronics ✓ (2,3,4,6,7); Broadcast Video ✓ (2,4-7); Central Dynamics ✓ (2-7); Chyron ✓ (1); Colorado Video ✓ (3); Computer Graphics ✓ (1); Convergence ✓ (1); Crosspoint Latch ✓ (4,5,7); Dubner ✓ (2); Dynair ✓ (2); For-A ✓ (3,6); Graham-Patten ✓ (6,7); Grass Valley ✓ (1,4-7); Grove (1); Image Video ✓ (2,7); Industrial Sciences ✓ (2,4,5,7); Interand ✓ (1,2,3); International Nuclear (2,5,7); JVC ✓ (2); Knox ✓ (3); 3M ✓ (3); Marconi ✓ (3); MCI/Quantel ✓ (1,2,9); Multidyne ✓ (7); NEC ✓ (1,2); Panasonic ✓ (2,3,4,7); Shintron ✓ (5); Siegel ✓ (4,6,8); Telemet (4,5); Thomson-CSF ✓ (4,5,6,7,8); Toshiba ✓ (1,2); Ultimatte ✓ (4); Vital ✓ (1,2,3)



Master Control Switchers

TYPES:

- (1) Manual
- (2) Automated
- (3) Business automation interfaced

SUPPLIERS:

Ampex ✓ (1,2); Central Dynamics ✓ (1,2,3); Data Comm. ✓ (3); Dynair ✓ (1,2,3); Grass Valley ✓ (1,2); Image Video ✓ (1,2,3); Industrial Sciences ✓ (1,2); International Nuclear (1,2); Matrix Systems (1,2); Utah Scientific ✓ (1,2); Vital ✓ (1,2,3)

Routing Switchers

TYPES:

- (1) Parallel interface
- (2) Serial interface

SUPPLIERS:

AVL Digital ✓ (1,2); Central Dynamics ✓ (1,2); Datatek ✓ (2); Di-Tech ✓ (1,2); Dynair ✓ (2); Glentronix ✓ (1,2); Grass Valley ✓ (1,2); Grumman ✓; Hedco ✓ (1,2); Image Video ✓ (1,2); Industrial Sciences ✓ (1,2); International Nuclear (1,2); Kaitronics ✓ (1,2); 3M ✓ (1,2); NEC ✓ (1,2); Omicron ✓; Telemet (1,2); Ultra Audio ✓ (1); Utah Scientific ✓ (2); Vamco (1,2); Videotek ✓; Vital ✓ (2)

Machine Control, Technical Automation

TYPES:

- (1) Parallel interface
- (2) Serial interface
- (3) VI systems

SUPPLIERS:

Auburn Instr. (1); Avonix ✓; Control Video ✓ (1,2,3); Datatek ✓ (2); Digital Services ✓; Dynair ✓ (2); EECO ✓ (3); Engineering Lab (1,2,3); Grass Valley ✓ (1,2); Image Video ✓ (1,2); Kaitronics ✓ (1); Kavco ✓ (1,2); 3M ✓ (2); Recortec ✓ (1); Torpey ✓ (2); Utah Scientific ✓ (2); Vamco (1,2,3); Vital ✓ (2)

Post-Production

TYPES:

- (1) Editor/controllers
- (2) Multisource editors
- (3) SMPTE time code generators, readers
- (4) SMPTE time code synchronizers
- (5) Proprietary time code systems

SUPPLIERS:

Ampex ✓ (1,2,3); Adams-Smith ✓ (3,4); Applied Digital (4); Audio Kinetics ✓ (3,4); Automated Studio Technologies ✓ (2); Bosch ✓ (1); BTX ✓ (1,3,4); Cipher Digital ✓ (3); CMX ✓ (1,2); Coherent ✓ (3); Control Video ✓ (1-4); Convergence ✓ (1,2,3);

Datatron ✓ (1-5); Datum ✓ (1,3,4,5); EECO ✓ (1,3,4,5); Electro & Optical ✓ (3,4); ESE ✓ (3,5); For-A ✓ (3); Glentronix ✓ (3,4); Gray ✓ (3); Grumman ✓ (3); Harris Video ✓ (1); Interactive ✓ (1-5); Intl. Video ✓ (1,2); Jatex ✓ (1,2,3,5); JVC ✓ (1,3); Kaitronics ✓ (3); Lyon Lamb ✓ (1); Multidyne ✓ (3,4,5); Multi-Track ✓ (3,4); Omicron ✓ (1); Panasonic ✓ (1,3); RCA Commercial ✓ (1,2); Sawyer (1); Shintron ✓ (3); Skotel ✓ (3); Sony ✓ (1,2,3); Telcom ✓ (3); United Media ✓ (1-5); Videomedia ✓ (1-5); Vital ✓ (3,4); Wide Range ✓ (3)

Video Signal, Sync Generators

TYPES:

- 1| Synch
- 2| Black burst
- 3| Color bar
- 4| Multiburst
- 5| Staircase ramp
- 6| Source identification
- 7| Safe title area
- 8| Countdown
- 9| Video slate board

SUPPLIERS:

Amtron ✓ (1,7); Asaca ✓ (1,2,3,4); Automation Techniques ✓ (2,3); AVL Digital ✓ (1,2,4,8); Bosch ✓ (3,6); Broadcast Video ✓ (7); Central Dynamics ✓ (2); Colorado Video ✓ (1); Crosspoint Latch ✓ (1,2); Datatek ✓ (2); EEG ✓ (6); For-A ✓ (1,2,3,7,8); Grass Valley ✓ (1,2); Gray ✓ (7); Industrial Sciences ✓ (1,2,3); International Nuclear (2); Javelin ✓ (6); Kaitronics ✓ (3); Lang ✓ (6); Leitch ✓ (1-7); Lenco ✓ (1-5); 3M ✓ (1,2,3); Marconi ✓ (1,2,3); McMichael ✓ (6,8); Multidyne ✓ (1-6,8,9); Omicron ✓ (1); Panasonic ✓ (1,3); QSI ✓ (3,6,8,9); Shintron ✓ (1); Siegel ✓ (1,2); Sigma ✓ (1,2,3); Tektronix ✓ (1-6); Telemet (1,3,4,5); Thalner ✓ (8); Torpey ✓ (8); Video Aids ✓ (1,2); Visual Info. ✓ (1,3,4,5); World Video ✓ (3)

Video Signal Processing

TYPES:

- 1| NTSC encoders
- 2| Decoders
- 3| Comb filter decoders
- 4| Video delay lines
- 5| Video filters
- 6| Video signal, cable equalizers
- 7| Dropout compensators

SUPPLIERS:

Adwar ✓ (1); Allen Avionics ✓ (4,5,6); Analog Devices ✓ (1); Asaca ✓ (1); Bosch ✓ (1); Broadcast Video ✓ (1-5); Central Dynamics ✓ (6); Coastcom (5); Datum ✓ (1,2); Digital Video Systems (3); DiTech ✓ (6); Dynair ✓ (6); Fairchild ✓ (4); Faroudja ✓ (2,3); Graham-Patten ✓ (6); Hedco ✓ (6); International Nuclear (6); Leitch ✓ (4,6); Lenco ✓ (1,2,4); Marconi ✓ (1,2,6); Microwave Filters ✓ (5); Multidyne ✓ (6); North Hills (5); Siegel ✓ (1,2,3,7); Superex (5,6); Telemet (3,6); TEA ✓ (4,5,6); TTE ✓ (3,5);

Digital Processing

TYPES:

- 1| TBCs
- 2| Field synchronizers
- 3| Frame synchronizers
- 4| Framestores
- 5| TBC/framestores
- 6| Noise reducers
- 7| Image enhancers
- 8| Color correctors
- 9| Video multiprocessors
- 10| Standards converters

SUPPLIERS:

ADDA ✓ (1,3,4,5); AF Assoc. ✓ (10); Ampex ✓ (1); Analog Devices ✓; Apert-Herzog ✓ (3); Broadcast Video ✓ (8); Colorado Video ✓ (4); Digital Video Systems ✓ (1,2,3); Digivision ✓ (7); Dubner ✓ (8); Eigen ✓ (4,6); Faroudja ✓ (6,7,8); Fortel ✓ (1,3,6,7); For-A ✓ (1,3,7,8); Grumman ✓ (3); Harris Broadcast ✓ (1,3,4,5); Harris Video ✓ (1,3,5); Hitachi ✓ (1); Marconi ✓ (8); MCI/Quantel ✓ (1-6,10); McMichael ✓ (10); Merlin ✓ (1); Microtime ✓ (1,3-7); NEC ✓ (3); NTI ✓ (4); Oki ✓ (10); Phasecom (1);

Progress by Design

Videotek's philosophy is to progressively design & refine the quality, function, and reliability of our products, and to provide equally aggressive service-after-the-sale.

Videotek's state-of-the-art TSM-5A Waveform Monitor and VSM-5A Vectorscope reflect this on-going commitment, with such innovative features as Internal Graticule for precise parallax-free signal analysis, and Non-Glare Shields to eliminate distracting ambient light. TSM-5A also includes selectable 1H mode for easy one-line viewing, and $0.5 \mu\text{s}/\text{div}$ scan rate for the most accurate time-base measurements.

Our popular Studio 12 picture monitor includes, as standard equipment, the features found on monitors costing twice as much: A-B Split Screen, Selective H-AFC, High Voltage Regulation, ACC-Defeat, Preset Controls, Pulse Cross, Underscan, External Sync plus more.

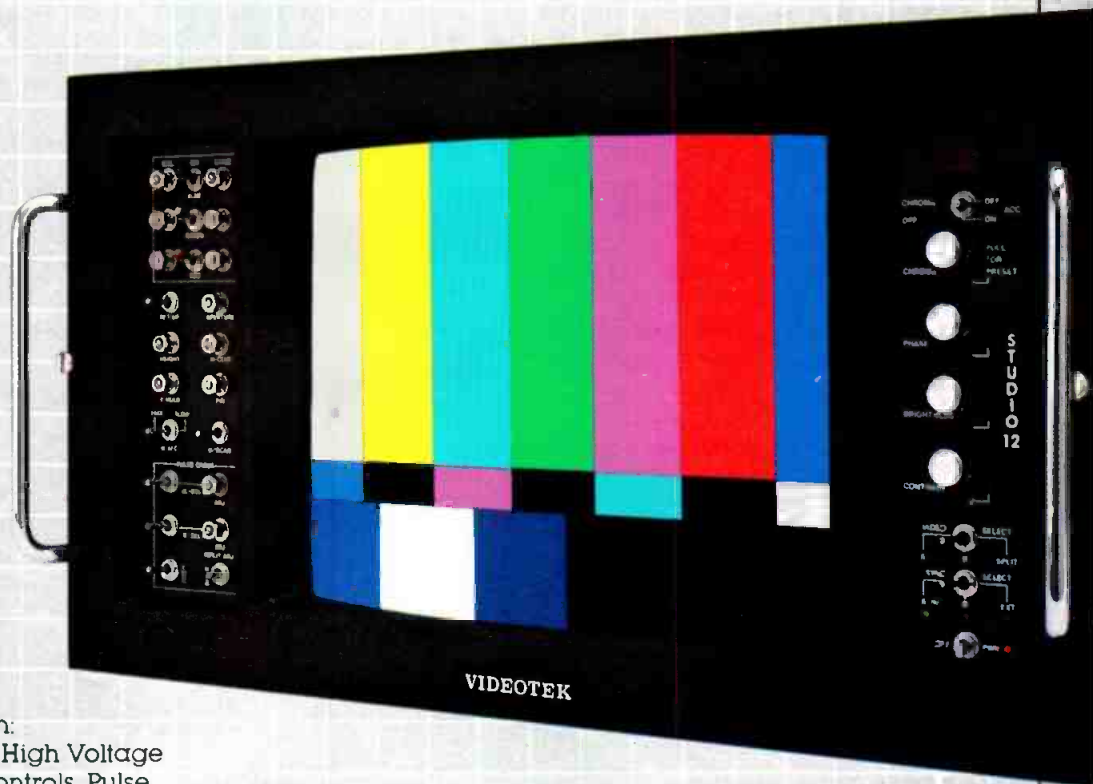

(all available in PAL standard.)

In only 7 years, Videotek has become an industry leader. We design and build more sizes and configurations of color monitors than anyone—worldwide! And our 1981 "Distinguished Video Industries Service Award" stands as a testimonial to our commitment to your needs.

Now that's Progress...by Design.



**VIDEOTEK
INC.**



HAWKEYE

ONE-MAN GANG SHOOTS 25 SET-UPS IN 12 HOURS



Mississippi ETV has a one-man equipment gang on the road shooting and recording their new documentary series "Mississippi Roads". They're able to do it because of the versatility of HAWKEYE!

In a recent production covering the restoration of the Natchez Eola Hotel, the HAWKEYE recording camera and that one-man equipment gang were able to cover 25 different set-ups in 12 hours under a producer's direction.

"HAWKEYE gets into tough-to-shoot places," reports Larry Holden, director of production for Mississippi ETV. "It speeds our coverage and its small size puts on-camera individuals at ease. It gives us high quality productions in a cost-effective way."

"Outstanding . . . Impressive"

"The camera video quality is outstanding and recorder performance is impressive. We've been putting HAWKEYE through a tough grind for nearly a year now and we haven't had any major problems."

Segments for "Mississippi Roads" are shot with the recording camera . . . a HAWKEYE studio recorder is used with existing 1" VTRs for multiple generation editing.

HAWKEYE is versatile. It can be easily integrated into your present equipment complement. Ask your RCA Representative for the HAWKEYE facts—camera, recorder, recording camera, or complete systems. Have HAWKEYE Your Way. RCA, Bldg. 2-2, Camden, NJ 08102.

Illustrations show HAWKEYE in a variety of locations and configurations at the Natchez Eola Hotel.

RCA

Circle 127 on Reader Service Card



RCA Commercial ✓ (1); Siegel ✓ (7,8); Sony ✓ (1); Superex (7,9); Tektronix ✓ (3); Thomson-CSF ✓ (1,2,3,5-8); Toshiba ✓ (4); Video intl. (10)

Video Amplifiers

TYPES:

- (1) Processing amps
- (2) Pulse amps
- (3) Video DAs
- (4) Subcarrier amps

SUPPLIERS:

Automation Techniques ✓ (1); AVL Digital ✓ (2,3); Broadcast Video ✓ (1,3); Central Dynamics ✓ (2,3,4); Channelmatic (3); Comad (3); Commerce Airborne ✓ (3); Datatek ✓ (2,3); Di-Tech ✓ (3); Dynair ✓ (2,3); For-A ✓ (3); Graham-Patten ✓ (2,3,4); Grass Valley ✓ (1-4); Grumman ✓ (1); Hedco ✓ (2,3,4); Industrial Sciences ✓ (1-4); International Nuclear (1-4); Javelin (3); Knox ✓ (1,3); Lang ✓ (3); Leitch ✓ (1,2,3); Lenco ✓ (1-4); Marconi ✓ (2,3); Omicron ✓ (3); Opamp ✓ (2,3); Panasonic ✓ (2,3); QSI ✓ (3); Shintron ✓ (2,3,4); Siegel ✓ (1); Sigma ✓ (1-4); Superex (3); Telemet (2,3); TEA ✓ (3); Vamco (3); V.A.M.P. ✓ (iso amps); Video Aids ✓ (2,3); Videotek ✓ (2,3,4); Vital ✓ (2,3)

- (3) RGB
- (4) Dc portable
- (5) Video projectors
- (6) Monitor calibrators

SUPPLIERS:

Amtron ✓ (1,2,3); Asaca ✓ (2,3,4,6); Avonix ✓ (5); Bosch ✓ (2,3); Central Dynamics ✓ (2); Cinema Products ✓ (1,2); Colorado Video ✓ (1,2); Conrac ✓ (1,2,3); Elector ✓ (2,3); Electrohome ✓ (2,5); Electro & Optical ✓; General Electric Video ✓ (5); Heath (5); Hitachi ✓ (1,3); Ikegami ✓ (1,2,3); Image Magnification ✓ (5); Javelin ✓ (1,3); JVC ✓ (2,3,4); Lectrotech (2); Leitch ✓ (6); McMichael ✓ (2,3); Minolta ✓ (6); Panasonic ✓ (1-5); Power-Optics ✓ (6); Rohde & Schwarz ✓ (1,2,3); Sharp ✓ (2); Sony ✓ (1,2,5); TEA ✓ (6); Tektronix ✓ (2,3,6); Tritronics (2); V.A.M.P. ✓ (3); Videotek ✓ (2,3,4); World Video ✓ (2,3)

Other Video Equipment

TYPES:

- (1) Signal multiplexes
- (2) Test charts, slides
- (3) Video business automation hardware
- (4) TV newsroom computers
- (5) Other

SUPPLIERS:

Paul Adams ✓ (3); Anacomp ✓ (3); Basys ✓ (4); Briner-Chase ✓ (3); Colorgraphics ✓ (4); Columbine ✓ (3); Computer Business (3); Control Video ✓ (3); Cox ✓ (3); Data Comm. ✓ (3); Edcor ✓ (1); Eigen ✓ (5); Glentronix ✓ (2); Grass Valley ✓ (5); Heath (4); Hewlett-Packard ✓ (3); Image Resource ✓ (5); Industrial Sciences ✓ (5); Jefferson Data ✓ (3,4); Kalart Victor ✓ (5); Kaman ✓ (3,4); Magnicom ✓ (3); Marconi ✓ (2); McInnis Skinner ✓ (4); Microtime ✓ (5); NEC ✓ (1); North Hills (1); W.A. Palmer ✓ (5); Porta-Pattern ✓ (2); Quan-



Video Monitors

TYPES:

- (1) Monochrome
- (2) NTSC color



Sound Management Technical Advisory No.

The Amazing Human Ear

2

These days everyone is concerned with the dreaded term, "listener fatigue". Things such as distortion and...even signal processing can turn your listeners off. That's why the Valley People 610 employs our patented VCA to achieve low noise, low distortion operation. It also uses Linear Integration Detection to deliver sonic "naturalness".

To explain, the peak voltage of a signal unfortunately bears little relationship to loudness as perceived by the human ear, which responds to power levels. Complex waveforms of equal loudness to a human will be processed to unequal loudness by a peak detector, because it reads the peak voltage level.

Although an rms-responding detector will produce an output analogous to the waveform's power level, this detection method does not compensate for the frequency response of the human ear.

The response of Linear Integration Detection emulates the human ear. This detection scheme's reaction is based on the degree of waveform complexity. The more complex waveforms exit the 610 at a higher absolute level than do simpler waveforms, thus preserving their correct musical relationship.

The Valley People Model 610 Dual Compressor/Expander...processing your signal the way your listeners want to hear it!

VALLEY PEOPLE, INC. • P.O. Box 40306/2820 Erica Place • Nashville, Tenn. 37204 • 615-383-4737 • TELEX 558610 VAL PEOPLE NAS
Export: GOTHAM EXPORT CORPORATION, NY, NY/TELEX 129269

Circle 128 on Reader Service Card



ta ✓ (4,5); Recortec ✓ (5); RE ✓ (1); RTI (3); Warren R. Smith ✓ (5); Telesource ✓ (4); TVNS (4); Visual Info. ✓ (2); Frank Woolley ✓ (animation graphics)

LIGHTING, POWER, SUPPORT

Camera, Microwave Support

TYPES:

- (1) Tripods, heads
- (2) Pedestals
- (3) ENG braces
- (4) Remote pan/tilt systems
- (5) Camera, lens stabilizing systems
- (6) Helicopter rigs
- (7) Cranes
- (8) Dollies

SUPPLIERS:

Arriflex ✓ (1,5); Birns & Sawyer ✓ (1,8); Bogen ✓ (1,8); Camera Mart ✓ (1,2,5); Cinema Products ✓ (1,5); Cine 60 ✓ (3,9); Commerce Airborne ✓ (6); Davis & Sanford ✓ (1,8); ENG Helicopter ✓ (5,6); Alan Gordon ✓ (1,8); Harris Broadcast ✓ (1,4,6); Heitz ✓ (1,8); Innovative ✓ (1,2,3,8); Javelin ✓ (4); Lee ✓ (7,8); Listec ✓ (1,2,4,7,8); Matthews ✓ (1,4,7,8); Miller Professional ✓ (1,8); O'Connor ✓ (1,2); Quick-Set ✓ (1,2,8); Sachtler ✓ (1,3); Stena ✓ (5); Smith-Victor ✓ (1)

Lighting

TYPES:

- (1) Lamps

- (2) HMI, CSI fixtures
- (3) Quartz fixtures
- (4) Stands, rigging
- (5) Lighting control boards
- (6) Dimmer packs
- (7) Diffusion, efx material
- (8) Cyc lighting
- (9) Other (cycs, etc.)

SUPPLIERS:

Peter Albrecht (4); Anton/Bauer ✓ (3); Arriflex ✓ (2,4); Atlas Sound ✓ (4); Barbizon ✓ (1-9); Bardwell & McAlister ✓ (1,3,4,8); Belden ✓ (7); Birns & Sawyer ✓ (3,7); Bogen ✓ (3); B-W Lighting ✓ (1-6,8); Calvert ✓ (1); Cinema Products ✓ (1,2,3); Cinemills ✓; Colortran ✓ (1,3-8); Comprehensive Video ✓ (3,7,8); Cool Light ✓ (1,3); Electro Controls (5,6); Electronics Diversified ✓ (5,6); F&B/Ceco (1-4,7,8); Frezzolini ✓ (1,3,4,7); General Electric Lighting ✓ (1,3); Alan Gordon ✓ (9); Graphic Express ✓ (9); Great American ✓ (1,2,3,5,8,9); Grosh ✓ (4); GTE/Sylvania ✓ (1); Heitz ✓ (4); Ideal (6); Janson ✓ (1,3,5,9); Kliegel ✓ (3-6,8); Lee ✓ (1-8); Lowel-Light ✓ (9); LTM ✓ (1-5); Matthews ✓ (3,4,7); Mole-Richardson ✓ (1-8); Olesen ✓ (1-7); Osram ✓ (1,2); Packaged Lighting ✓ (3-8); Phoebus ✓ (1-4); Polites (4); Rainbo ✓ (9); Rosco ✓ (7); Skirpan ✓ (5,6); Smith-Victor ✓ (1,3,4,7); Strand Century ✓ (2-6,8); Superior ✓ (6); Syracuse ✓ (4); Teatronics (5,6); Teledyne Big Beam (emergency); Theatre Techniques ✓ (5,6); Theatrical Services ✓ (1-9); TVI ✓ (1,3-8)

Power Supplies

TYPES:

- (1) Nicad batteries, chargers
- (2) Silver-zinc batteries, chargers
- (3) Lead-acid batteries, chargers
- (4) Power generators
- (5) AC power dividers

UNCOMPROMISING WIRELESS MICROPHONES

Finally, you can choose a wireless mic to fit the application. The Telex WHM-300, the electret wireless transmitter mic for uncompromising speech clarity. Or a Telex WHM-400 dynamic wireless transmitting mic for vocal entertainment with rich, full bodied audio quality. Both elegantly tapered and without trailing antenna wires. Or select the miniature electret WLM-100 lavalier mic (or any standard dynamic mic) with our belt-pack transmitter.

Combined with the superb Telex dual diversity* FM receiver, you'll have a wireless system that is as good as any hard wired mic, and at a reasonable price. Write us today for full details.

Quality products for the Audio Professional

TELEX

TELEX COMMUNICATIONS, INC.

9600 Aldrich Ave. So., Minneapolis, MN 55420 U.S.A.
Europe: Le Bonaparte, Office 711, Centre Affaires Paris Nord 93153 Le Blanc-Mesnil France

*U.S. Patent No. 4293955. Other patents applied for.



- (6) Inverters, converters
- (7) Other

SUPPLIERS:

Alexander ✓ (1); Anton/Bauer ✓ (1,2,5); Arriflex ✓ (1); Birns & Sawyer ✓ (1); B-W Lighting ✓ (1); California Inst. ✓ (4,6); John Chiles (1); Christie ✓ (1); Cinema Products ✓ (1); Cine 60 ✓ (1,7); Colortran ✓ (1); Enerlite ✓ (1); F&B/Ceco (1,4); Frezzolini ✓ (1,6); G&M (1,3,5,6); JVC ✓ (1); Leader Inst. ✓ (7); Lee ✓ (1,4,5,6); LTM ✓ (1,2,3); Mole-Richardson ✓ (4); Motorola ✓ (6); North Wind (3,4,6,7); Onan ✓ (4); Packaged Lighting ✓ (5); PEP ✓ (1,6); Perrott ✓ (1,2,3); Portable Energy ✓ (1,3); Smith-Victor ✓ (3,6); Teledyne Energy (4); Topaz ✓ (6); Vanner ✓ (6)



Teleprompters

TYPES:

- (1) Monitor-based
- (2) Scroll entry
- (3) Keyboard entry
- (4) ENG/EFP portable

SUPPLIERS:

Beston ✓ (3); Cinema Products ✓ (4); Listec ✓ (1); Q-TV ✓ (1-4); Telescript ✓ (1)

Transportation Cases

TYPES:

- (1) Foam insert
- (2) Rack configuration
- (3) Editing, production consoles

SUPPLIERS:

Anvil ✓ (1,2,3); William Bal ✓ (1,2); B-W Lighting ✓ (1,2); Calzone ✓ (1,2,3); Cases, Inc. ✓ (1,2,3); Center Video (3); Environmental (1,2); Excalibur ✓ (1,2,3); Fiberbilt ✓ (1,2); Hardigg ✓ (1,2); Kangaroo (nylon); Lee-Ray ✓; Lipsner-Smith ✓ (3); LTM ✓ (1); Parsons ✓ (1); Plastic Reel ✓ (1,2); Porta-Brace ✓ (1); RTI ✓ (2,3); Star Case ✓ (1,2,3); Thermodyne ✓ (1,2); Viking ✓ (1,2); Winsted ✓ (3)

Set Design

TYPES:

- (1) Modular news, studio sets
- (2) Scenery construction
- (3) Scenery rigging
- (4) Props, materials

SUPPLIERS:

Peter Albrecht ✓ (3); Arben ✓ (1-4); Gagnon LaForest ✓ (3); Grosh ✓ (1,2,3); Janson ✓ (2,3,4); Rees ✓ (1); Syracuse ✓ (3); Theatre Service ✓ (3); TVI ✓ (2,3,4); Uni-Set ✓ (1)

RF, Transmitting/Receiving Equipment, Antennas, Towers,

Transmitters

TYPES:

- (1) AM
- (2) FM
- (3) UHF
- (4) VHF
- (5) LPTV
- (6) Translators

SUPPLIERS:

Acrodyne ✓ (3-6); Anixter-Mark (3,5); Bayly ✓ (2,3,4); Broadcast Electronics ✓ (2); Central Dynamics ✓ (3,4); Comark ✓ (3); Continental Electronics ✓ (1,2); Elcom Bauer ✓ (1,2); EMCEE ✓ (3-6); Harris Broadcast ✓ (1-4); International Microwave (1,2); Larcen ✓ (2,3,4,6); Loral (2); LPB ✓ (1); Marconi ✓ (1-4); McMartin ✓ (1-6); Nautical Electric ✓ (1); NEC ✓ (2,3,4); Power Pak ✓ (6); QEI ✓ (2); Radio Systems ✓ (1); RCA Commercial ✓ (1-4); Rodelco ✓ (6); Rohde & Schwarz ✓ (3,4); Ken Schaffer ✓ (2); Television Tech. ✓ (3-6); Tepco (5,6); Thomson-CSF ✓ (5); Townsend ✓ (3-6)

RF Power Equipment

TYPES:

- (1) RF amplifiers
- (2) RF power tubes
- (3) AM exciters
- (4) AM stereo exciters
- (5) FM exciters
- (6) TV exciters
- (7) RF attenuators
- (8) RF converters
- (9) RF filters
- (10) RF loads
- (11) RF switches
- (12) Power dividers
- (13) Diplexers
- (14) Stereo generators
- (15) Modulators
- (16) Other

SUPPLIERS:

Alford (13); Amperex ✓ (2); AVA (1,7,9); Barker & Williamson (9,10); Bayly ✓ (1); Bird ✓ (7,9,10,11); Blonder-Tongue ✓ (1,9,10); Broadcast Electronics ✓ (1,5,14); Broadcast Microwave ✓ (1,9,13); Calvert ✓ (1,2); Catel ✓ (1,8,14,15); Ceco ✓ (2); Central Dynamics ✓ (6); Cetec Antennas ✓ (9,12,13); Coastcom (13); Coaxial Dynamics (9-12); Comark ✓ (1,6-9,11,12,13,15); Comtech ✓ (15); Continental Electronics ✓ (1,4,5,9,10,13,14); CSP ✓ (9-13,16); Delta (11); Dielectric (10,11); Dyma ✓ (11); Dynair ✓ (15); Econco (2); Eidson (16); Elcom Bauer ✓ (3,5); Electro Impulse ✓ (10); Harris Broadcast ✓ (3-6,14,15); Information Transmission (6,15); International Microwave (1); ITT ✓ (11); Kahn ✓ (4,14); Kilovac (11); Larcen ✓ (1,5,6,13); LPB ✓ (3); M/A-COM ✓ (9,10,13,16); Magnecraft ✓ (11); McMartin ✓ (1,4,5,6,14,15); Micro Comm. (9-13); Microdyne ✓ (15); Microwave Filter ✓ (9,12,13); Moseley ✓ (12,14); Motorola ✓ (4); Mu-Del ✓ (1,7,8,9,13); Nautical Electric ✓ (1,3,4,14,15); NEC ✓ (5); North Hills (12); Oak ✓ (8); Orban ✓ (14,16); Phasecom (15); Philips T&M ✓ (6,14,15); QEI ✓ (1,5,14); RCA Commercial ✓ (5,6); RCA EO&D ✓ (2); RCA Solid State ✓ (2); RE ✓ (14); RF Technology ✓ (1); RMS (11); Rohde & Schwarz ✓ (15); Scala (12); Scientific-Atlanta (12,15); Shively ✓ (9-13); Singer Broadcast ✓ (3,5,14); Solutech (9); SWR ✓ (11); Telemet ✓ (15); Television Tech. ✓ (1,5,12,15); Telonic (7,9); Tennaplex ✓ (9,11,13); Tepco (1,9,15); Terracom ✓ (13); Texscan ✓ (1,7,9); Townsend ✓ (1,6); Tweed ✓ (1,9); UHF (15); Varian ✓ (2); Wavetek (7)

Satellite Earth Stations

TYPES:

- (1) Transmit/receive
- (2) Receive only
- (3) Transportable

SUPPLIERS:

Alden ✓ (2); Anixter-Mark (1,2,3); Antennas for Comm. ✓ (2,3); Antenna Tech. ✓ (1,2,3); Arvin/Diamond ✓ (2); Automation Techniques ✓ (2); Avantech ✓ (2); Avcom ✓ (2); California Microwave ✓ (1,2,3); Coastcom (1); Comtech ✓ (1,2,3); Dalsat ✓ (3); Dexcel ✓ (2); Drake (2); Electrohome ✓ (1); Ellis Tower ✓ (1); Fort Worth Tower ✓ (2,3); Gabriel (2); Gardiner ✓ (2); GTE Lenkurt ✓ (2); Harris ✓ (1,2,3); Hughes Microwave ✓ (2); LNR (1); M/A-COM ✓ (1,2,3); McMartin ✓ (1,2); Microdyne ✓ (2,3); Microwave General ✓ (2); Modulation Assoc. ✓ (1,2); NEC ✓ (2); Netcom ✓ (2,3); New England Sat. ✓ (3); Pinzone ✓ (1,2); Satcom ✓ (1,2); Ken Schaffer ✓ (2,3); Scientific-Atlanta ✓ (1,2); Wegener ✓ (1); Winegard ✓ (2); Wold ✓ (1,2,3)



And now
a
message
on
Yamaha's new
RM1608
recording
mixer.

Circle 130 on Reader Service Card



RM1608

SPECIFICATIONS

TOTAL HARMONIC DISTORTION (T.H.D.)

Less than 0.1% at +4dB *output, 20Hz to 20kHz (all Faders and controls at nominal)

HUM & NOISE (20Hz to 20kHz) $R_s = 150$ ohms (INPUT GAIN "-60")

- 128dB Equivalent Input Noise (E.I.N.)
- 95dB residual output noise: all Faders down.
- 80dB (84dB S/N) PGM Master volume control at maximum and all CH PGM assign switches off.
- 64dB (68dB S/N) PGM Master volume control at maximum and one CH Fader at nominal level.
- 73dB (77dB S/N) STEREO Master Fader at maximum and all CH STEREO level controls at minimum level.
- 64dB (68dB S/N) STEREO Master Fader at maximum and one CH STEREO level control at nominal level.
- 80dB (70dB S/N) ECHO SEND volume at maximum and all CH ECHO volumes at minimum level.
- 75dB (65dB S/N) ECHO SEND volume at maximum and one CH ECHO volume at nominal level.

CROSSTALK

- 70db at 1kHz: adjacent Input.
- 70db at 1kHz: Input to Output.

MAXIMUM VOLTAGE GAIN (INPUT GAIN "-60")

PGM	74dB: MIC IN to PGM OUT.	ECHO	70dB: MIC IN to ECHO SEND.	
	24dB: TAPE IN to PGM OUT.		C/R	74dB: MIC IN to C/R OUT.
	34dB: ECHO RETURN to PGM OUT.			24dB: 2 TRK IN to C/R OUT.
	14dB: PGM SUB IN to PGM OUT.		STUDIO	74dB: MIC IN to STUDIO OUT.
STEREO	74dB: MIC IN to STEREO OUT.	24dB: 2 TRK IN to STUDIO OUT.		
24dB: TAPE IN to STEREO OUT.				
	34dB: ECHO RETURN to STEREO OUT.			

CHANNEL EQUALIZATION

± 15 dB maximum

HIGH: from 2k to 20kHz PEAKING. MID: from 0.35k to 5kHz PEAKING. LOW: from 50 to 700 Hz PEAKING.

HIGH PASS FILTER -12dB/octave cut off below 80Hz.

OSCILLATOR Switchable sine wave 100Hz, 1kHz, 10Hz

PHANTOM POWER 48V DC is applied to XLR type connector's 2 pin and 3 pin for powering condenser microphone.

DIMENSION (W x H x D) 37-1/2" x 11" x 30-1/4" (953 mm x 279.6 mm x 769 mm)

Hum and Noise are measured with a -6dB octave filter at 12.47kHz: equivalent to a 20 kHz filter with infinite dB octave attenuation.

*0dB is referenced to 0.775V RMS.

• Sensitivity is the lowest level that will produce an output of -10dB (245mV), or the nominal output level when the unit is set to maximum gain.

• All specifications subject to change without notice.

The specs speak for themselves. But they can't tell you how natural, logical and easy the RM1608 is to work. All the controls and switches are logically arranged to help you get the job done quickly and accurately.

And in the tradition of Yamaha's sound reinforcement mixers, the RM1608 sets new standards of reliability as well as ease of operation. For complete information, write: Yamaha International Corporation, P.O. Box 6600, Buena Park, CA 90622. In Canada, Yamaha Canada Music Ltd., 135 Milner Ave., Scarborough, Ont. M1S 3R1.





Microwave

TYPES:

- (1) Intercity
- (2) Portable ENG
- (3) Airborne
- (4) Central receivers

SUPPLIERS:

Broadcast Microwave ✓ (1-4); Cablewave ✓ (1); Commerce Airborne ✓ (3); Datum ✓ (2,3,4); E-N-G ✓ (2); Enstrom ✓ (2,3); GTE Lenkurt ✓ (1); Harris Broadcast ✓ (1-4); Harris Microwave ✓ (1-4); Hughes Microwave ✓ (1); International Microwave (1,2); Loral (1,2,4); M/A-COM ✓ (1-4); Marti ✓ (1-4); MBB Helicopter ✓ (3); Micro Comm. ✓ (2); Moseley ✓ (1); NEC ✓ (2); Nurad ✓ (1-4); Power Pak ✓ (1); RF Technology ✓ (1-4); Systron Donner ✓; Telonic; Terracom ✓ (1,2); Wold ✓ (1,2)

Remote Control Systems

SUPPLIERS:

American Laser ✓; CAT ✓; Channelmatic; Cinema Products ✓; Coastcom; Comark ✓; Engineering Lab; Hallikainen ✓; Harris Broadcast ✓; M/A-COM ✓; Marti ✓; McMartin ✓; Micro Controls ✓; Microdyne ✓; Moseley ✓; Nurad ✓; Power-Optics ✓; QEI ✓; Soll; TFT ✓; Tweed ✓; Vamco

Remote Pickup Equipment

SUPPLIERS:

Artel ✓; Broadcast Microwave ✓; Broadcast Technology ✓; Comrex ✓; Harris Broadcast ✓; M/A-COM ✓; Marti ✓; McMartin ✓; Moseley ✓; Motorola ✓

STLs

TYPES:

- (1) Microwave
- (2) Satellite
- (3) Telco
- (4) Fiberoptic
- (5) Waveguide

SUPPLIERS:

Antennas for Comm. (1,2,3,5); Artel ✓ (4); Avantek ✓ (1); Bayly ✓ (3); Broadcast Microwave ✓ (1); Cablewave (1,5); Dielectric ✓ (5); Gabriel (1,5); GTE Lenkurt ✓ (1,3); Harris Broadcast ✓ (1,2); Harris Microwave ✓ (1); Hughes Microwave ✓ (1); International Microwave (1); Loral (1,3); M/A-COM ✓ (1,4); Micro Controls ✓ (1); Marti ✓ (1); Modulation Sciences ✓; Moseley ✓ (1); Nurad ✓ (1); Power Pak ✓ (1); RE ✓ (4); RF Technology ✓ (1); Scientific-Atlanta ✓ (2); Telemet ✓ (3,4); TEA ✓ (4); Terracom ✓ (1); TFT ✓ (1); Valtec ✓ (4); Wold ✓ (1,2,3)

SCA Equipment

TYPES:

- (1) FM
- (2) TV
- (3) Terminals

SUPPLIERS:

Belar ✓ (1,2); Broadcast Electronics ✓ (1); CRL ✓ (1); Continental Electronics ✓ (1); Emergency Alert (1); E-N-G ✓ (1); Harris Broadcast ✓ (1,2); Johnson ✓ (1,2); Marti ✓ (1,2); McMartin ✓ (1,2,3); Micro Controls ✓ (1,2); Modulation Sciences ✓; Moseley ✓ (1,2); Power Pak ✓ (1); QEI ✓ (1); Singer ✓ (1); TFT ✓ (1,2)



Perfect Timing

CLOCKS AND TIMERS

FROM \$166



TO \$471



(213) 322-2136

142 Sierra Street, El Segundo, CA 90245

Circle 132 on Reader Service Card

BM/E AUGUST, 1983 45



Weather Radar Systems

SUPPLIERS:

Advanced Designs ✓; Alden ✓; Arvin/Diamond ✓; Color-
Graphics ✓; Enterprise ✓; Information Processing; Kavouras ✓;
Satellite Broadcast ✓; Technology Service ✓

Slow Scan Transmitters, Receivers

SUPPLIERS:

Colorado Video ✓; Ken Schaffer ✓; Terracom ✓

Two-Way Radio Communications Transmitters, Receivers

SUPPLIERS:

Bayly ✓; Circuit Devel. ✓; GTE Lenkurt ✓; HME ✓; Marconi ✓;
Marti ✓; McMartin ✓; Motorola ✓; Sonar ✓; Swintek ✓

Antennas

TYPES:

- (1) AM
- (2) FM
- (3) TV HP
- (4) TV CP
- (5) Microwave
- (6) Satellite dish
- (7) Communications
- (8) Antenna tuning units

SUPPLIERS:

Alford; Andrew ✓ (3,5,6,7); Anixter-Mark (5,6,7); Antennas for
Comm. (5,6,7); Antenna Tech. ✓ (5); Barker & Williamson (7);
Blonder-Tongue ✓ (2,3); Bogner ✓ (2-5); Broadcast
Microwave ✓ (5); Cablewave ✓ (5); Cetec Antennas ✓ (2,3,4);
Comark ✓ (2); Continental Electronics ✓ (2,8); CSP ✓ (8);
Elcom Bauer ✓ (8); Gabriel (5,6); Grumman ✓ (8); Harris Broad-
cast ✓ (1-6,8); Harris Satellite ✓ (6); Hughes Microwave ✓ (6);
Johnson ✓ (2); Larcen ✓ (3); LeBlanc & Royle ✓ (1);
M/A-COM ✓ (6); Magnum ✓ (1); Marti ✓ (5,7); McKay Dymek
(1,7); McMartin ✓ (1,2,3,4,6,7,8); Micro Comm. ✓ (2,4,5);
Microdyne ✓ (6); Motorola ✓ (7); Netcom ✓ (6); Fred A.
Nudd ✓ (1); Nurad ✓ (5); Old Dominion (8); Phelps Dodge
(2,7); Polar (3); Prodelin ✓ (5,6); RCA Commercial ✓ (2,3,4); RF
Technology ✓ (5); Satcom ✓ (6); Scala ✓ (1-3,5,7); Scientific-
Atlanta ✓ (2,3,6); Shively ✓ (2,3,4,8); Sitco ✓ (3); SWR ✓ (3);
Telex ✓ (7); Tennaplex ✓ (2,3,4,7); True Time ✓ (6);
Winegard ✓

Transmission Line, Cable, Connectors

TYPES:

- (1) Solid core
- (2) Foam dielectric
- (3) Fiberoptic

SUPPLIERS:

Andrew ✓ (1,2,3); Anixter-Mark (2); Antennas for Comm. (2); Ar-
tel ✓ (3); Brand-Rex ✓ (1,2,3); Cablewave ✓ (2); Daburn ✓
(1,2,3); Gabriel (1,2); Marti ✓ (2); McMartin ✓; Phelps Dodge
(1,2); Prodelin ✓; Scientific-Atlanta ✓ (2); Siecor ✓ (3); SWR ✓
(1); Telemet ✓ (3); Times ✓ (1,3)

Towers

TYPES:

- (1) Towers, masts
- (2) Tower hardware, construction equip.
- (3) Tower lighting

SUPPLIERS:

Advanced industries ✓ (1,2,3); Allied Tower ✓ (1,2,3); Atlas
Tower ✓ (1,2,3); Broadcast Microwave ✓ (1); Copperweld (2);
Deters (1,2); EG&G ✓ (3); Ellis Tower ✓ (1); Flash Tech. ✓ (3);
Fort Worth Tower ✓ (1,2,3); Grasis ✓ (1,3); Hughey & Phillips ✓
(3); Kline (1,2); LeBlanc & Royle ✓ (1,2,3); Magnum ✓ (1,2);
McMartin ✓ (1); Microfect ✓ (1); N-Pro ✓ (1); Fred A. Nudd ✓
(1,2); Allen Osborne (1); Philadelphia Resins ✓ (2); Polites (2);
Racal-Decca ✓ (2,3); Stainless ✓ (1); Swager (1,2,3); Telex ✓
(1,2); TMD ✓ (1); Tri-ex ✓ (1); UNR-Rohn ✓ (1,2,3); Utility Tower
(1,2,3); ZRC (2)



Other RF Equipment

TYPES:

- (1) Program subcarrier
- (2) Carrier current
- (3) Phasing network
- (4) PTV scramblers
- (5) Other

SUPPLIERS:

American Laser ✓ (5); Blonder-Tongue ✓ (4); California Micro-
wave ✓ (4); Coastcom (1); Continental Electronics ✓ (3); CSP ✓
(3); Datum ✓ (5); Digital Video ✓ (4); Dynamcom (4,5); GTE
Lenkurt ✓ (1,5); Harris Broadcast ✓ (3); McMartin ✓ (1,2); Mi-
crowave (1); Kappa (3); LPB ✓ (2); Marti ✓ (1); Micro Comm. ✓
(5); Moseley ✓ (1); Oak ✓ (4); Power Pak ✓ (1); Scientific-
Atlanta ✓ (1); Tepco (1); Winegard ✓ (4); Zenith ✓ (4)

TEST & MEASUREMENT, LOGGING, TIMING

Audio T&M

TYPES:

- (1) Audio test signal generators
- (2) Harmonic distortion meters
- (3) IM meters
- (4) Spectrum analyzers
- (5) sideband analyzers
- (6) Wow & flutter meters
- (7) Other (real time analyzers, etc.)

SUPPLIERS:

Amber ✓ (1-4); Anritsu ✓ (4); Asaca ✓ (1,2); Audisar ✓ (1);
AVAB ✓ (5,6); Bald Mountain ✓ (1); Bird ✓ (1); Bruel & Kjaer ✓
(1-7); Cetec Vega ✓ (1); Conex ✓ (1); Data Precision ✓ (6);
Datatronix ✓ (1); DigiMax (7); Electro Sound (1); Eventide ✓ (4);
Fidelipac ✓ (6); Finntek (1); Frequency Devices ✓ (1);
Glentronix ✓ (5); Global Spec. ✓ (7); Gotham Audio ✓ (6);
Heath (2); Hewlett-Packard ✓ (4,5); HF (1,2); Inovonics ✓ (4);
Ivie ✓ (1,4); Kay ✓ (4); Klark-Teknik ✓ (4); Leader Inst. ✓ (2,6);
Modular Audio ✓ (1); Motorola ✓ (4); NEI ✓ (4); Polarad (4);
Potomac ✓ (1,2,3,6); RE ✓ (2,3,4,6); Ken Schaffer ✓ (4); HH
Scott (4); Sencore (1); Sound Tech ✓ (1-4, 6,7); Spectra Sonics
(1,7); Tektronix ✓ (1-5); Texscan ✓ (4); United Recording ✓ (1);
White ✓ (1); Xedit (6)

RF T&M

TYPES:

- (1) Demodulators
- (2) Modulation monitors
- (3) Antenna monitors
- (4) AM field intensity meters
- (5) FM field intensity meters
- (6) TV field intensity meters
- (7) RF power meters, wattmeters
- (8) RF calorimeters
- (9) Frequency monitors, controllers

“My goal is to find a camera that’s broadcast quality, tough in the field and easy on the budget.”



HITACHI HEARD YOU.

The new Hitachi FP-15 is a rugged, low-cost camera that’s outstanding in the field. Whether you’re shooting news or a documentary.

It’s packed with features normally found on a \$40,000 camera. Yet it sells for under \$6,500.

The FP-15’s 3-tube prism optics with advanced $\frac{2}{3}$ " Saticon tubes shoot bright, sharp, broadcast quality pictures in just about any light or location. And the camera’s aluminum die-cast housing and shock-mount RGB assembly assure high performance and maximum durability under the toughest field conditions.

The FP-15 weighs only 11.2 pounds (excluding lens). It has built-in

corner registration, 550 lines of horizontal resolution and a signal to noise ratio of 54dB.

Other features include: auto white, auto black, auto iris, ABO, a +6 and +12 dB gain switch, and built-in genlock. A full line of accessories is also available, including a 4.5" viewfinder and remote operation unit for studio use.

The Hitachi FP-15 ENG/EFP camera. It’s a winner. Put it on *your* news or production team.

For more information, write or call Hitachi Denshi America, Ltd., Broadcast and Professional Video Divisions, 175 Crossways Park West, Woodbury, NY 11797. (516) 921-7200. Offices also in Atlanta, Chicago, Cincinnati, Dallas, Denver, Los Angeles, Seattle, and Washington, D.C.

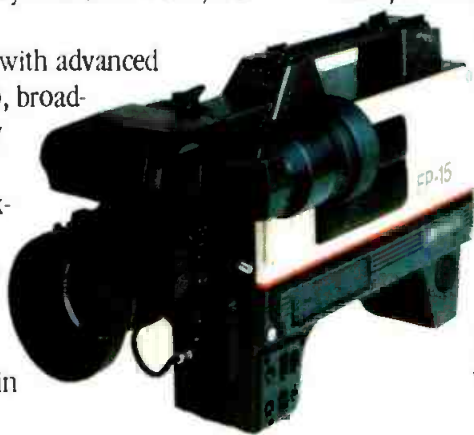

Circle 133 on Reader Service Card

www.americanradiohistory.com



- (10) RF test signal generators
- (11) Impedance bridges
- (12) Phase meters
- (13) Other

SUPPLIERS:

American Laser ✓ (13); Anchor (1); R.B. Annis ✓ (13); Anritsu ✓ (6,7,9); Bald Mountain ✓ (9); Barker & Williamson (7); Belar ✓ (1,9); Bird ✓ (7,8); Boonton (2,7,10,11); Bush & Millimaki ✓ (1); Coaxial Dynamics (3,5,9); Comark ✓ (1); Delta ✓ (2,3,10,11); Di-electric ✓ (7); DigiMax (13); EEG ✓ (1); Electro Impulse ✓ (7,8); John Fluke ✓ (10); Global Spec. ✓ (9,13); Gorman-Redlich ✓ (3,12); Harris Broadcast ✓ (2); Heath (9); Hewlett-Packard ✓ (2,11); Hipotronics ✓ (10); Kappa (13); Kay ✓ (10); Leader Inst. ✓ (6,7,10,11,13); Lectrotech (9); Lenco ✓ (1); LPB ✓ (1); McMartin ✓ (1,2,5,9); Minolta ✓ (13); Keith Monks ✓ (11,12); Motorola ✓ (2,7,9,10); Phasecom (1); Philips T&M ✓ (1,10); Polarad (4,5,6,10); Potomac ✓ (3-6,10,12); QEI ✓ (2); QSI ✓ (1); RE ✓ (2,10); Rohde & Schwarz ✓ (1,5); Sadelco ✓ (6,11,13); Scientific-Atlanta ✓ (1,2,9,10); Sencore (11); Sennheiser ✓ (11); Shively ✓ (7); Sound Tech. ✓ (10); Studer Revox ✓ (1); Systron Donner ✓ (9,10); Tektronix ✓ (1,10,13); Telemet ✓ (1); Telonic (11); Texscan ✓ (11); TFT ✓ (1,2,9); Video Aids ✓ (12); Videotek ✓ (1); Weston ✓ (9); Wide Band ✓ (11,13); World Tower ✓ (1)



Video T&M

TYPES:

- (1) Video test signal generators
- (2) Automatic VITS analyzers

RTW
Peak Meter



Stereo Peak Program Meter
Model 1206

- 101 segment display permits precise peak level metering
- Automatic ON/OFF switching dependent on signal presence
- Auxiliary input for full scale metering of low level inputs

Available exclusively through



auditronics. inc.

3750 Old Getwell Rd.
Memphis, TN 38118, USA
Tel.: (901) 362-1350
Telex: 533356

Circle 134 on Reader Service Card

- (3) Blanking meters, adjusters
- (4) Burst phase meters
- (5) Diff. phase/gain meters
- (6) Video noise meters
- (7) Waveform monitors
- (8) Vectorscopes
- (9) Other

SUPPLIERS:

Amtron ✓ (1); Anritsu ✓ (7); Asaca ✓ (1,2,6); Auburn Instr. (3); AVL Digital ✓ (1); Broadcast Video ✓ (2,3,7,8); Colorado Video ✓ (7); Finntek (1); Fiorentino ✓ (9); Heath (8); Hedco ✓ (9); Hewlett-Packard ✓ (5); Hickock (1); Leader Inst. ✓ (1,7,8); Lectrotech (7,8); Leitch ✓ (1,9); Lenco ✓ (6); Marconi ✓ (3); Multidyne ✓ (1); NTI ✓ (1); Philips T&M ✓ (1,2,7,8); Porta-Pattern ✓ (9); Rohde & Schwarz ✓ (1,2,6); Sencore (1); Tektronix ✓ (1,2,7,8); Telemet ✓ (1); TEA ✓ (1); Ultra Audio ✓ (7,8); Video Aids ✓ (4); Videotek ✓ (7,8); Visual Info. ✓ (1); Wavetek (1); World Video ✓ (3,9)

General T&M

TYPES:

- (1) Oscilloscopes
- (2) Delayed sweep scopes
- (3) Voltmeters
- (4) Multimeters
- (5) dB meters
- (6) Logic analyzers
- (7) Other

SUPPLIERS:

Amber ✓ (5); Anritsu ✓ (3,6,7); Apert-Herzog ✓ (6); Bald Mountain ✓ (5); Boonton (3); Bruel & Kjaer ✓ (3,5); Data Precision ✓ (1,3,4,7); dbx ✓ (5); John Fluke ✓ (3,4,5); Global Spec. ✓ (7); Heath (1,3,5); Hewlett-Packard ✓ (1,3-7); HF (3); Hickock (1,4,6); Image Video ✓ (3); International Instruments ✓ (3,5); ITT ✓ (3); Leader Inst. ✓ (1-5); Marshall Claude (1,3,4,6); Motorola ✓ (1-6); Odetics ✓ (6); Philips T&M ✓ (1,2,6); Practical Tech ✓ (6); Sencore (1,3,5); Systron Donner ✓ (4,5); Tektronix ✓ (1-4,6,7); Telonic (5); Texscan ✓ (1); TM Systems (5); Vidair (4); Wavetek (1); Weston ✓ (3,4,5)

Logging, Monitoring

TYPES:

- (1) Tape-based loggers
- (2) Log printers
- (3) Chart recorders
- (4) Automatic TV monitors
- (5) Automatic radio monitors
- (6) Status, alarm indicators
- (7) Other

SUPPLIERS:

Alden ✓ (3); B&I (6); Bird ✓ (6); Bruel & Kjaer ✓ (3); Delta ✓ (6); Dictaphone ✓ (1); Hallikainen ✓ (2,7); Logitek ✓ (3); Moseley ✓ (2,6); Nagra ✓ (1,3); Neutrik ✓ (3); Pinzone ✓ (6); Potomac ✓ (2,5,6); QSI ✓ (1); Scientific-Atlanta ✓ (6); SoundScriber (1); Stancil ✓ (1); Tektronix ✓ (4); Telex ✓ (1); TFT ✓ (6); Trepac (6); United Recording ✓ (3)

Clocks, Timing

TYPES:

- (1) Digital clocks
- (2) Master, slave clocks
- (3) Timers
- (4) Time distribution
- (5) Other

SUPPLIERS:

Amtel (1-4); Audio Metric ✓ (3); Audio Techniques ✓ (1); BG Engineering (3); Broadcast Aids ✓ (1,3); Channelmatic (1,5); Chrono-Log ✓ (1-4); Datum ✓ (1-5); ESE ✓ (1-4); For-A ✓ (3); Glentronix ✓ (1,2); KB ✓ (1,3); Kitchen (5); Lauderdale (1,3); Leitch ✓ (1,2); McCurdy ✓ (1,2); NES ✓ (1,2,3); Odetics ✓ (1-4); QSI ✓ (3); Radio Systems ✓ (3); RTI ✓ (3); Sharepoint (1,3); Skotel ✓ (5); Standard Elec. ✓ (1-4); Systron Donner ✓ (1,4); Torpey ✓ (1-5); True Time ✓ (3,5); United Media ✓ (4)

The Professionals in Post-Production...

FOR-A COMPLETE DIGITAL TIME BASE CORRECTOR (FA-410) with every function you



need, it's probably the most 'transparent' TBC available! It delivers:

- Greater stability
- Better signal-to-noise ratio for both chrominance and luminance
- Standalone VTR SC operation
- Black burst outputs
- Dropout compensation
- 16 H Window
- Full compatibility with 3/4" and 1/2" VTRs
- Corrections of capstan-servoed or non-servoed VTRs
- Proc Amp functions... plus a Built-in sync generator. It permits simple interface to any switcher.

FOR-A TIMECODE READER WITH VIDEO DISPLAY, the NEW TCR-3500 is a

Timecode Reader + Title Generator + Time/Date Generator + Counter. It provides:

- Full SMPTE and EBU plus User Bit data reading functions with BCD code
- Real-time character display that lets you automatically superimpose timecode readout
- Two timecode memories that let you note any point in the



tape for pushbutton retrieval

- Tape number display
- Drop frame compensation
- Realtime display with battery back-up... plus many more features.



FOR-A COMPLETE COLOR CORRECTOR (CCS-4200), excellent for VTR editing, it corrects both color balance and video signals for variations in scene conditions and camera set-up. Features include:

- Individual RGB Gain and Black Level adjustments
- Very low signal distortion
- Balanced and Differential mode of operation
- Full Proc Amp.

Call your nearest FOR-A Sales Office for a demonstration of these and many other products in our complete line of video broadcast/post-production equipment.

and more!

In addition to these major video components for both Broadcast and Post-Production use, FOR-A offers a comprehensive line of video systems including:

Title Keyers
Video Writers
Timecode Generators

Video Typewriters and Accessory Components :

Multiple Page Memory Units
Wipe Control Unit
Edge Unit
Special Font Generator
Color Control Unit

Sync Pulse Generator
Video Distribution Amplifier
Color Encoder
Automatic Level Generator
Title Generator
Image Correction Systems
Color Synthesizer

FOR-A[®]
INNOVATIONS IN VIDEO

FOR-A CORPORATION OF AMERICA

East Coast: 49 Lexington St., Newton, MA 02165 (617) 244-3223
West Coast: 1680 N. Vine St., Los Angeles, CA 90028 (213) 467-8412

Circle 135 on Reader Service Card



COMPONENTS, HARDWARE

Furniture, Storage

TYPES:

- (1) Studio furniture
- (2) Studio consoles
- (3) Tape storage units
- (4) 19-inch equipment racks

SUPPLIERS:

Allied Broadcast ✓ (1,2); Amco Engineering ✓ (1,2,4); Aristocart ✓ (3); Bally (shelters); Bayly ✓ (4); B-W Lighting ✓ (4); Calzone ✓ (1,4); Emcor ✓ (1,2,4); Enclosure (4); E-N-G ✓ (4); Environmental (4); Fidelipac ✓ (3); GF ✓ (2,4); GKM (4); Graphic Express ✓ (2); Grinnan ✓; Grumman ✓ (4); Harris Broadcast (2); HSC (1,2,4); Marconi ✓ (2,4); Modular Audio ✓ (4); Neumade ✓ (3); Optima ✓ (1-4); Plastic Reel ✓ (3,4); Radio Systems ✓ (1); RTI ✓ (1,3,4); Ruslang ✓ (1-4); Scientific-Atlanta ✓ (4); Stantron ✓ (1,2,4); Storeel ✓ (3); Tweed ✓ (1,2,4); Wallach ✓ (3); Winsted ✓ (1-4)



Wire, Cable, Connectors

TYPES:

- (1) Video cable
- (2) Audio cable
- (3) Lighting, ac cable
- (4) RF cable
- (5) Connectors
- (6) Jackfields, patch panels

SUPPLIERS:

ADC ✓ (5,6); Alpha Wire; AMP ✓ (5); Audio Techniques (2); Audio-Technica ✓ (2); Belar ✓ (1,4); BIW ✓ (1-5); Brand-Rex ✓ (1-5); B-W Lighting ✓ (3,5,6); Cablewave ✓ (4,5); Calvert ✓ (1,2,4); Cambridge (5); Comad ✓ (6); Computer Cable ✓ (2,6); Connectronics ✓ (2,5); Daburn ✓ (1-5); Dynatech ✓ (4,5,6); Electronics Diversified ✓ (5,6); Glentronix ✓ (6); Ideal (3,5); Image Video ✓ (6); Jenel (6); Kings (5,6); Lemo ✓ (5,6); LTM ✓ (3,5); M/A-COM ✓ (4,5); Marconi ✓ (6); Modular Audio ✓ (6); Motorola ✓ (4,5); Neutrik ✓ (5); Olesen ✓ (3,5); Pace ✓; Radio Systems ✓ (6); RCA ✓ (4,5); RMS (1,5); Scientific-Atlanta ✓ (4); Seacor (5); Shively ✓ (4,6); Shure ✓ (2); Spectra Sonics (2); Superior ✓ (5); Switchcraft ✓ (2,5,6); SWR ✓ (4,5); Trompeter ✓ (1,4,5,6); Union Connector ✓ (3,5,6); Vidaire (2,5); Whirlwind ✓ (2,6); Wireworks ✓ (1,2,5,6)

Hum Bucking Coils

SUPPLIERS:

Jenel; North Hills; PTS; V.A.M.P. ✓

RF Gaskets, Inductors

SUPPLIERS:

Calvert ✓; Kappa; Midwest ✓; Surcom

Vacuum Tubes

SUPPLIERS:

Amperex ✓; Calvert ✓; Econco; Freeland ✓; Inmark; RCA ✓; Thomson-CSF ✓; Thor ✓; Vacuum Tube ✓; Varian Eimac ✓; Westinghouse ✓

Solid State Components

SUPPLIERS:

Amperex ✓; Apert-Herzog ✓; Calvert ✓; Fairchild ✓; M/A-COM ✓; Motorola ✓; RCA ✓; Thor ✓

Transformers

SUPPLIERS:

Calvert ✓; Dahl ✓; Hughey & Phillips ✓; Jensen Transformers; Kappa; Microtran; North Hills; Protech; Sescom ✓; Superior ✓; Topaz ✓; TTE ✓; United Recordings ✓; V.A.M.P. ✓

Rectifiers

SUPPLIERS:

Amperex ✓; Calvert ✓; Thor ✓; Varian Eimac ✓

Surge Protectors

SUPPLIERS:

Calvert ✓; Dyma ✓; LEA ✓; MCG ✓; RCA ✓; Siemens ✓; Superior ✓; Thor ✓; Topaz ✓

Quartz Crystals

SUPPLIERS:

Calvert ✓; Motorola ✓; Perrott ✓

Tools

SUPPLIERS:

Ideal; Jensen Tools ✓; M/A-COM ✓; Marshall Claude; Pace ✓

Other

SUPPLIERS:

Grasis ✓; Gruver; Hedco ✓; HSC; Surcom (capacitors)



SERVICES

Equipment Rental

SUPPLIERS:

Adwar ✓; Aphex ✓; Audio Techniques; Audio-Video; Best Audio ✓; Birns & Sawyer ✓; Camera Mart ✓; Center Video; Cetec Antennas ✓; Columbia Video; Digital by Dickinson ✓; Victor Duncan ✓; Dyma ✓; ENG Helicopter ✓; Fantasee; F&B/Ceco; Fitzco ✓; Film/Video Equip. ✓; Frezzolini ✓; General Television ✓; David Green ✓; Image Devices ✓; Landy ✓; Laumic ✓; Leasametric ✓; L. Matthew Miller; Mitsubishi ✓; MPCS ✓; Plastic Reel ✓; Sawyer; Ken Schaffer ✓; Scharff ✓; Solid ✓; John Sullivan ✓; Technisphere ✓; Video Corp. ✓; Westec

Audio Post-Production Facilities

SUPPLIERS:

Best Audio ✓; Compact Video ✓; Continental Recording; Correlli; Firstcom ✓; General Television ✓; Gruver; Kansas; McCurdy ✓; Natl. Video Center ✓; W.A. Palmer ✓; Peters ✓; Richmond Sound ✓; William B. Tanner ✓; Valentino ✓; Westec

Recording Studios

SUPPLIERS:

American Image ✓; Columbia Video; Continental Recording; Eureka; General Television ✓; Gruver; JAM; Kansas; Music Director ✓; Natl. Video Center ✓; W.A. Palmer ✓; Peters; Richmond Sound ✓; United Recording ✓; Valentino ✓

George Fridrich's name shows up on a lot of awards.

Only one name shows up on his lenses—Fujinon.

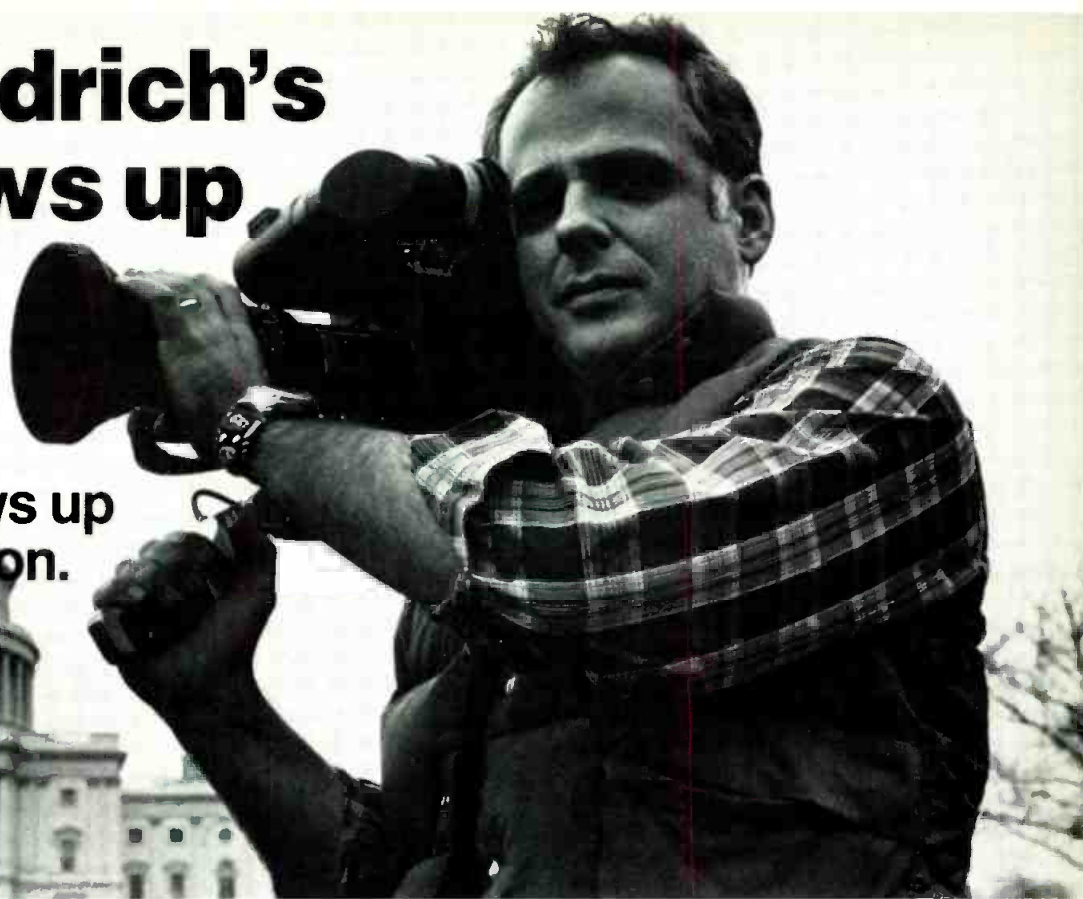

Network news cameraman George Fridrich covers the nation's Capital. Assignments also take him across the country. But wherever he goes, his work speaks with authority. The most prestigious awards confirm it.

The White House News Photographers Association named him "newsfilm photographer of the year" for 1982. (They did the same for 1981 and 1979.) And he received first place awards for spot and feature news in 1982 from the National Press Photographers Association.

Obviously, George Fridrich has his choice of lenses. For years, his choice has been Fujinon, exclusively. Here, in his words, are his reasons:

"Fujinon lenses deliver great performance and reliability. I use two of them, I abuse them and they hold up. They get knocked around and still perform often under the worst conditions. The fact is, you just can't go wrong with any Fujinon lens. On top of that, Fujinon's support and service are fantastic."

George's basic lens is a Fujinon 14X zoom with built-in 2X extender. When he can't get in close, the lens will and because its maximum F1.7 aperture stays flatter, farther, George can still get the brighter, higher contrast picture quality he demands. His second lens is Fujinon's exclusive 3.5x6.5 wide angle zoom. With an MOD under one foot, no assignment is ever missed because of tight quarters.

Incidentally, although George didn't receive the White House News Photographers' award for 1980, Pete Hakel (WJLA, Washington) did. He won with Fujinon, too. It's not a coincidence. According to Pete, "90% of the ENG work in D.C. is Fujinon."

Before you make any ENG/EFP lens decision, see how much more you get with Fujinon.

Fujinon provides it all—performance, quality, reliability and service. And to make it even better, Fujinon is also the value leader. For all the facts and figures to prove it, talk to your Fujinon representative or contact:

Introducing FUJINON'S third generation ENG lens...

THE NEW "WEATHERIZED" A14x9ERM

Fast, light and compact—F1.7 speed, weighs only 1.48kg
Wider angle, smoother zooms—9mm coverage, more precise servo control
Built-in 2X extender
Macro and adjustable back focus

- Servo zoom, auto iris standard
- Wide and tele converters optional
- Full range of studio conversion accessories including Fujinon's microprocessor shot box



The tradition of innovation continues.

Fujinon Inc.
2 White Plains Road
Roseland, New York 10583
(4) 472-9800
fax: 131642

Fujinon Inc.
2101 Midway, Suite 350
Carrollton, Texas 75006
(214) 385-8902

West Coast Division
Fuji Optical Systems, Inc.
118 Savarona Way
Carson, California 90746
(213) 532-2861 Telex: 194978



Circle 136 on Reader Service Card

When **YOU** want
NICKEL CADMIUM

PE 52

Lighting or
Camera

dual output belt



28.8 volt 4 AH
or
14.4 volt 8 AH
in one unit

Versatile • Rugged • Economical

YOU want

PERROTT

a name you can depend on

7201 Lee Highway Falls Church, Va 22046 (703) 532-0700

Circle 137 on Reader Service Card

Telemetry Problems?

Many subcarrier and telco telemetry circuits are shakey, making telemetry return the weakest link in broadcasting. The Marti TSL-15 is solving these problems.



TSL-15

This link consists of a 15 watt type accepted transmitter, a narrow band receiver and Yagi Antennas designed for 450-456 MHz. group P channels. This system will provide continuous-duty operation, and can handle data and voice in a 20Hz.-3000Hz. band. Test meters are provided on both transmitter and receiver. Automatic station identification is available and external DC operation is provided for.

MARTI **MARTI Electronics, Inc.**
1501 N. Main • P.O. Box 661
Cleburne, Texas 76031
(817) 645-9163 • Telex 794 835

Circle 138 on Reader Service Card



Video Post-Production Facilities

SUPPLIERS:

AF Assoc. ✓; A&G Prods.; Allied Film Lab ✓; All Mobile Video ✓; Altatec ✓; American Video Factory ✓; Astro Video; Bay Area Mobiletape; Bullet; Carleton ✓; Carob ✓; CCR ✓; Center City; Center Video; Century III; CFI; Channel One ✓; Chicago Video ✓; Chris Craft ✓; Chronicle ✓; Cinetape ✓; Cine-tronics ✓; Color Film ✓; Columbia Video; Compact Video ✓; Creative Technology ✓; Devlin ✓; Digital Video Productions ✓; Duart ✓; Dudkowski-Lynch ✓; Editel ✓; Electronic Field Pro- ductions ✓; ESPN ✓; Eureka ✓; Excalibur Video; Fax ✓; First Comm.; Florida Prod. ✓; GBH ✓; General Television ✓; Golden West; Hawaii ✓; HBO ✓; Horizontal ✓; Image Resources ✓; Im- age Transform ✓; Interface Video; International Production ✓; Jefferson Productions; Jones; J.S.L. ✓; Kansas; Kartes ✓; KQED ✓; KTVY; KVIE ✓; Line One ✓; Louisville; LRP ✓; Lodes/ Peterson ✓; Matrix ✓; Metro Tape; Mobile Video Prods.; Mobile Video Services ✓; MPCs ✓; MTI; Multivision ✓; Natl. Video Cen- ter ✓; Natl. Video Inds. ✓; NET; Nexus ✓; Niles ✓; North Ameri- can; Northeast Prods. ✓; Northwest Prods.; Northwest Teleprod.; One Pass ✓; Opryland; Optimus; Pacific Coast ✓; Pacific Video; W.A. Palmer ✓; Phase Two; Phoenix; Polycorn; Post Group ✓; Prime Time; Producers Color; Producers Video; Professional Vid- eo ✓; RCA American ✓; Roscor ✓; Scene Three ✓; Skaggs ✓; South Coast ✓; Southwest; Starfax; John Sullivan ✓; Sundance; Sunrise Canyon; Tapepower ✓; Technisphere ✓; Tele-Color ✓; Tele-Image ✓; Telemation ✓; Teleprompter; Teletronics ✓; TV Assoc. ✓; Third Coast ✓; Today Video ✓; TPC ✓; Trans- American; Tritronics; UAB; UMDNJ ✓; Unitel ✓; Versatile Video ✓; Video Central; Videocom; Video Corp. ✓; Video Im- ages; Video Post ✓; Videosmith ✓; Video Tape ✓; Video Transi- tions; Video West ✓; Western Video; WGN ✓; Wickerworks; Windsor ✓; WKYT ✓; WPHL ✓; WXXI ✓; Yes ✓; Arthur Young ✓



Teleproduction Facilities

SUPPLIERS:

Airfax; Altatec ✓; American Image ✓; American Video Factory ✓; Bullet; Burbank Studios ✓; Carleton ✓; Celestial Mechanix; Center City; Century III; Channel One ✓; Chicago Vid- eo ✓; Chris Craft ✓; Chronicle ✓; Cinema Video; Cinetape ✓; Cine-tronics ✓; Compact Video ✓; Computer Image; Columbia Video; Creative Technology ✓; Devlin ✓; Digital Video Produc- tions ✓; Docuvid ✓; Dudkowski-Lynch ✓; ESPN ✓; Eureka ✓; Excalibur Video; Fantasee; Fax ✓; General Television ✓; Hawaii ✓; HBO ✓; Image Resources ✓; Interface Video; Inter- national Production ✓; Jefferson Productions; Jones; Kartes ✓; KQED ✓; KTVY; KVIE ✓; Line One ✓; Lodes/ Peterson ✓; Louisville; LRP ✓; Matrix ✓; Metro Tape; Mobile Video Prods.; Mobile Video Services ✓; MTI; Natl. Video Center ✓; Natl. Video Inds. ✓; NET; Niles ✓; North American; Northwest Comm.; Northwest Teleprod.; One Pass ✓; Opryland; Optimus; Pacific Coast ✓; Pacific Video; Phoenix; Polycorn; Pro- ducers Color; Producers Video; Professional Video ✓; Pyramid ✓; Scene Three ✓; Skaggs ✓; South Coast ✓; South- west; John Sullivan ✓; Sundance; Sunrise Canyon; Tapepower ✓; Tele-Color ✓; Tele-Image ✓; Telemation ✓; Teleprompter; Teletronics ✓; TV Assoc. ✓; Third Coast ✓; To- day Video ✓; TPC ✓; Trans-American; Tritronics; UAB; UMDNJ ✓; Unitel ✓; Versatile Video ✓; Video Central; Video- com; Video Corp. ✓; Video Images; Videosmith ✓; Video West ✓; Western Video; WGN ✓; Wickerworks; Windsor ✓; WKYT; WPHL ✓; WXXI; Yes ✓

Mobile Production Facilities

SUPPLIERS:

A&G Prods.; Airfax; All Mobile Video ✓; American Video Factory ✓; AVT ✓; Bay Area Mobiletape; Carleton ✓; CCR ✓; Center City; Channel One ✓; Chicago Video ✓; Chronicle ✓;

The Comark "S" Series

We just made every other UHF transmitter obsolete.

Broadcast engineers and managers agree. Without a doubt, Comark's new "S" Series UHF television transmitters—from 10kW through 220kW—represent a world class product. Integrating high efficiency, reliability and low cost, each model incorporates state-of-the-art technology to achieve a unique combination of unparalleled features:

- Broadband (no tuning), high power, field proven, exciter system featuring dual channel (redundant) operation as well as Comark's CM-100S Broadcast Modulator with IF S.A.W. filter.
- External cavity, full-band, klystron power amplifiers, combining highest efficiency and compact size.
- Space efficient, mechanical and electrical layouts, fully engineered for maximum EMI/RFI isolation and overall operator convenience.

- Fiber optic telemetry for all floating high voltage metering functions, incorporated into a complete latched fault and status display system.
- Clean, fully isolated, high voltage compartments, with double-filtered air cooling and front access. (No exposed high voltage in klystron areas.)

All Comark "S" Series models are available with advanced system options, including beam current pulsers, motorized RF switching systems, E.D. and ICPM correction systems, and the services of Comark's 24-hour field operations group.

Contact Comark's Sales Office for detailed specifications and further information.



10kW/30kW/55kW
model shown

COMARK

Engineering and Sales Offices
Rt. 309 and Advance Lane
Coimar, PA 18915
(215) 822-0777
Telex: 846075

International Headquarters
Rt. 57, Feeding Hills Road
Southwick, MA 01077
(413) 569-5939

Circle 139 on Reader Service Card



Compact Video ✓; Creative Technology ✓; CRT ✓; Devlin ✓; Digital Video Productions ✓; Docuvid ✓; Electronic Field Productions ✓; ESPN ✓; Eureka ✓; Excalibur Video; Fax ✓; First Comm; Florida Prod. ✓; GBH ✓; Golden West; Hawaii ✓; Image Resources ✓; Jefferson Productions; Jones; Kartes ✓; KQED ✓; KTVY; KVIE ✓; Louisville; LRP ✓; Matrix ✓; Mobile Tech.; Mobile Video Prods.; Mobile Video Services ✓; MTI; Multivision ✓; National ✓; NET; Niles ✓; North American; Northeast ✓; Northwest Comm.; Northwest Teleprod.; One Pass ✓; Opryland; Pacific Video; Phoenix; Polycom; Producers Color; Professional Video ✓; Scene Three ✓; Skaggs ✓; Southwest; Starfax; Sullivan ✓; Sundance; Sunrise Canyon; Tapepower ✓; TBS ✓; Tele-Color ✓; Tele-Image; Telemation ✓; Teleprompter; Teletronics ✓; TV Assoc. ✓; Third Coast ✓; TPC ✓; Trans-American; Tritronics; TRI ✓; UAB; Unitel ✓; Versatile Video ✓; Vidcom ✓; Video Central; Videocom; Video Images; Video One; Videosmith ✓; Video West ✓; WGN ✓; Windsor ✓; WKYT; WPHL ✓; WXXI; Yes ✓

Facility Design & Engineering

SUPPLIERS:

American Television; Audio Techniques; AF Assoc. ✓; Broadcast Microwave ✓; Broadcast Systems; R.W. Burden Assoc.; California Microwave ✓; Central Dynamics ✓; Columbia Video; Comark ✓; Control Tech.; Dalsat ✓; Delcom; Dynacom; EMCEE ✓; First Comm.; Florida Prod. ✓; GBH ✓; General Television ✓; Generic; Golden West; Graham-Patten ✓; Grinnan ✓; Grumman ✓; Harris Satellite ✓; Hughes Helicopters ✓; Jamieson ✓; Jenel; Kavco ✓; Kitchen; Landy ✓; Larcen ✓; Lerro ✓; Lines; Logitek ✓; Long; Midwest ✓; Neve ✓; N-Z Video ✓; Old Dominion; Peirce-Phelps ✓; Radio Systems ✓; RCA ✓; Real World ✓; Rees ✓; Roscor ✓; Rosner ✓; Shook ✓; Soll; Tele-Measurements ✓; Video Corp. ✓; Westlake ✓

Engineering Consultants

SUPPLIERS:

Advanced Designs ✓; American Image ✓; American Television; Broadcast Technology Consultants ✓; R.W. Burden Assoc.; California Microwave ✓; Candex Pacific; Comark ✓; Commerce Airborne ✓; Compucon ✓; Comsearch ✓; Control Tech.; Dalsat ✓; Delcom; Dralke-Chenault ✓; Dubner ✓; East Coast; Fiorentino ✓; Fitzco ✓; Frezzolini ✓; General Television ✓; Grinnan ✓; Harris Broadcast ✓; HSC; Jamieson ✓; Jenel; E.M. Johnson; Kappa; Kavco ✓; Kitchen; Landy ✓; Fred A. Nudd ✓; Professional Prods. ✓; QSI ✓; Radiotechniques; Real World ✓; Rees ✓; Rosner ✓; Soll; Spectrum Planning ✓; Westec; Wold ✓

Studio, Set Design

SUPPLIERS:

Arben ✓; B-W Lighting ✓; Center Video; Columbia Video; East Coast; Fantasee; Fiorentino ✓; Graphic Express ✓; Grosh ✓; Jamieson ✓; LTM ✓; McCurdy ✓; Milan ✓; MPCS ✓; Rees ✓; Rosco ✓; Shook ✓; Tele-Measurements ✓; Television Engineering ✓

Financial Consulting

SUPPLIERS

Generic; Rees ✓; Television Engineering ✓

Earth Station Site Selection

SUPPLIERS:

California Microwave ✓; Compucon ✓; Comsearch; General Television ✓; Harris Broadcast ✓; Kitchen; Netcom ✓; New England Satellite ✓; Radiotechniques; Rees ✓; Ken Schaffer ✓; Spectrum Planning ✓; Wold ✓

Mobile Vehicle Construction

SUPPLIERS:

AF Assoc. ✓; Audio-Video; Bell Helicopter ✓; Central Dynamics ✓; Commerce Airborne ✓; Delcom; Dyma ✓; E-N-G ✓; General Television ✓; Gerstenslager ✓; Gray Comm. ✓; Grinnan ✓; Grumman ✓; Harris Broadcast ✓; HSC; Hughes Helicopters ✓; Jenel; Kavco ✓; Landy ✓; Lerro ✓; Lines; MBB Helicopter ✓; Midwest ✓; N-Z Video ✓; Peirce-Phelps ✓; RCA Commercial ✓; Real World ✓; Roscor ✓; Rosner ✓; Shook ✓; Tele-Measurements ✓; Television Engineering ✓; Wolf ✓



Film Laboratories

SUPPLIERS:

Allied Film Lab ✓; Image Transform ✓; W.A. Palmer ✓

Weather Information

SUPPLIERS:

Advanced Designs ✓; ColorGraphics ✓; Kavouras ✓; W.A. Palmer ✓; Satellite Broadcast ✓; Texas Elect. ✓; WSI ✓

Music Libraries

SUPPLIERS:

American Image ✓; Toby Arnold ✓; Conner; Continental Recording; De Wolfe ✓; Firstcom ✓; Gruver; JAM; KalaMusic ✓; Live Sound; Music Director ✓; Network ✓; Soper ✓; William B. Tanner ✓; Valentino ✓

Satellite Time Brokers

SUPPLIERS:

Compact Video ✓; Netcom ✓; Wold ✓

Syndicated Radio Programming

SUPPLIERS:

American Image ✓; Toby Arnold; Bonneville ✓; BPI; Cavox ✓; Concept; Drake-Chenault ✓; Gruver; KalaMusic ✓; Live Sound; Master; Music Director ✓; Musicworks ✓; Peters ✓; Radio Arts; Real Radio ✓; RPM; UPI ✓; WSI ✓



Other

SUPPLIERS:

Compact Video ✓; Comsearch; Conner; Continental Recording; Convergence ✓; Cross; Enstrom; Fotokem; Generic; Graphic Express ✓; Grosh ✓; Gruver; Image Transform ✓; JAM; Jamieson ✓; Kansas; Landy ✓; Mead Data ✓; PTS; Radiotechniques; RCA American ✓; Rees ✓



the trendsetters

Unquestionably the industry's standard of excellence
in broadcast equipment

Our TOMCAT cartridge recorders/reproducers
and BMX series of broadcast consoles
deliver trendsetting on-line performance
in broadcasting systems world-
wide, from Boston to L.A.,
Australia to Great Britain.

TOMCAT: simply the world's finest. Innovative design assures superb sound quality, reliability, and low noise operation.

BMX, Series II: the ultimate in high performance mixing consoles.

Call or write today for free information on our complete line of equipment.



PACIFIC RECORDERS & ENGINEERING CORPORATION

2070 Las Palmas Drive - Carlsbad, CA 92008 - 619-438-3911 - Telex: 181777

Circle 140 on Reader Service Card



**THIS IS WHERE
STICTION
PROBLEMS
BEGIN.**

It takes a very tough tape to withstand edit after edit through today's VTR equipment and still deliver a crisp, clean playback image.

And tough is exactly what new Scotch® 480 one-inch video tape is.

A special coating formulation on Scotch 480

means you no longer have to worry about problems like stiction.

In fact, during computer editing, 3M lab tests have shown 480 is capable of delivering over 1,000 edits from the same preroll point, with no significant reduction in playback quality.

®Scotch® is a registered trademark of 3M. © 3M, 1983.

Scotch®

480

**NEW
SCOTCH® 480
IS WHERE
THEY END.**

And in today's tough video production environment, that kind of durability can mean a lot.

Scotch 480 is further proof of why 3M is the leader in professional use video tape. And why we sell more one-inch tape for professional use than all other

manufacturers put together.

For a free brochure on new Scotch 480 call 1-800-328-1684 (1-800-792-1072 in Minnesota). And find out more about the tape that's as tough as today's editing equipment.

Magnetic Audio/Video Products Division/3M.



**NEW
SCOTCH 480
1" VIDEO TAPE.
LASER TESTED FOR
CONSISTENCY.**

3M hears you...

3M

INDUSTRY STANDARD CHAPTER II

The New Otari 1/4" Two Channel 5050B-II

The best selling professional two track audio recorder has finally been improved. We've added the refinements you asked for: The inputs and outputs of the new B-II are transformerless, balanced. The elapsed time indicator is a real-time hours/minutes/seconds L.E.D. display—tape accurate at all speeds. The built-in oscillator provides both 1kHz and 10kHz calibration tones. And we added a low frequency adjustment to the reproduce equalizers.

Behind the clean, new look of the B-II are the same features, performance and reliability you expect from our famous 5050B. We didn't change the rugged quarter-inch thick deckplate or the cast aluminum frame. We kept the switch selectable NAB/IEC equalization, +4dBm/-10dBv output levels, half-track and quarter-track playback heads and three standard reference fluxivity levels. And, of course, the B-II still features three tape speeds, XL type connectors, front panel record equalization and bias adjustments, variable speed, "dump edit" function, and an integral splicing block.

The 5050B-II has been engineered like no other tape machine in the world. When you check out the specifications you'll know why we say it's the best \$5,000.00 tape recorder available for under \$2,500.00. When you work with it, you'll know that we've just raised the industry standard.

OTARI Technology You Can Touch.

Otari Corporation, 2 Davis Drive, Belmont, CA 94002
Tel: (415) 592-8311 Telex: 910-376-4890

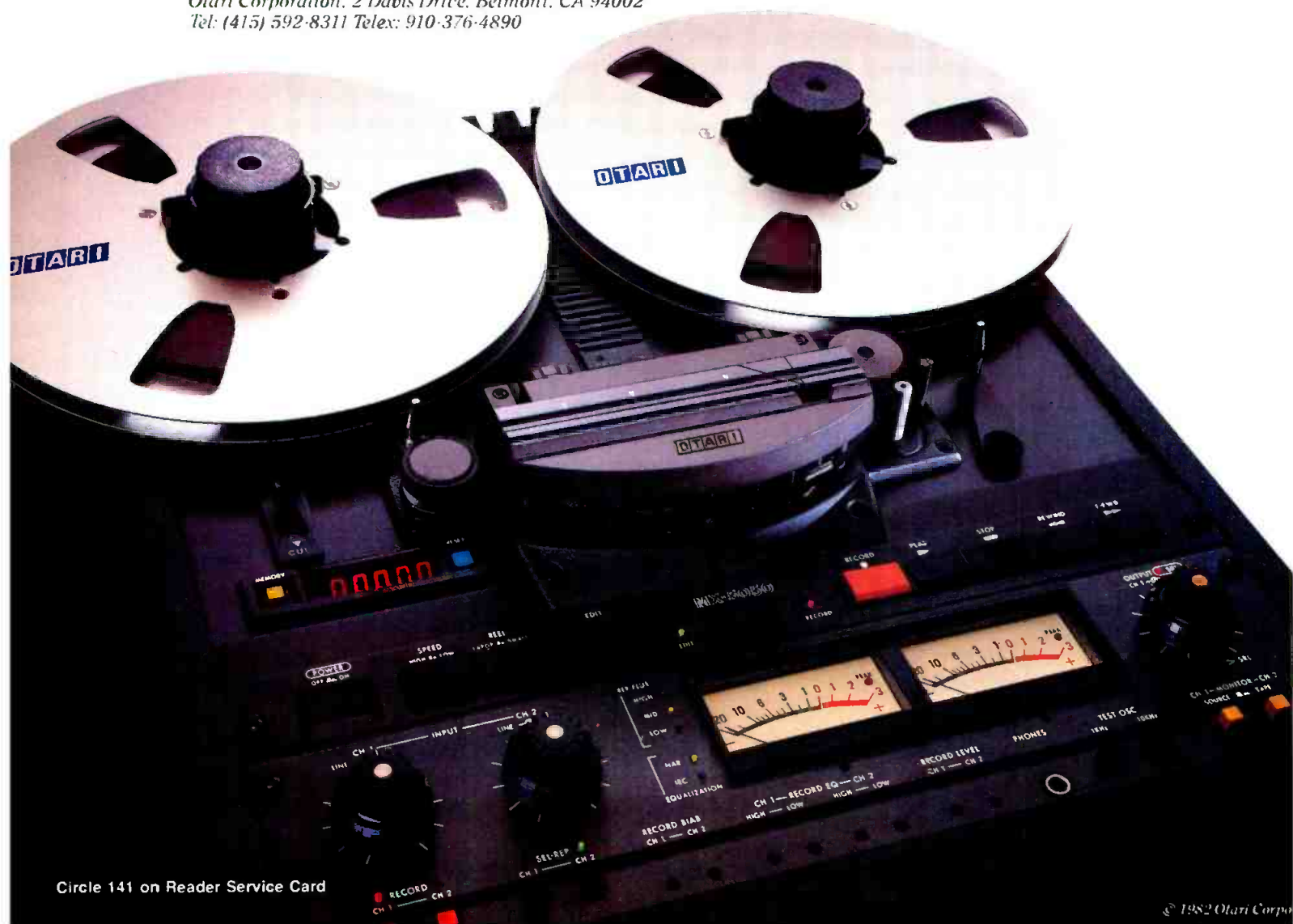

LISTING OF MANUFACTURERS ✓ MEANS IT'S VERIFIED

ABEKAS ✓

319 Lincoln Centre Dr., Foster City, CA 94404
415 571-1711
Electronic still stores.
[See ad on pg. 127](#)
Refer to Reps/Distributors section

ACCURATE SOUND CORP. ✓

3515 Edison Way, Menlo Park, CA 94025
415 365-2843
High-speed audio tape duplicators.

ACOUSTIC RESEARCH ✓

10 American Dr., Norwood, MA 02062
617 769-4200
Monitor speakers.

ACRODYNE INDUSTRIES ✓

516 Township Line Rd., Blue Bell, PA 19422
800 523-2596/215 542-7000
UHF, VHF & LPTV transmitters & translators.

PAUL ADAMS & ASSOCIATES ✓

4090 Youngfield St., Wheat Ridge, CO 80033
303 422-1166
Broadcast business automation hardware & software (Nidus) including traffic, billing, accounts receivable, accounts payable, payroll, general ledger, word processing & music scheduling.

ADAMS-SMITH ✓

34 Tower St., Hudson, MA 01749
617 562-3801
SMPTE time code readers, generators & synchronizers.
[See ad on pg. 120](#)
Refer to Reps/Distributors section
Field Offices:
CA 213-388-8218
NY 516-352-2341

ADC MAGNETIC CONTROLS CO. ✓

4900 W. 78 St., Minneapolis, MN 55435
612 835-6800
Audio patch panels; video jackfields.

ADDA CORP. ✓

130 Knowles Dr., Los Gatos, CA 95030
408 379-1500
Digital still stores; video compressor/positioners; TBCs, frame synchronizers, framestores, TBC/framestores.

ADM TECHNOLOGY, INC. ✓

1626 E. Big Beaver Rd., Troy, MI 48084

313 524-2100

Mono, stereo, audio for TV audio studio consoles; audio DAs, preamps & line amps; PPM meters; audio patch bays; equalizers, noise suppressors; limiter/compressors; deessers; sound effects filters.
[See ad on Cover 2](#)

Field Offices:

CA Ronald Webb, 11 Adak Ct., Walnut Creek 94596 415 945-0181
MI Richard Fisher, 1626 East Big Beaver Rd., Troy 48084 313 524-2100
TX Gordon Peters, P.O. Box 912, Arlington 76010 817 467-2990

ADVANCED DESIGNS CORP. ✓

Box 1907, Bloomington, IN 47402
812 333-1922
Weather radar systems; engineering consultant.

ADVANCE INDUSTRIES, INC. ✓

2301 Bridgeport Dr., Sioux City, IA 51102
712 252-4101
Antenna towers, tower hardware & lighting, equipment shelters.

ADVANCED MUSIC SYSTEMS (AMS) ✓

Harris Sound Svces., 7138 Santa Monica Blvd., Hollywood, CA 90046
213 369-3500
Digital audio special effects, digital delay & reverb, analog special effects & reverb, audio/video sync delay, time compression/expansion.

ADVANCING TECHNOLOGY CORP. ✓

27106 46 Ave. S., Kent, WA 98032
206 854-1004
ALC & AGC amps, AM & FM compressor/limiters; VU & PPM meters; phono preamps with CX noise reduction; equalizer with DNR noise reduction; multiband processor.

ADWAR VIDEO CORP. ✓

335 W. 35 St., New York, NY 10001
212 947-4040/800 344-1414
NTSC encoder for Apple computer. Equipment rental service.

AF ASSOCIATES, INC. ✓

100 Stonehurst Ct., Northvale, NJ 07647
201 767-1000
Marconi one-inch C VTRs, VTR rebuilding; Marconi CCD telecine; mobile van construc-

tion, facility turnkey installation; production equipment rentals; color framer editing aid device; standards converter, camera remote control panels; blanking analyzer; standards conversion & video duplication services.
[See ad on pgs. 32, 150](#)

Field Office:

CA 1438 North Gower Street, Box 50, Hollywood 90028 213-466-5066

A&G PRODUCTIONS

1660 Hotel Circle N., Ste. 107, San Diego, CA 92108
714 291-7031
Mobile teleproduction facility; video post-production facility.

AGFA-GEVAERT, INC. ✓

275 North St., Teterboro, NJ 07608
201 288-4100
Open-reel & bulk cassette audio tape; 3/4- & half-inch videocassettes; bulk/duplicator videocassettes.

AIRFAX VIDEO

211 E. Grand, Chicago, IL 60611
312 836-0211
Studio & mobile teleproduction facilities.

AKG ACOUSTICS ✓

601 Milner Ave., Toronto, Ont. M1B 1M8, Canada
416 292-5161
Time delay audio cart player/recorders; phono cartridges; digital delay & reverb, analog special effects & reverb; headphones; dynamic, electret/condenser, shotgun, lavalier, modular & capsule mics; mic stands, booms, dollies.

PETER ALBRECHT CORP. ✓

325 E. Chicago St., Milwaukee, WI 53202
414 272-2811
Motorized rigging & controls for TV studio lighting & scenery systems.

ALDEN ELECTRONICS, INC. ✓

Washington St., Westboro, MA 01581
617 366-8851
Weather chart recorders; weather satellite earth station.

ALEXANDER MFG. CO. ✓

1511 S. Garfield Pl., Mason City, IA 50401
515 423-8955
Nicad batteries, chargers.

ALFORD MFG. CO. ✓

15 Sixth Rd., Woburn, MA 01801

Manufacturers

617 935-8611
RF diplexers & antennas.

ALLEN AVIONICS, INC. ✓
224 E. 2 St., Box 350, Mineola, NY 11501
516 248-8080
Video delay lines, filters; signal & cable equalizers.
[See ad on pg. 156](#)

ALLIED BROADCAST EQUIPMENT ✓
635 So. E. St., Richmond, IN 47374
317 962-8596
Audio DAs, preamps; studio furniture & cabinets.

ALLIED FILM LABORATORY & VIDEO SVCS. ✓
7375 Woodward Ave., Detroit, MI 48202
313 871-2222
Film-to-tape transfers; videotape duplication services; video post-production facility; film developing.

ALLIED TOWER CO., INC. ✓
12450 Old Galveston Rd., Webster, TX 77598
713 486-7691
Towers & masts; tower hardware, construction equipment, lighting.

ALL MOBILE VIDEO, INC. ✓
630 Ninth Ave., New York, NY 10036
212 757-8919
Equipment rental services, including mobile units; mobile production & post-production facility.

ALLSOP, INC. ✓
4201 Meridian, Bellingham, WA 98226
206 734-9090
Audio tape, cassette cleaners; video head cleaners; record cleaners.

ALPHA AUDIO ✓
2049 W. Broad St., Richmond, VA 23220
804 358-3852
Sonex soundproofing material.
[See ad on pg. 66](#)

ALPHA WIRE CORP. ✓
711 Lidgerwood Ave., Box 711, Elizabeth, NJ 07207
201 925-8000
Wire & cable; cable connectors; tubing.

ALTATEC ✓
7124 Dixie Dr., Austin, TX 78744
512 282-5355
Teleproduction & video post-production facilities.

ALTEC LANSING ✓
1515 Manchester Ave., Anaheim, CA 92803
714 774-2900
Graphic equalizers; monitor speakers; dynamic, electret/condenser, lavalier mics; audio preamps, line amps, monitor & power amps.

AMBER ELECTRO DESIGN, INC. ✓
4810 Jean Talon W., Montreal, Que. H4P 2N5, Canada
514 735-4105

Audio test signal generators, harmonic distortion meters, IM meters, spectrum analyzers; dB meters.

[See ad on pg. 78](#)
Field Offices:
CA Amber Electro Designs, 14125 Capri Dr., Los Gatos 95030 . . . 408-378-3501
IN Pro Marketing Systems, 9628 Day Drive, Indianapolis 46280 317-846-9591
NJ Shea Sales, 552 Prospect St., Maplewood 07040 201-762-2382
PA Technical Instruments Sales, 914 E. Willow Grove Ave., Philadelphia 19118 215-836-2222
UT Partridge Electronic Sales P.O. Box 21205 Salt Lake City 84121 801-272-3131

AMCO ENGINEERING CO. ✓
3801 N. Rose St., Schiller Park, IL 60176
312 671-6670
Studio furniture, consoles, 19-inch equipment racks, desks.

AMEK CONSOLE, INC. (USA) ✓
11540 Ventura Blvd., Studio City, CA 91406
213 704-7528
Audio recording consoles (Amek, Total Audio Concepts, Star Sound Dynamix).

AMERICAN DATA CORP. ✓
See Central Dynamics

AMERICAN IMAGE PRODUCTIONS, INC. ✓
Box 23355, Nashville, TN 37202
800 251-2058
Syndicated radio programming; music library; recording studio; broadcast consulting; TV production.

AMERICAN LASER SYSTEMS, INC. ✓
106 James Fowler Rd., Goleta, CA 93117
805 967-0423
Remote control systems; infrared TV transmission system; wideband current probe.

AMERICAN TELEVISION SYSTEMS ✓
799 E. Aurora Rd., Macedonia, OH 44056
216 418-0000
Engineering contractor; equipment distributor; design & construction of private cable systems & local area networks.

AMERICAN VIDEO FACTORY, INC. ✓
4150 Glencoe Ave., Marina Del Rey, CA 90291
213 823-8622
Studio & mobile teleproduction facilities; video post-production facility.

AMILON CORP. ✓
49-12 30 Ave., Woodside, NY 11377
212 274-1794
Audio cassette transports.

AMP SPECIAL INDUSTRIES ✓
440 Sweedsford Rd., Berwyn, PA 19482
215 647-1000
BNC connectors; connectors for video equipment.

AMPEREX ELECTRONIC CORP. ✓
Providence Pike, Slatersville, RI 02876
401 762-3800
Camera pickup tubes; RF power tubes; vacuum tubes, solid state components, rectifiers; deflection assemblies; power tetrodes & circulators.
[See ad on pg. 121](#)
Refer to Reps/Distributors section
Field Offices:
CA Ed Marchner, Ste. 115, Santa Clara 95050 408 249-1134
CO Ron Barnes, 3110 S. Wadsworth, Denver 80227 303 989-7310
GA Lee Knowell, 3731 N. Crest Rd., Atlanta 30340 404 458-2519
IL Greg Smith, 360 Beinoris Dr., Wood Dale 60191 312 860-7373
TX 13773 N. Central Exy., Dallas 75243 214 231-3481

AMPEX CORP. ✓
401 Broadway, Redwood City, CA 94063
415 367-2011
Portable, studio & multitrack ATRs; replacement & rebuilt audio heads. Studio, ENG/EFP, single-piece cameras. Quad & one-inch C VTRs; video cart automation systems; replacement & rebuilt video heads; VTR rebuilding service; video head cleaners & degaussers; VTR slow-mo controller. Digital still stores. Large, microprocessor-controlled & compact production switchers; post-production switchers; digital effects processors; manual & automated master control switchers. Editor/controllers & multi-source editors; SMPTE time code generators, readers; TBCs.
[See ad on pg. 79](#)

Field Offices:
CA Collin Shaw, 10435 N. Tantau Ave., Cupertino 95014 408 255-4800
Don Carlsen, 500 Rodier Dr., Glendale 91201 213 240-5000
GA Paul Hansil, 3135 Chestnut, Suite 101, Atlanta 30340 404 451-7112
IL Mike d'Amore, 719 W. Algonquin Rd., Arlington Heights 60005 312 593-6000
KY Dick Coomes, 7509 Stonebrook Dr., Louisville 40291 502 239-6111
MD Frank Rush, 10215 Fernwood Rd., Bethesda 20034 301 530-8800
NJ Bob Natwick, 5 Pearl Ct., Allendale Ind. Pk., Allendale 07401 201 825-9600
OH Chuck Wright, 4130 Linden Ave., Dayton 45432 513 254-6101
TX Frank Nault, 3353 Earhart Dr., Carrollton 75006 214 960-1162
UT Dave Clayton, 2880 S. Main St., Suite 111, Salt Lake City 84115 801 487-8181
WA Dick Carroll, 628 Industry Dr., Tuckwila 98188 206 575-0156



2500TH CELEBRATION SALE

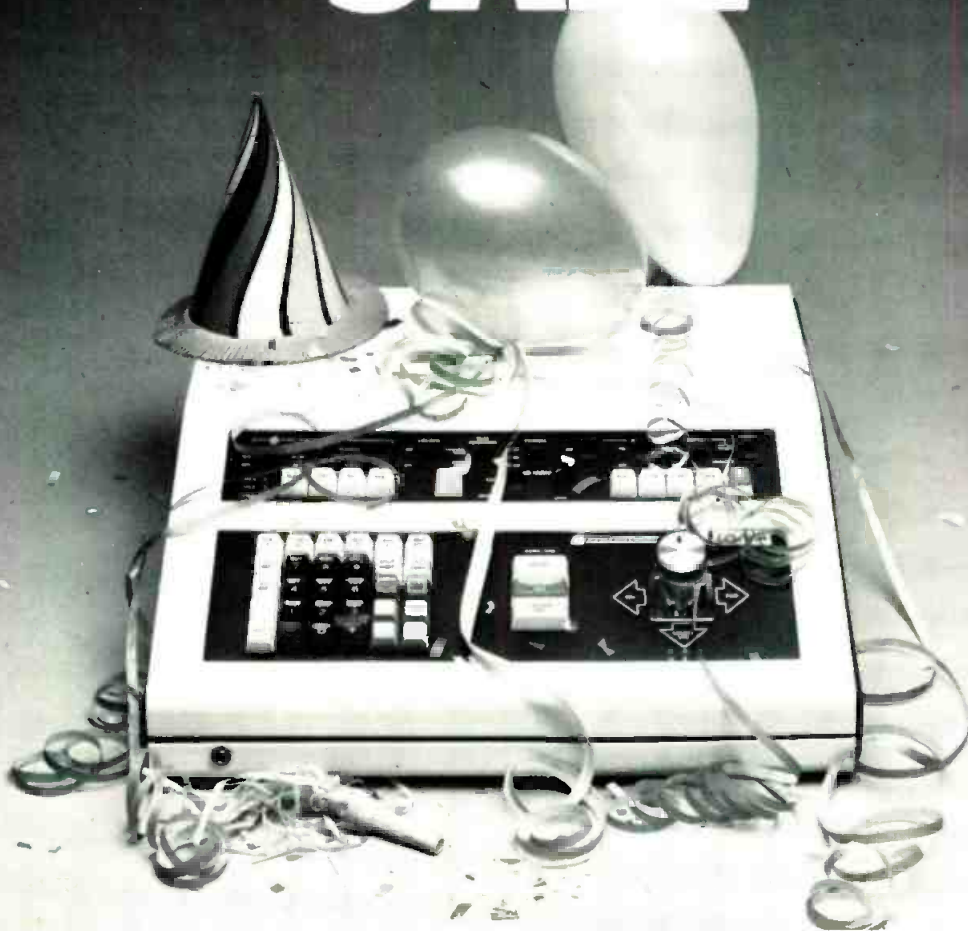

Twenty-five hundred Convergence ECS-100 Series video editing systems have now been delivered and we're celebrating!

The celebration means you can save money. New pricing is available on ECS-103B A/B roll editing systems, ECS-104 list management editing systems, and all of the ECS-103/104 upgrade kits.

ECS-100 Series edit systems have been to the Olympics, political conventions and a Royal Wedding. They help edit drama, music and training; documentary, comedy and commercials. We're proud of their history and will support their future with options, new interfaces and upgrades. This is

equipment that can continue to grow with your needs.

Join the celebration. Join the 2500. Call your dealers or local sales office today.

**CONVERGENCE
CORPORATION**

1641 McGaw, Irvine, CA 92714. (714) 549-3146. Telex: 277717 CONVUR
250 W. 57th Street, Fisk Building, Suite 815, New York City, NY 10019
3575 Cahuenga Blvd., West, Los Angeles, CA 91403. (213) 506-POST

Circle 142 on Reader Service Card

www.americanradiohistory.com

Manufacturers

AMPEX CORP. MAGNETIC TAPE DIV. ✓

401 Broadway, Redwood City, CA 94063
415 367-3809

Open-reel audio tape & cassettes; one-inch, two-inch, half-inch & 3/4-inch videotape & cassettes; instrumentation tape; empty reels, cases, cassettes.

See ad on pg. 135

AMTEL SYSTEMS, INC. ✓

29-16 Connell Ct., Toronto, Ont. M8T 5T7, Canada
416 251-3355

SMPTTE time code generators, readers; safe title area & countdown generators; digital clocks, master & slave clocks, timers, time distribution.

AMTRON CORP. ✓

2260 Dela Cruz Blvd., Santa Clara, CA 95050
408 748-8500

Sync generators; mono, NTSC color & RGB video monitors; video test signal generators.

ANACOMP, INC., CMS DIV. ✓

6610 N. Shadeland Ave., Indianapolis, IN 46220

317 842-1830/800 428-9281

AM/FM radio, TV & radio network business computer system; radio music rotation system.

ANALOG DEVICES, INC. ✓

Box 280, Norwood, MA 02062
617 329-4700

Video A/D & D/A converters, NTSC encoders & decoders.

ANCHOR SYSTEMS, INC. ✓

4510 Federal Blvd., San Diego, CA 92102
714 262-9901

Audio monitors for TV.

ANDREW CORP. ✓

10500 W. 153 St., Orland Park, IL 60462
312 349-3300

Transmit/receive, receive only & transportable satellite earth stations; intercity & portable ENG microwave; microwave, satellite & waveguide STLs; HP & CP TV antennas; microwave, satellite dish & communications antennas; solid core, foam dielectric & fiberoptic transmission line.

ANGENIEUX, INC. ✓

12901 SW 74 St., Miami, FL 33183
305 386-1740

Camera lenses & lens extenders; equipment rental service.

ANIXTER-MARK ✓

2180 S. Wolf Rd., Des Plaines, IL 60018
312 298-9420

Transmit/receive, receive only & transportable satellite earth stations; intercity & portable ENG microwave; microwave, satellite dish & communications antennas; foam dielectric transmission line.

R.B. ANNIS CO. ✓

1101 N. Delaware St., Indianapolis, IN 46202
317 637-9282

Audio & video head degaussers & bulk erasers; calibrated magnetic field indicators.

ANRITSU ✓

128 Bauer Dr., Oakland, NJ 07436
201 337-1111

Spectrum analyzers; tracking generator network analyzer; logic analyzers; electronic counter; power meters; electronic voltmeters; level meters; frequency synthesizers; transmission measuring sets; resistance attenuators; field strength meters; microwave system analyzers; PCM multiplex test set; digital error analyzer; optical power meters, optical pulse echo tester; personal computer; waveform monitors; laser measuring system.

ANTENNAS FOR COMMUNICATIONS, INC. ✓

486 Cypress Rd., Ocala, FL 32672
904 687-4121

Microwave antennas.

ANTENNA TECHNOLOGY CORP. ✓

3488 S. Highland Dr., Las Vegas, NV 89109

702 733-9658

Transmit/receive, receive only & transportable satellite earth stations.

ANTON/BAUER, INC. ✓

1 Controls Dr., Shelton, CT 06484
203 929-1100

Nicad & silver-zinc batteries & chargers; ac power supplies. Camera remote control system. Portable lighting heads.

See ad on pg. 17

ANVIL CASES, INC. ✓

4128 Temple City Blvd., Rosemead, CA 91770

213 575-8614

Foam insert & rack configuration transportation cases.

APERT-HERZOG CORP. ✓

7007 Realm Dr. (B3), San Jose, CA 95117
408 225-1425

Digital still stores; frame synchronizers; logic analyzers.

APHEX SYSTEMS, LTD. ✓

13340 Saticoy St., N. Hollywood, CA 91605
213 765-2212

AM & FM compressor/limiters; parametric equalizers; aural exciters.

APPLELOG ✓

357 N. Main St., Butler, PA 16001
412 283-1500

Radio business automation hardware; automated traffic/billing.

APPLIED DIGITAL TECHNOLOGY ✓

17 E. 96 St., New York, NY 10028
212 289-8660

SMPTTE time code synchronizers.

ARBEN DESIGN ✓

9870 Derby Lane, Westchester, IL 60153

312 345-1545

Modular studio sets; scenery construction; props, studio set design; prefabricated hard cycloramas.

ARISTOCART, DIV. WESTERN INTL. COMMUNICATIONS LTD. ✓

1960-505 Burrard St., Vancouver, BC V7X 1M6 Canada

604 687-2844

Audio carts & test tapes, empty reels & carts; cart storage units.

See ad on pg. 92

Refer to Reps/Distributors section

TOBY ARNOLD & ASSOC. ✓

4255 LBJ, Suite 156, Dallas, TX 75234
214 661-8201

Syndicated radio programming; music library.

ARRAKIS SYSTEMS ✓

1713 Wilcox Ct., Fort Collins, CO 80524
303 221-2918

Mic mixers, portable audio consoles, stereo & mono studio consoles; preamps, line, monitor & power amps; audio DAs, amp power supplies; VU & LED audio level indicators.

ARRIFLEX CORP. ✓

500 Route 303, Blauvelt, NY 10913
914 353-1400

Cine cameras; tripods, heads & stabilizing systems; HMI lighting fixtures; lighting stands & rigging; nicad batteries, chargers.

ARTEL COMMUNICATIONS CORP. ✓

Box 100, Worcester, MA 01602
617 752-5690

Remote pickup equipment; fiberoptic STLs; fiberoptic transmission line.

ARVIN/DIAMOND ✓

4465 Coonpath Rd., Carroll, OH 43112
614 756-9222

Weather satellite receivers.

ASACA/SHIBASOKU CORP. ✓

12509 Beatrice St., Los Angeles, CA 90066
213 827-7144

Monochrome video cameras; videotape cleaners & evaluators; portable & compact studio/mobile production switchers; stand-alone video effects generators; downstream keyers; sync, black burst, color bar & multiburst generators; NTSC encoders; NTSC, RGB & dc portable monitors; monitor calibrators; audio test signal generators, harmonic distortion meters; video test signal generators, automatic VITS analyzers, video noise meters.

ASHLY AUDIO, INC. ✓

100 Fernwood Ave., Rochester, NY 14621
716 544-5191

FM compressor/limiters; parametric equalizers; noise reduction; electronic crossovers.

ASTATIC CORP. ✓

Box 120, Conneaut, OH 44030
216 593-1111

Phono cartridges & pickup arms; dynamic, electret/condenser & lavalier mics; mic stands, booms & dollies.



The most advanced editor now costs less than stripped-down units.

Mach One® Series II from Bosch-Fernseh. The fastest, easiest-to-use, and most powerful videotape editor on the market.

Now, we're making it the most affordable editor.

Less is more.

Series II is our second generation Mach One system—with a combination of advanced features no other computer-assisted editor can match. Regardless of cost.

Features like **dual-channel audio control** to give you independent control over two separate audio tracks plus the video channel.

Variable speed control to let you select any of 16 shuttle-jog speeds in either direction.

Programmable slow motion to let you program your selected speeds in the edit list—with the sequences completely repeatable.

Updated edit list formatting to give you 6-digit alphanumeric reel numbers and various other edit list features.

Cluster-event programming to let you program complicated multiple events in a "cluster" treated as a single event—and preview or record in one pass rather than event-at-a-time.

Screen highlighting to brighten the edit line you're working on while dimming the rest of the screen—so you'll never strain your eyes or your nerves, and never lose your place.

There's no comparison.

Despite all its power, all its speed, all its capability, Mach One Series II costs less than many stripped-down editors. And *far* less than any remotely comparable system.

Second best—or second generation?

Now you don't have to settle for less editing power than you need because your budget can't handle your first choice. We're making the choice easy. You can have the second generation instead of the second best.

Your local Bosch-Fernseh office has full details. Call them. Or get in touch with us directly: Fernseh Inc., P.O. Box 31816, Salt Lake City, UT 84131, (801) 972-8000.

BOSCH



Manufacturers

ASTIN/ZAPPIA ✓
3501 Cahuenga Blvd. W., Los Angeles, CA 90068
213 876-8008
Video post-production facility.

ASTRO VIDEO SERVICES
61 W. Erie St., Chicago, IL 60610
312 280-5520
Video post-production facility.

ATI-AUDIO TECHNOLOGIES, INC. ✓

328 W. Maple Ave., Horsham, PA 19044
215 443-0330
Phono preamps; ALC & AGC amps, AM & FM compressor/limiters; parametric equalizers; noise reduction; audio preamps, line, monitor & power amps; audio DAs; amp power supplies; VU meters; audio patch panels, jackfields.
[See ad on pg. 176](#)
Refer to Reps/Distributors section

ATLANTIC RESEARCH CORP. ✓
5390 Cherokee Ave., Alexandria, VA 22314
703 642-4000

Portable, mono & stereo studio, automated & audio-for-TV mixing consoles; AM & FM compressor/limiters, parametric & graphic equalizers; slide attenuators; audio patch panels.

ATLAS SOUND ✓
10 Pomeroy Rd., Parsippany, NJ 07054
201 887-7800

Monitor speakers; mic stands, booms & dolies; lighting stands & rigging.

ATLAS TOWER CORP. ✓
227 South Vann, Box 972, Vinita, OK 74301
918 256-7883

Towers, masts, tower hardware & construction equipment, tower lighting.

AUBURN INSTRUMENTS
34 Lodge Rd., Newton, MA 02165
617 332-7747

Parallel interface machine control system; digital blanking meter.

AUDICO, INC. ✓
219 Crossen Ave., Elk Grove, IL 60007
312 640-1030

Audio tape loaders, timers & rewinders; cassette labels; videotape loading systems; tape unloader; videotape cleaner.

AUDI-CORD CORP. ✓
1845 W. Hovey Ave., Normal, IL 61761
309 452-9461

Single, dual/triple & time delay audio cart player/recorders; replacement audio heads.

AUDIO ACCESSORIES, INC. ✓
Mill St., Marlow, NH 03456
603 446-3335

Audio patch panels, telephone jacks, patch cords, jackfields.

AUDIOARTS ENG., DIV. WHEATSTONE CORP. ✓
5 Collins Rd., Bethany, CT 06525
203 393-0887

Broadcast production & on-air audio con-

soles, FM compressor/limiters; parametric & graphic equalizers.

AUDIO + DESIGN ✓
Box 786, Bremerton, WA 98310
206 275-5009/5010

ALC & AGC amps, AM & FM compressor/limiters, parametric & graphic equalizers, analog special effects & reverb, audio noise reduction, de-esser; audio preamps, audio DAs; VU, PPM & LED meters.

AUDIO DEVELOPMENTS ✓
414 N. Sparks St., Burbank, CA 91506
Mic mixers; portable, mono & stereo studio, TV audio consoles.

AUDIO KINETICS, INC. ✓
4721 Laurel Canyon Blvd., Ste. 209, N. Hollywood, CA 91607
213 980-5717
SMPTE time code generators & readers; time code synchronizing systems.

AUDIO METRICS ✓
5131 W. Chester Pk., Edgemont, PA 19028
215 356-4700

Broadcast audio consoles; phono preamps; audio DAs; studio timers.

AUDIONICS OF OREGON ✓
934 NE 25, Portland, OR 97232
503 239-5343

ATR replacement electronics; phono preamps; multichannel audio synthesis; monitor & power amps.

AUDIO PLUS VIDEO INTL. ✓
240 Pegasus Ave., Northvale, NJ 07647
201 767-3800

Digital standards conversion service.

AUDIO PROCESSING SYSTEMS, INC. ✓

Box 8, 90 Oak St., Newton Upper Falls, MA 02164

617 965-1200
Portable audio consoles, mono & stereo studio consoles, automated consoles; parametric & graphic equalizers; VU & PPM meters.

AUDIO-TECHNICA U.S., INC. ✓
1221 Commerce Dr., Stow, OH 44224
216 686-2600

TV audio consoles; pickup arms, phono cartridges, record cleaning & care; headphones; dynamic, electret/condenser, shotgun & lavalier mics.

AUDIOTECHNIQUES, INC.
652 Glenbrook Rd., Stamford, CT 06906
203 359-2312

Audio equipment rentals, facility turnkey installations.

AUDIO TECHNOLOGY
1169 Tower Rd., Schaumburg, IL 60195
312 885-0066

Audio noise reduction; VU, PPM & LED meters; dB meters.

AUDIO/TEK, INC.
502-D Vandell Way, Campbell, CA 95008
408 378-5586

Audio tape duplicators; tape loaders.

AUDIOTRONICS CORP. ✓
7428 Bellaire Ave., N. Hollywood, CA 91605
213 765-2645

Audio cassette player/recorders. Monochrome video, and data display monitors.

AUDIO-VIDEO CORP. ✓
213 Broadway, Menands, NY 12204
518-449-7213

Equipment rental service; audio & video post-production facility; recording studio; mobile vehicle construction.

AUDISAR ✓
Box 1561, Bellevue, WA 98009
206 454-2040

Mic mixers, portable audio consoles; phono preamps; parametric & graphic equalizers; monitor speakers; telco interface equipment; audio preamps, line, monitor & power amps, audio DAs; audio patch panels; audio test signal generators; voltmeters, multimeters; transformers.

AUDITRONICS, INC. ✓
3750 Old Getwell Rd., Memphis, TN 38118
901 362-1350

Mono, stereo, automated & TV audio studio consoles; audio preamps, line amps, audio DAs; audio patch panels; programmable equalizers; digital audio adapters; PPMs.

[See ad on pgs. 48, 125](#)

Refer to Reps/Distributors section

AUERNHEIMER LABS & CO. ✓
4561 E. Florence Ave., Fresno, CA 93725
209 442-1048

Monitor speakers.

AURATONE CORP. ✓
Box 698, Coronado, CA 92118
714 297-2820

Monitor speakers.

AURORA SYSTEMS ✓
185 Berry St., San Francisco, CA 94107
415 777-2288

Digital art/paint systems with character generators, camera/VTR digitizers, weather symbol inserters; standalone video effects generators.

AUTOGRAM CORP. ✓
Box 456, 631 J Pl., Plano, TX 75074
214 424-8585

Mono, stereo, automated, TV audio studio consoles; audio test signal generators.

AUTOMATED BROADCAST CONTROLS, INC.
301 587-3505

Complete program automation systems, radio business automation hardware.

AUTOMATED BUSINESS CONCEPTS, DIV. CETEC
1110 Mark Ave., Carpinteria, CA 93013
805 684-7186

Radio business computer systems (MAPS).

AUTOMATED STUDIO TECHNOLOGIES ✓
25 W. 45 St., New York, NY 10036
212 398-0995

Complete editing system for audio or video post-production.



Boost transmitter efficiency with EIMAC TV tubes. VHF, UHF, MDS, ITFS.

EIMAC, a leader in communications tube design, introduces its new tubes for TV translators (transposers), low-power TV (LPTV), and TV transmitting service worldwide (VHF Bands I, II and III; UHF Bands IV and V).

In addition to concentrating on VHF and UHF applications, EIMAC has developed tubes specifically for Multipoint Distribution Systems (MDS) and Instructional TV Fixed Service (ITFS).

EIMAC tubes available cover power ranges from 100W to

1,000W peak sync/visual in the UHF range which can be used in combined aural and visual transmitting applications as well as separate duplexed transmitters. EIMAC tubes meet or exceed stringent IMD and gain requirements. Tubes used in MDS or ITFS service are capable of providing up to 50W peak sync/visual.

During the design phase, special attention was paid to efficient cooling and heater cathode operation for improved overall transmitter operation.

Varian EIMAC
1678 S. Pioneer Road
Salt Lake City, Utah 84104
Telephone: 801 • 972-5000, ext. 334

Varian AG
Steinhauserstrasse
CH-6300 Zug, Switzerland
Telephone: (042) 23 25 75
Telex: 78-841



Manufacturers

AUTOMATION TECHNIQUES, INC. ✓

1550 N. 105 E. Ave., Tulsa, OK 74116
918 836-2584

Black burst, color bar generators; video proc amps. Receive only satellite earth stations.

AVA ELECTRONICS ✓

4000 Bridge St., Drexel Hill, PA 19026
215 284-2500

DAs, line extenders; coax connectors; camera & lens accessories; RF amps, attenuators & filters; RF cable & connectors; TV combiners.

AVAB AMERICA, INC. ✓

967 Howard St., San Francisco, CA 94103
415 421-3562

Lighting control boards, dimmer packs.

AVANTEK, INC. ✓

3175 Bowers Ave., Santa Clara, CA 95051
408 727-0700

Microwave STLs; earth station LNAs, earth station receiver.

AVCOM ✓

500 Research Rd., Richmond, VA 23236

804 794-2500 ✓

Satellite receivers for home & commercial use.

AVL DIGITAL, LTD. ✓

70 Milner Ave. Unit 5, Scarborough, Ont. M1S 3P8, Canada
416 298-6220

Monitor & power amps, audio DAs. Parallel & serial interface routing switchers; sync, black burst, multiburst, countdown generators; video pulse amps & DAs. Video test signal generators.

AVONIX VIDEO SYSTEMS, INC. ✓

Box 505, Brookfield, WI 53005
414 784-1800

Video systems for production, post-production, ENG/EFP; automated video programming systems; video projection systems.

AVT TELEVISION PRODUCTIONS ✓

1466 Amherst Rd., Knoxville, TN 37919
615 584-2166

Mobile teleproduction facility.

WILLIAM BAL CORP. ✓

947 Newark Ave., Box 875, Elizabeth, NJ 07207

201 354-9625

Carrying & shipping cases for video equipment & accessories.

BALD MOUNTAIN LAB ✓

230 Bellevue Rd., Troy, NY 12180
518 279-9753

Audio test signal generators; dB meters; frequency measurement services.

BALLY CASE & COOLER, INC. ✓

P.O. Box 98, Bally, PA 19503
215 845-2311

Prefabricated, sectional insulated shelters.

BARBIZON ✓

426 W. 55 St., New York, NY 10019
212 586-1620

Lighting equipment rentals including lamps, HMI & quartz fixtures, lighting stands, connectors, dimmers.

BARCO ✓

See Elector

BARDA ELECTRONIC, INC. ✓

5180 Queen Mary Rd. #410, Montreal, Que. H3W 3E7 Canada

514 486-1186

Character generators, titlers.

BARDWELL & McALISTER, INC. ✓

7051 Santa Monica Blvd., Hollywood, CA 90038

213 466-9361

Lighting equipment including lamps, quartz fixtures, stands & rigging, cyc lighting; grip equipment.

BARKER & WILLIAMSON ✓

10 Canal St., Bristol, PA 19007
215 788-5581

Communications antennas; RF power meters.

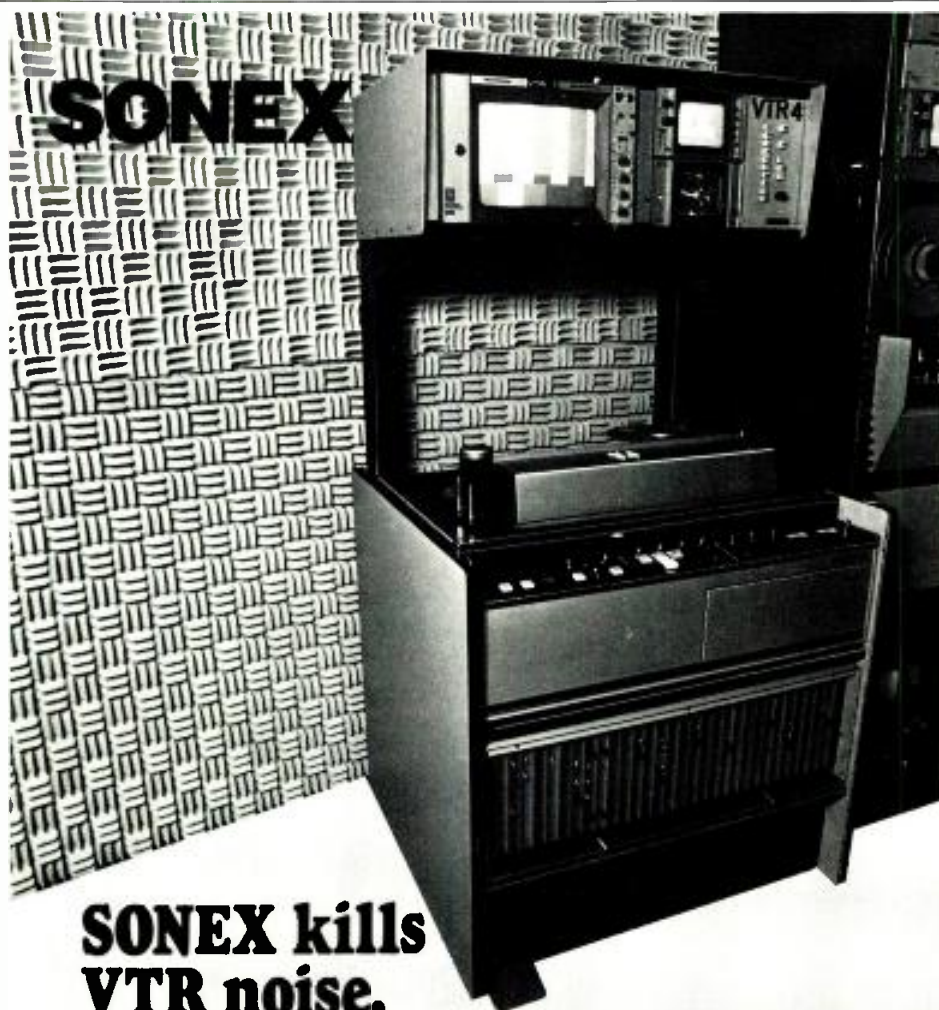

SONEX kills VTR noise.

SONEX not only improves audio quality, inexpensively, but also quiets annoying background noise when you need to concentrate: noise from Quad VTR head blowers and head wheels; from mechanical tape transports; even from computer disk drives and fans. SONEX is the art of shaping sound...and the workhorse of killing noise.

Get the facts today. SONEX is manufactured by Illbruck/usa and distributed exclusively to the pro sound and A/V industries by Alpha Audio, 2049 W. Broad Street, Richmond, VA 23220.



Alpha Audio

804/358-3852

Acoustic Products
for the Audio Industry

Circle 145 on Reader Service Card

BASF SYSTEMS CORP. ✓
Crosby Dr., Bedford, MA 01730
617 271-4000
Open-reel & cassette audio tape; test tapes; videocassettes.

BASYS, INC. ✓
2685 Marine Way, Mountain View, CA 94043
415 969-9810
Radio & TV newsroom computer systems.

BAY AREA MOBILETAPE
1031 E. San Carlos Ave., San Carlos, CA 94070
415 593-7124
Mobile teleproduction facility; video post-production facility.

BAYLY ENGINEERING, LTD. ✓
(AEG-TELEFUNKEN)
167 Hunt St., Ajax, Ont. L1S 1P6 Canada
416 683-8200
Portable audio consoles; audio preamps, line, monitor & power amps, DAs; RF amps; surge protectors; FM exciters; FM, VHF, UHF transmitters; telco STLs; 2-way communications systems; equipment racks.

BEAVERONICS, INC. ✓
8 Haven Ave., Port Washington, NY 11050
516 883-4414
Large, compact & small production switchers; post-production switchers; SEGs; RGB chromakeyers; title & downstream keyers. Master/slave clocks.

BELAR ELECTRONICS LABORATORY, INC. ✓
Box 826, Devon, PA 19333
215 687-5550
AM stereo exciters; RF amps; demodulators; FM, TV SCA equipment; frequency monitors.
[See ad on pg. 146](#)

BELDEN COMMUNICATIONS, INC. ✓
534 W. 25 St., New York, NY 10001
212 691-1910
Lee filters, gels, resin camera filters.

BELL AUDIO SYSTEMS, INC.
994 Freeway Dr. N., Columbus, OH 43229
614 846-2766
Audio DAs, preamps, power, PA amps; audio cart player/recorders.

BELL HELICOPTER/TEXTRON, INC. ✓
Box 482, Ft. Worth, TX 76101
817 280-8200
Helicopters.

BEST AUDIO ✓
5422 Farr Ave., N. Hollywood, CA 91601
213 763-2378
Production & post-production equipment rentals; audio post-production services; TV audio remote units.

BESTON ELECTRONICS INC. (BEI) ✓
15315 S. 169 Highway, Box 937, Olathe, KS 66061
913 764-1900
Character generators; video countdown

generators; automatic weather/time displays; teleprompters; automatic telecine light controls, projectors.

BEYER DYNAMIC, INC. ✓
5-05 Burns Ave., Hicksville, NY 11801
516 935-8000
Headphones; full line of mics including RF models; mic stands, booms, fixtures.

[See ad on pg. 115](#)
Refer to Reps/Distributors section

BG ENGINEERING
632 Commercial St., San Francisco, CA 94111
415 444-5986
Digital tape timers.

BGW SYSTEMS, INC. ✓
13130 S. Yukon, Hawthorne, CA 90250
213 973-8090
Audio monitors, power amps; crossovers.



THE ONLY FULL CAPABILITY VIDEO NOISE METER

Model UPSF2



- **DUAL-STANDARD:** μ P automatically determines standard (525/625 lines), identifies it on the display, and performs the appropriate measurement.

- **Measurement Domain:** Full-field, any individually selected line, any individual "spot" (4 μ s x 10 lines)

- IEEE-488 (GPIB) Bus Compatible

- **Video Level Measurement:** Luminance-bar amplitude, or individual test-points selectable in steps of 1 μ s (range: -500 to +1500 mV)

- **Noise Measurement:** Luminance (peak or rms) or Chrominance (AM or ϕ M). Range: 0-80 dB, referenced to 714 mV (525 lines), 700 mV (625 lines), or actual luminance-bar amplitude.

Send for our new catalog



ROHDE & SCHWARZ

13 Nevada Drive, Lake Success, N.Y. 11042 • (516)488-7300 • Telex 96-0072

Manufacturers

BIRD ELECTRONIC CORP. ✓
30303 Aurora Rd., Solon, OH 44139
216 248-1200
RF attenuators, filters, loads, switches. RF wattmeters, calorimeters, RF power monitors/alarms; radio test sets.

BIRNS & SAWYER, INC. ✓
1026 N. Highland Ave., Hollywood, CA 90038
213 466-8211
Cine cameras, lenses, filters, accessories; film editing equipment. Tripods, heads, dollies. Lighting equipment including quartz fixtures, gels, filters. Portable teleprompters. Equipment rental services.

BIW CABLE SYSTEMS, INC. ✓
65 Bay Street, Boston, MA 02125
617 265-2102
Video, audio, lighting/ac, RF cable & connectors.

BLONDER-TONGUE LABS, INC. ✓
One Jake Brown Rd., Old Bridge, NJ 08857
201 679-4000
RF amps, loads, filters; FM, TV antennas; PTV, CATV, MATV systems, demodulators, receiving modulators, DAs.

BOGEN PHOTO, INC. ✓
100 S. Van Brunt St., Englewood, NJ 07631
201 568-7771
Tripods, heads & dollies; quartz lighting fixtures; still photographic equipment.

BOGNER BROADCAST EQUIPMENT CORP. ✓
401 Railroad Ave., Westbury, NY 11590
516 997-7800
FM, TV (HP and CP), microwave antennas; MDS down convertors.

BONNEVILLE BDCST. CONSULTANTS ✓
274 County Rd., Tenafly, NJ 07670
201 567-8800
Syndicated radio programming service.

BONNEVILLE PRODUCTIONS ✓
130 Social Hall Ave., Salt Lake City, UT 84111
801 237-2400
Audio line amps, DAs.

BOONTON ELECTRONICS CORP.
499 Pomeroy Rd., Box 122, Parsippany, NJ 07054
201 887-5110
Modulation monitors; RF power meters, wattmeters, voltmeters; RF signal generators; impedance bridges.

BOSCH ✓
2300 S. 2300 West, Salt Lake City, UT 84119
801 972-8000
Studio, field, ENG, single-piece cameras; recorder/cameras; one-inch B VTRs; video cart automation systems. Solid state telecines, optical multiplexers, color correctors. Character generators, graphics systems, digital art/paint systems. Real time animation. Serial interface routing switchers. Multisource editing systems. Color bar, SID generators. NTSC encoders. Audio editing systems, preamps, monitor amps, DAs.
[See ad on pg. 63](#)

BPI (BROADCAST PROGRAMMING INTL.)
Box 547, Bellingham, WA 98227
800 426-9082
Syndicated radio programming.

BRAND-REX CO. ✓
Box 498, Willimantic, CT 06226
203 423-7771
Solid core, foam dielectric & fiberoptic transmission cable; video, audio, lighting/ac cable & connectors.

BRINER-CHASE GROUP ✓
4685 Highland Dr., Ste. 208, Salt Lake City, UT 84117
801 272-8601
Broadcast automation, traffic, & billing systems.

BRITISH AEROSPACE ✓
Box 1714, Dulles Intl. Airport, Washington, DC 20041
703 435-9100
Communications satellite for DBS & TV distribution.

BRITISH VIDEOTEX AND TELETEXT/LOGICA
666 Third Ave., New York, NY 10017
212 599-0828
Teletext hardware & software.

BROADCAST AIDS, INC. ✓
20 Red Rose Drive, Levittown, PA 19056
215 547-7133
Digital clocks, timers.

BROADCAST AUDIO CORP. ✓
11306 Sunco Drive, Rancho Cordova, CA 95670
916 635-1048
Mono & stereo audio studio consoles; TV audio consoles; monitor/power amps, audio DAs.
[See ad on pg. 184](#)

BROADCAST CARTRIDGE SERVICE, INC. ✓
15131 Triton Lane, Ste. 108, Huntington Beach, CA 92649
714 898-7224
Loaded audio carts, empty carts, cart reconditioning service; phase meters.

BROADCAST ELECTRONICS, INC. ✓
4100 N. 24 St., Quincy, IL 62305
217 224-9600
Mono and stereo audio studio consoles; single, dual, multi, time delay cart player/recorders; tape loaders, rewinders, turntables, pickup arms, phono preamps; complete program automation systems; AM & FM compressor/limiters; telco interface equipment; preamps, line & monitor amps, audio DAs. FM transmitters, exciters, RF amps; FM SCA equipment.

BROADCAST MICROWAVE SERVICES, INC. ✓
7322 Convoy Ct., San Diego, CA 92111
619 560-8601
Intercity, ENG & airborne microwave & central receivers; STLs, microwave antennas; RF amps, filters, & diplexers; towers & masts.

BROADCAST MUSIC, INC. (BMI) ✓
320 W. 57 St., New York NY 10019
212 586-2000
Syndicated radio programming service.

BROADCAST SYSTEMS, INC. ✓
8222 Jamestown Dr., Austin, TX 78758
512 836-6011
Equipment rental service.

BROADCAST TECHNOLOGY CONSULTANTS ✓
6700 Squibb Rd., Ste. 104, Mission, KS 66202
913 677-1483
Engineering, facilities design consultant.

BROADCAST TECHNOLOGY, INC. ✓
33 Comac Loop, Ronkonkoma, NY 11779
516 588-6565
Mono, stereo, audio for TV studio consoles; mixers, portable mixers; graphic equalizers. Headphone amps; audio preamps, monitor & line amps, DAs, power amps; VU, PPM, LED level indicators. Serial & parallel interface routing switchers; audio processors; ENG & sports coverage production & communications equipment.

BROADCAST VIDEO SYSTEMS, LTD. ✓
1050 McNicoll Ave., Unit 15, Agincourt, Ont. M1W 2L8 Canada
416 497-1020
Distributors of Cox SEGs; RGB & encoded chromakeyers; title & downstream keyers; safe title area generator: NTSC encoders, decoders; comb filter decoders; delay lines & filters; color correctors; proc amps; passive video switchers. Manufacturers of automatic VITS analyzer, blanking width meter. Distributors of Electronic Visuals waveform monitors, vectorscopes, combination scopes. Hum bucking coils.

BRUEL & KJAER INSTRUMENTS, INC. ✓
185 Forest St., Marlborough, MA 01752
617 481-7000
Electret/condenser microphones. Audio signal generators, harmonic distortion meters, IM meters, spectrum analyzers, wow & flutter meters, time delay spectrometry.

BRYSTON MFG., LTD.
57 Westmore Dr., Rexdale, Ont. M90 3Y6 Canada
416 746-1800
Audio preamps, monitor/line amps.

BSM BROADCAST SYSTEMS, INC. ✓
Box 8081, Spokane, WA 99203
509 448-0697
Portable & studio audio consoles; audio DAs; audio routing switchers; remote controls.
[See ad on pg. 139](#)
Refer to Reps/Distributors section

THE BTX CORP. ✓
75 Wiggins Ave., Bedford, MA 01730
617 275-1420
SMPTE time code generator/readers, time code synchronizers, audio/video interfaces;



Ikegami ITC-730 expands your ENG coverage, tightens your budget.

When Ikegami designed the ITC-730 ENG camera, we set out to create the world's finest modestly-priced, hand-held TV camera. And we succeeded.

Look at what the ITC-730 ENG gives you for under \$10,000* (less lens). A lightweight, 3-tube prism optics camera featuring advanced Saticon II** tubes, a 2H detail corrector, noise-free contrast compression circuitry, and a character generator in the viewfinder that indicates filter selection, gain selection, auto-white balance, VTR start/stop, gen-lock, and battery test.

The f/1.4 RGB prism beam-splitter delivers low-light performance (a standard sensitivity of 2000 lux at f/4), and a consistent 54 dB S/N ratio from the preamp.

And when you're out there shoot-

ing, you get even more. You can go farther and last longer because the ITC-730's unique circuitry makes it a miser on power consumption. Shoot up to three hours on one fully charged Nicad battery.

The ITC-730 is easy to handle. It has an excellent weight/balance ratio for smooth shooting from the shoulder. And its low profile makes it as easy to see over as it is to handle. A rugged magnesium alloy, die-cast housing takes the inevitable bumps in stride.

Equipped for EFP, the ITC-730 expands the limits of field production. It can be remotely operated up to 1000 feet from the CCU on AC; up to 300 feet on battery power from the camera.

ENG or EFP, you'll never have to accept anything less than an Ikegami again. Contact us for details.



Ikegami ITC-730

Ikegami Electronics (USA) Inc., 37 Brook Avenue, Maywood, NJ 07607.

Northeast: (201) 368-9171 Midwest: (219) 277-8240 West Coast: (213) 534-0050 Southwest: (713) 445-0100 Southeast: (813) 884-2046

*Manufacturer's suggested list price **TM of Hitachi Ltd.

Circle 147 on Reader Service Card

www.americanradiohistory.com

Manufacturers

electronic editors/controllers.

BUHL OPTICAL ✓
1009 Beech Ave., Pittsburgh, PA 15233
412 321-0076
35 mm telecine slide projectors, optical multiplexers.

BULLET RECORDING
49 Music Square W., Nashville, TN 37203
615 327-4621
Teleproduction & post-production facilities.

THE BURBANK STUDIOS ✓
4000 Warner Blvd., Burbank, CA 91522
213 954-6000
Teleproduction facility.

RICHARD W. BURDEN ASSOC. ✓
20944 Sherman Way, Canoga Park, CA 91303
213 340-4590
Manufacturer of audio test signal generators. Distributor of full line of audio equipment. Engineering, facility design consulting.

BUSH & MILLIMAKI SERVICES, INC. ✓
902 Bob Wallace Ave., Huntsville, AL 35801
205 533-9274
Tri-color video collimator. Universal tripods & heads. Lens repair service.

B-W LIGHTING SYSTEMS ✓
Box 470162, Tulsa, OK 74147
918 664-1111
Full line of lighting equipment including lamps, HMI, CSI & quartz fixtures, stands & rigging, lighting control boards & dimmer packs, cyc lighting; cyc track & curtains. Transportation cases. Studio furniture, equipment racks. Lighting cable, connectors, jackfields. Engineering consulting, set design services.

CABLEWAVE SYSTEMS, INC. ✓
60 Dodge Ave., North Haven, CT 06473
203 239-3311
Intercity microwave links, microwave & waveguide STLs; microwave antennas; foam dielectric transmission line, connectors; carrier current systems.

CADO SYSTEMS CORP.
2771 Toledo St., Torrance, CA 90503
213 320-9660
Radio business automation hardware & software; music format control.

CALICO VIDEO CO., INC.
8955 Thornton Rd., Stockton, CA 95209
209 952-3333
Video carts for TCR-100, cart rebuilding.

CALIFORNIA INSTRUMENTS ✓
5150 Convoy St., San Diego, CA 92111
714 279-8620
Ac power inverters, converters, inverters.

CALIFORNIA MICROWAVE, INC. ✓
990 Almanor Ave., Sunnyvale, CA 94086
408 732-4000
Transmit/receive, receive only, transportable satellite earth stations; PTV scramblers; facility turnkey installation, engineering consult-

ing, satellite earth station site selection services.

CALREC AUDIO, LTD. ✓
Audio & Design, Box 786, Bremerton, WA 98310
206 275-5009/5010
Capsular, electret/condenser, sound field mics; audio preamps.

CALVERT ELECTRONICS, INC. ✓
1 Branca Rd., E. Rutherford, NJ 07073
800 526-6362
Camera pickup tubes. Lamps. RF amplifiers; RF power tubes. Video & audio cable, RF cable.

CALZONE CASE CO. ✓
Box 862, S. Norwalk, CT 06856
203 853-7907
Foam insert & rack configuration transportation cases. Studio furniture, tape storage units, equipment racks.

CAMBRIDGE PRODUCTS CORP.
244 Woodland Ave., Bloomfield, CT 06002
203 243-1761
Cable connectors.

THE CAMERA MART, INC. ✓
456 W. 55 St., New York, NY 10019
212 757-6977
Equipment rental service. East coast distributor of Ikegami EC-35; U.S. distributor Multidyne products & Milab audio products. Distributor of Ronford tripods, heads, legs.
[See ad on pgs. 4, 111](#)

CANDEX PACIFIC, INC.
693 Veterans Blvd., Redwood City, CA 94404
415 364-8427
Engineering consultant.

CANON USA, INC. ✓
1 Canon Plaza, Lake Success, NY 11042
516 488-6700
TV & cine camera lenses, lens accessories.
[See ad on pg. 71](#)
Field Offices:
CA 123 Paularino Ave. East,
Costa Mesa 92626. 714 979-6000
GA 6380 Peachtree Industrial Blvd.,
Norcross 30071 404 448-1430
IL 140 Industrial Dr.,
Elmhurst 60126. 312 833-3070

CAPITOL MAGNETIC PRODUCTS ✓
6902 Sunset Blvd., Hollywood, CA 90028
213 461-2701
Audio carts, bulk tape; master disk recording blanks.
[See ad on pg. 34](#)

CARLETON PRODUCTIONS ✓
1500 Merivale Rd., Ottawa, Ont. K2C 3G6
Canada
613 224-1313
Studio & mobile teleproduction facility; video post-production facility.

CAROB VIDEO ✓
250 W. 57 St., New York, NY 10019
212 957-9525
Video post-production facility.



CASES, INC. ✓
1745 W. 134 St., Gardena, CA 90249
213 770-4444
Foam insert & rack configuration transportation cases, equipment racks.

CAT SYSTEMS, INC. ✓
401 E. 74 St., New York, NY 10021
212 988-0290
Computerized automation for telesystems, remote control systems. Facility turnkey installations, engineering & computer consultants.

CATEL, DIV. UNITED SCIENTIFIC CORP. ✓
4800 Patrick Henry, Santa Clara, CA 95054
408 988-7722
RF amplifiers, converters, stereo generators, modulators.

CAVOX-TAPEATHON CORP. ✓
502 S. Isis Ave., Inglewood, CA 90301
800 421-1029
Relay & time insertion automation sequencers; complete automation systems; auto time/weather announcers; tape duplicating services; portable & studio open-reel tape player/recorders; syndicated radio programming services.

CCR POST, INC. ✓
135 E. 55 St., New York, NY 10022
212 753-9230
Video post-production facility.

CCR VIDEO CORP. ✓
135 E. 55 St., New York, NY 10022
212 753-7341
Mobile teleproduction facility.

CECO COMMUNICATIONS, INC. ✓
2115 Ave. X, Brooklyn, NY 11235
800 221-0860
Industrial tubes; high power transmitting tubes; receiving tubes. Single-tube & b&w video cameras; solid state cameras; lenses & pickup tubes; videotape, empty reels; mono, NTSC, RGB & dc portable video monitors; video projectors; video DAs. RF power tubes. Vacuum tubes, solid state components, rectifiers, connectors.
[See ad on pg. 154](#)

CELESTIAL MECHANIX
612 Hampton Dr., Venice, CA 90291
213 392-8771
Video production & special effects.

CENTER CITY VIDEO, INC.
1503 Walnut St., Philadelphia, PA 19102
215 568-4134
Studio & mobile teleproduction facilities; video post-production facility.

CENTER VIDEO CENTER, INC.
5565 N. Elston Ave., Chicago, IL 60630
800 621-4354
Editing, production consoles. Equipment rental services; video post-production facility; studio, set design.

40 to 1

Canon PV40 x 13.5B IE: THE OLYMPIAN

Canon moves you a giant step forward with a 40X broadcast quality zoom lens. An incredible new lens that allows you to cover a stadium at wide angle or fill the frame with the quarterback's eyes.

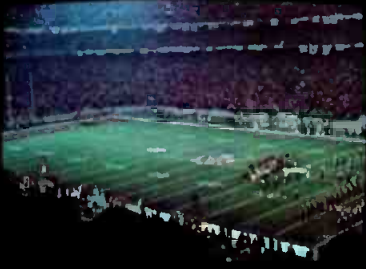

controlled cameras.

We call it The Olympian. Not only because it is ideally suited for sports coverage but also because of the dedication and team effort required of our optical and electronic engineers in making this lens a reality.

Never before has a single lens provided this much flexibility and sensitivity, with remarkably little change in effective aperture throughout its entire 13.5mm-540mm* range. Built-in extenders let you go all the way to 1080mm and each lens is diascopy-equipped for modern microprocessor-

Enlarge a dollar bill forty times and it covers an area twenty feet long and eight feet wide. Now think about what you could do with the Canon PV 40 x 13.5B IE!

*1" cameras. Also available in 30mm plumbicon.



Canon[®]

Optics Division

Canon USA, Inc., Head Office: One Canon Plaza, Lake Success, N.Y. 11042 (516) 488-6700

Dallas Office: 11311 Stemmens Freeway, Suite 1, Dallas, Texas 75229 (214) 620-2641 Chicago Office: 140 Industrial Drive, Elmhurst, Ill. 60126 (312) 833-3070

West Coast Office: 123 Paularino Avenue East, Costa Mesa, Ca. 92626 (714) 979-6000

Canon Canada, Inc., 3245 American Drive, Mississauga, Ontario L4V1B8, Canada (416) 678-2730

© 1982 Canon U.S.A., Inc.

Circle 148 on Reader Service Card

www.americanradiohistory.com

**In the past ten years,
computers have gotten smarter,
cameras have gotten simpler,
ovens have gotten quicker,
beer has gotten lighter,
bodies have gotten leaner,
athletes have gotten richer,
hi-fi has gotten higher,
radio has gotten stronger,
studios have gotten smaller,
towers have gotten taller,
movies have gotten longer,
cars have gotten shorter,
film has gotten faster,
outerspace has gotten closer
and blue jeans have gotten classier.**

Now it's our turn.

In the past 10 years, the Premium Line from ITC has seen refinements, but no major changes. Frankly, it hasn't needed any. The Premium Line has been a dependable workhorse that's found its way into more studios than its next two competitors combined.

But we couldn't leave well enough alone. So this year, the Premium Line gives way to the Delta Series, a new generation of cartridge machines that offers you more than ten years worth of improvements.

It's mechanically better. The cart guides are improved. There's a crystal-referenced servo capstan motor with a vapor-honed non-magnetic shaft. Modular construction makes alignment and service convenient. High-speed recue is standard. And the Delta III gives you three

independently removable decks.

It's electronically better. There are new, high performance components, including NE5500 Series amplifiers. There's an exclusive ITC/3M playback head for smooth frequency response and improved signal-to-noise. We've added a toroidal power transformer with fully regulated and protected power supplies. And a digital cue tone detector controlled by a powerful microprocessor.

And it's physically better because it's smaller. The whole unit is only one-third rack width (5 $\frac{5}{8}$ "'). The enclosure is made of $\frac{1}{4}$ -inch milled or cast aluminum, for stability. And the panel inserts are made of Lexan®.

Of course, we left in all the good things that made the

Premium Line so popular. The $\frac{1}{2}$ -inch tool plate aluminum deck. Durable, high quality switches. And a solenoid-actuated, chain-and-sprocket pressure roller assembly. All backed by our famous two-year warranty on parts and factory labor, plus a 30-day guarantee of satisfaction. If, for any reason, you're not completely satisfied, you can return the unit within 30 days of purchase and we'll refund your money in full.

The good things are still there. But what you'll notice are the improvements. We think they were worth the wait.

For more information, or to place an order, call us collect from Alaska, Hawaii or Illinois, at 1-309-828-1381. From the rest of the U.S., call the following. Toll-free number:

1-800-447-0414.

1983

1973



INTERNATIONAL TAPETRONICS CORPORATION

3M hears you...

3M

Manufacturers

CENTRAL DYNAMICS CORP. ✓

401 Wynn Dr. NW, Huntsville, AL 35805
205 837-5180

AMERICAN DATA: Portable, large & compact production switchers; post-production switchers; colorizers, RGB chromakeyers, title & downstream keyers; manual master control switchers; parallel & serial interface routing switchers; black burst generators; pulse amps, video DAs.

CENTRAL DYNAMICS: Large, compact/mobile & automated video production switchers, post-production switchers; standalone effects generators, RGB & encoded chromakeyers, title & downstream keyers; manual, automated & business automation interfaced master control switchers; video signal & cable equalizers; video pulse amps, DAs & sc amps. Audio preamps, line, monitor & power amps, audio DAs, amp power supplies.

See ad on pgs. 5, 167

Field Offices:

CA 3760 Cahuenga Blvd. West,
N. Hollywood 91604 . . . 213 766-8185
IL 331 W. Northwest Hwy.,
Palantine 60067 312 991-4720
NY Honeywell Bldg., Ste. 570,
570 Taxter Rd.,
Elmsford 10523 914 592-5440
CN Central Dynamics Ltd.,
147 Hymus Blvd., Pointe Claire,
Montreal,
Que. H9R 1G1 514 697-0811
CN Central Dynamics Ltd.,
Ste. 201,
801 York Mills Rd.,
Don Mills, Ont.
M3B 1X7 416 446-1543

CENTRO CORP. ✓

9516 Chesapeake Dr., San Diego, CA 92123
619 560-1578

Mobile van construction; facility turnkey installation; TV studio design.

See ad on pg. 147

Field Offices:

CA 2029 Century Pk E., Ste. 4220,
Los Angeles 90067 . . . 213 203-8033
VA 8260 Greenboro Dr., Ste. 600-A,
McLean 22101 703 821-8111

CENTURY PRECISION CINE/ OPTICS ✓

10713 Burbank Blvd., N. Hollywood, CA 91601

213 766-3715

Cine & video camera lenses; periscope, wide angle adapter; lighting; filters; motion picture accessories; cine & video adapters & special modifications.

CENTURY III TELEPRODUCTIONS, INC. ✓

651 Beacon St., Boston, MA 02115
617 267-6400

Teleproduction & video post-production facilities.

CENTURY 21 PROGRAMMING, INC. ✓

4340 Beltwood Pky., Dallas, TX 75234
800 527-5959

Syndicated radio programming services.

CETEC ANTENNAS ✓

Box 28425, 6939 Power Inn Rd., Sacramento, CA 95828

916 383-1177

FM, TV (HP & CP) antennas. RF filters, power dividers, duplexers.

CETEC BROADCAST GROUP ✓

1110 Mark Ave., Carpinteria, CA 93013
805 684-7686

Portable, mono & stereo studio & audio for TV mixing consoles; turntables & pickup arms; complete program automation systems; time insertion sequencers, computer controllers, auto time/weather announcers, business automation computer systems.

CETEC GAUSS ✓

9130 Glenoaks Blvd., Sun Valley, CA 91352
213 875-1900

High-speed audio tape duplicators, audio monitors.

CETEC VEGA ✓

9900 Baldwin Pl., El Monte, CA 91731
213 442-0782

RF intercoms; RF mics; tone encoders & decoders.

CEZAR INTERNATIONAL, LTD.

See International Video Corp.

CFI VIDEO

959 Seward St., Hollywood, CA 90038
213 462-3161

Video post-production facility.

CHANNELMATIC, INC.

821 Tavern Rd., Alpine, CA 92001
619 445-2691

Relay & time insertion automation sequencers, computer controllers; audio DAs. Video cart, cassette automation systems; video DAs. Remote control systems. Digital clocks, clock-controllers.

CHANNEL ONE VIDEO TAPE, INC. ✓

3341 NW 82 Ave., Miami, FL 33122
305 592-1764/212 926-6391

Studio & mobile teleproduction facilities; video post-production facility.

CHICAGO VIDEO, INC. ✓

48 E. University Dr., Arlington Hts., IL 60004
312 577-2430

Studio & mobile teleproduction facilities; video post-production facility.

JOHN CHILES, INC.

7622 Main St., Jacksonville, FL 32208
904 764-5281

Nicad batteries, chargers.

CHRIS CRAFT VIDEO TAPE CENTER

915 N. La Brea, Hollywood, CA 90038
213 851-1000 ext. 247

Video production & post-production facility.

CHRISTIE ELECTRIC CORP. ✓

20665 Manhattan Pl., Torrance, CA 90501
213 320-0808

Nicad batteries, chargers.

See ad on pg. 95

CHRONICLE PRODUCTIONS ✓

1001 Van Ness Ave., San Francisco, CA 94109

415 561-8663

Studio & mobile teleproduction facilities; video post-production facility.

CHRONO-LOG CORP. ✓

2 W. Park Rd., Havertown, PA 19083
215 853-1130

Digital clocks, master & slave clocks, timers, time distribution.

CHYRON CORP. ✓

265 Spagnoli Rd., Melville, NY 11747
516 249-3296

Character generators, character generator/framestores, digital art/paint systems, bit pad digitizers, weather symbol inserters, "draw-on-screen" systems.

CINEMA PRODUCTS CORP. ✓

2037 Granville Ave., Los Angeles, CA 90025
213 478-0711

ENG/EFP cameras, cine cameras, lenses; digital camera control unit. Tripods, heads, camera stabilizing system; lamps. HMI & quartz fixtures; nicad batteries, chargers; ENG/EFP portable teleprompters. Video camera service.

CINEMA VIDEO CENTER

211 E. Grand, Chicago, IL 60611
312 527-4050

Teleproduction facility.

CINEMILLS CORP. ✓

3500 W. Magnolia Blvd., Burbank, CA 91525
213 843-4560

Daymax high-intensity bulbs for Strand Century & Arriflex HMIs; equipment distributor.

CINE 60, INC. ✓

630 Ninth Ave., New York, NY 10036
212 586-8782

Nicad power supplies, chargers; portable lighting units; ENG braces.

CINETAPE ✓

801 N. La Brea, Hollywood, CA 90038
213 934-8836

Teleproduction & post-production facilities.

CINETRONICS, INC. ✓

304 S. Broadway, Ste. 510, Los Angeles, CA 90013

213 617-0976

Film production, teleproduction & video post-production facilities.

CIPHER DIGITAL ✓

150 Huntington Ave., Boston, MA 02115
617 267-1148

SMPTE/VITC time code readers, generator/translators; time code coincidence detector.

CIRCUIT DEVELOPMENT CO., INC.

1029 Utica Ave., Brooklyn, NY 11203
212 346-1212

Three-channel RF monitors; 2-way communications systems including base station/repeater & cassette recorder interface; headphone monitor amp.

CIRCUIT RESEARCH LABS ✓

3204 S. Fair Ln., Tempe, AZ 85282



**ONE OF THE FEW EFFECTS YOU CAN'T DO
ON THE EXPANDED E-FLEX SYSTEM.**

YET. We're working on it, though.

In the meantime, almost anything else you can think of *is* possible. Because we've just expanded the E-FLEX DVE® system with a new Perspective/Rotation accessory. So now, you can rotate images through all three axes. Add depth through perspective. Combine those effects with basic E-FLEX effects including split, compression, mosaic, Multi-move, and trajectory. And store it all on NEC's bubble memory cartridges.

We can't resist noting that our new capabilities make E-FLEX the virtual equivalent of systems costing far more. But more importantly, they make E-FLEX an instrument of almost limitless possibilities. One that takes only a few hours to master—and perhaps a lifetime to fully explore.

What's more, the E-FLEX system is modular. So you can buy it all at once, or start small and add later. And as we develop more capabilities, you'll be able to plug them right in.

To find out what E-FLEX can do now, call NEC at 1-800-323-6656.

By the time you call, we may have perfected the effect in the picture.

NEC

IMAGINE WHAT WE'LL DO NEXT

NEC America, Inc., Broadcast Equipment Division
130 Martin Lane, Elk Grove Village, IL 60007. In Illinois: 312-640-3792

Manufacturers

602 894-0077

SCA generator/processor, AM stereo limiter.
Full line audio processing for AM & FM.
Multiband AGCs, precision limiting.

CLARCOMPUTER SERVICES ✓

Box 100, 111 S. Fifth St., Vandalia, IL 62471
618 283-2325
Radio business automation software.

DAVID CLARK CO.

360 Franklin St., Worcester, MA 01604
617 756-6216
Headphones, intercom systems.

CLEAR-COM INTERCOM SYSTEMS ✓

1111 17 St., San Francisco, CA 94107
415 861-6666
Headphones; RF and hardwired intercoms.
See ad on pg. 158

CLYDE ELECTRONICS LTD. ✓

1660 NW 18 Ave., #201, Delray Beach, FL 33445
305 762-0429
Modular audio mixing consoles; pushbutton news presentation mixer.

CMC TECHNOLOGY CORP. ✓

733 N. Pastoria Ave., Sunnyvale, CA 94086
408 245-3342
Replacement & rebuilt heads for quad & one-inch VTRs; VTR rebuilding service; bulk tape erasers.

CMD, INC. ✓

1552 Laurel St., San Carlos, CA 94070
415 592-8055
Computerized audio routing switchers; compatible digital attenuators.

CMX SYSTEMS, AN ORROX CORP. ✓

3303 Scott Blvd., Santa Clara, CA 95050
408 988-2000
Video editor/controllers, multisource editors.

COASTCOM

2312 Stanwell Dr., Concord, CA 94520
415 825-7500
Video filters. Diplexers; transmit/receive satellite earth stations; remote control systems, RF program subcarrier.



COAXIAL DYNAMICS, INC.

13110 Enterprise Ave., Cleveland, OH 44135
216 267-2233
RF filters, loads, switches, power dividers. RF power meters, wattmeters; frequency monitors, controllers.

COHERENT COMMUNICATIONS, INC. ✓

13756 Glenoaks Blvd., Sylmar, CA 91342
213 362-2566
Mic mixers, portable audio consoles; RF intercoms; electret/condenser, RF & lavalier mics. Time code equipment.

COLORADO VIDEO, INC. ✓

Box 928, Boulder, CO 80306
303 444-3972
Digital still stores; colorizers; slow scan transmitters & receivers. Video sync generators; framestores. Waveform monitors. Distributor of b&w cameras, lenses, lens extenders.

COLOR FILM CORP., VIDEO DIV. ✓

98 Commerce Rd., Stamford, CT 06904
203 327-7270
Video post-production facility; video duplication services.

COLORGRAPHICS SYSTEMS, INC. ✓

5725 Tokay Blvd., Madison, WI 53719
608 274-5786
Digital art/paint systems, weather symbol inserters; weather radar systems, weather information services. Electronic newsroom systems.

COLORTRAN, INC. ✓

1015 Chestnut St., Burbank, CA 91506
213 843-1200

LIGHT FIDELITY

Test, compare and see the difference between light ordinary and light fidelity.

cool light co., inc.

5723 Auckland Avenue, North Hollywood, CA 91601
(213) 761-6116 Telex 194561 LSA-COOL

Circle 151 on Reader Service Card

Lamps, quartz fixtures, stands & rigging, lighting control boards, dimmer packs, diffusion & efx material, cyc lighting; nicad batteries, chargers.

COLUMBIA VIDEO SYSTEMS

The Columbia Building, 1741 Second St., Highland Park, IL 60035
312 433-6010

Equipment rental service; recording studio; video post-production facility; stage, studio rentals; facility turnkey installation; studio, set design.

COLUMBINE SYSTEMS, INC.

7 Jackson Bldg., Level 3, Plaza of the Presidents, Golden, CO 80401
303 279-4000

Complete program automation systems, business automation software for radio & TV.

COMAD, INC.

Box 10667, Pensacola, FL 32504
904 434-9782

Portable production switchers; video DAs; jackfields, patch panels.

COMARK, INC.

Rt. 57 & Hudson Dr., Southwick, MA 01077
413 569-5939

UHF TV transmitters; RF amps, TV exciters; RF attenuators, converters, filters, switches; power dividers; diplexers; modulators; remote control systems; FM antennas; RF demodulators; facility turnkey installations; engineering consultant.

See ad on pg. 53

Field Office:

PA Stuart Kravitz, Dir. of Mktg.,
Comark, P.O. Box 275,
Colmar 18915 215 822-0777

COMEX SYSTEMS

2 Columbia Dr., Amherst, NH 03031
603 889-8564

Digital audio delay.

COMMERCE AIRBORNE, DIV. IFR AVIONICS

16425 Hart St., Ste. 106, Van Nuys, CA 91406

213 782-4801

Aircraft & airborne microwave systems; audio DAs; engineering consultant.

COMPACT VIDEO SERVICES, INC.

2813 W. Alameda Ave., Burbank, CA 91505
213 840-7000

Studio & mobile teleproduction facilities; video post-production facility. Film-to-tape transfers; video & film sound services. Satellite uplink services.

COMPREHENSIVE VIDEO SUPPLY CORP.

148 Veterans Dr., Northvale, NJ 07647
201 767-7990

Manufacturer of mic mixers, character generators, video signal test device, lighting units; distributor of full line of audio & video products.

COMPUCON, INC.

Box 401229, Dallas, TX 75240
214 680-1000

Engineering consultant; earth station site selection.

COMPUTER BUSINESS SYSTEMS

167 Moore Rd., Weymouth, MA 02189
617 337-7799

Business automation hardware.

COMPUTER CABLE CORP.

100 Boxart St., Rochester, NY 14603
716 663-8820

Video broadcast camera cables, hookups, patch panels.

COMPUTER CONCEPTS CORP.

8001 W. 63 St., Shawnee Mission, KS 66202
800 255-6350

Complete program automation systems, radio business automation hardware, radio newsroom computers.

COMPUTER GRAPHICS LAB, INC.

405 Lexington Ave., New York, NY 10174
212 557-5130

Digital art/paint systems, camera/VTR digitizers.

COMPUTER IMAGE CORP.

2475 W. 2 Ave. Ste. 4, Denver, CO 80223
303 934-5801

Electronic animation.

For Your Peace of Mind...

Towers By Stainless!

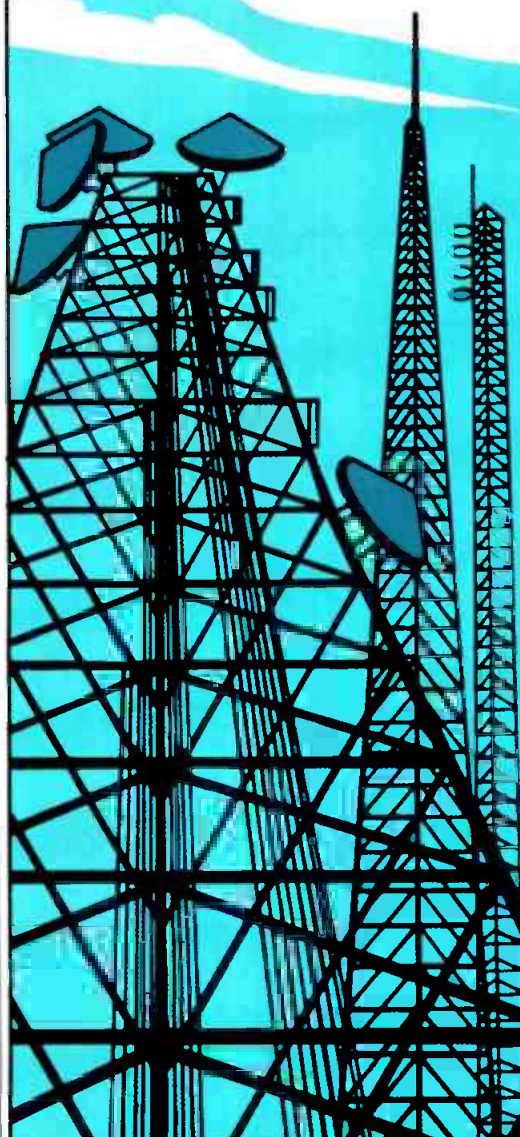

Searching for a reliable tower fabricator? The logical choice is the company with over 35 years and more than 1,000,000 feet of experience—STAINLESS!

Our *one and only* business is designing and building towers for radio, TV, CATV, microwave and radar, and no one understands, better than we do, the importance of dependable engineering and construction.

A large part of being dependable in engineering consists of knowing the best possible ways to meet *specific* needs. For example, the design and fabrication requirements of *tall* towers are far more complex than those of smaller ones. Because we understand that, with all of its implications, we design accordingly and never compromise. As a result, our towers span the world, excelling in performance and durability. And of course, we are fully insured, for your protection.

Stainless... There are many reasons why we are number one.

The Tower
People



Stainless, inc.

North Wales, PA 19454 U.S.A.
Phone: (215) 699-4871
TWX: 510-661-8097

CO183

Circle 152 on Reader Service Card

Manufacturers

COMPUTER LABS, DIV. ANALOG DEVICES, INC. ✓
7810 Success Rd., Greensboro, NC 27409
919 668-9511
Video A/D & D/A converters.

COMPUTER MANAGEMENT SYSTEMS, INC.
See Anacomp

COMPUTER OPERATIONS, INC.
5001-J Forbes Blvd., Lanham, MD 20706
301 459-2100
Real-time video animation.

COMPUTER VIDEO SYSTEMS, INC. ✓
3678 W. 2150 South, Unit 2, Salt Lake City, UT 84120
801 974-5380
Character generators.

COMREX CORP. ✓
Box 269, 60 Union Ave., Sudbury, MA 01776
617 443-8811
Portable audio consoles; ALC, AGC amps; RF intercoms; telco interface equipment; remote pickup equipment. Frequency extenders; wireless microphones.

COMSEARCH, INC. ✓
11503 Sunrise Valley Dr., Reston, VA 22091
703 620-6300

Engineering consultant; earth station site selection; cellular radio; terrestrial microwave frequency planning; MDS services.

COMTECH DATA CORP. ✓
350 N. Hayden Rd., Scottsdale, AZ 85257
602 949-1155
Transmit/receive, receive only, transportable satellite earth stations; SCPC transmit & receive stations; satellite receivers; modulators.

CONCEPT PRODUCTIONS
1224 Coloma Way, Roseville, CA 95678
916 782-7754
Syndicated radio programming.

CONEX ELECTRO SYSTEMS, INC. ✓
1602 Carolina St., Box 1342, Bellingham, WA 98226
206 734-4323
Tone generators, tone sensors; audio switchers; audio monitor, cue amps.

CONNECTRONICS CORP. ✓
652 Glenbrook Rd., Stamford, CT 06906
203 324-2889
Audio wire & cable. Audio signal processors; GBS spring reverb; post-production mixer.

OTIS CONNER PRODUCTIONS
2829 W. Northwest Hwy., Ste. 940, Dallas, TX 75220

214 358-5500
Music library; TV & radio musical ID production packages.

CONRAC, DIV. CONRAC CORP. ✓
600 N. Rimsdale Ave., Covina, CA 91722
213 966-3511
Monochrome, NTSC, RGB video monitors; graphics display monitors.

CONTINENTAL ELECTRONIC (CONTEL)
1620 W. 32 Pl., Hialeah, FL 33012
305 822-1421
Cart player/recorders; LPTV transmitters.

CONTINENTAL ELECTRONICS MFG. CO. ✓
Box 270879, Dallas, TX 75227
214 381-7161
Stereo studio audio consoles. AM, FM transmitters; RF amps, AM stereo exciters, FM exciters, RF filters & loads, diplexers, stereo generators; FM SCA equipment; FM antennas, antenna tuning units; RF phasing network.
See ad on pgs. 144, 168

CONTINENTAL RECORDINGS, INC.
210 South St., Boston, MA 02111
617 426-3131
Audio post-production facility; recording studio; music library; jingles.

Looking for a Distortion Analyser?

Check the little guy on the right...



... the highest performance, most featured and easiest to use audio distortion and noise measurement system in the industry. (and at the lowest price)

amber

Amber Electro Design Ltd.
4810 Jean Talon West
Montreal Canada H4P 2N5
Telephone (514) 735 4105

	Sound Technology 1710A	Hewlett Packard 339A	Amber 3501
Balanced Input & Output	YES	NO	YES*
Termination Switches	NO	NO	YES
IMD: SMPTE/DIN CCIF/IHF Frequency Range	YES* NO 7kHz fixed	NO NO —	YES* YES* 2kHz-100kHz
Automatic Set Level	YES	YES	YES
Automatic Null	YES	YES	YES
Quantity of Filters	3	3	4
Filters user changeable	NO	NO	YES
Continuous frequency tuning	NO	NO	YES
Calibrated output attenuator	YES	YES	YES
Selective voltmeter mode	NO	NO	YES
Battery operation	NO	NO	Option
Options field installable	NO	NO	YES
Residual distortion 1kHz 100kHz	<0.002% <0.35%	<0.0018% <0.032%	<0.0008% <0.006%
Residual noise (80kHz BW)	<8µV	<8µV	<2µV
Maximum output (600 ohm load)	+26dBm	+12dBm	+28dBm
Minimum input THD mode	-18dBm	-28dBm	-28dBm
Auto-null time	<6 secs	not spec	<2 secs
Voltmeter sensitivity (F.S.)	-80dBm	-80dBm*	-120dBm
Size (cubic feet)	1.6	1.0	0.4
Weight (pounds)	25	18	12.5
Price (unbalanced) balanced balanced + IMD	— \$4195 \$5195*	\$2700* — —	\$2100 \$2850* \$3550*
*certain features are options and are included in price stated.			

Circle 153 on Reader Service Card

THE VPR-80/TBC-80 COMBINATION FOR TYPE "C" PERFORMANCE. AT THE LOWEST COST.

\$49,500*

The VPR-80, and its new TBC-80 digital time base corrector, are the key elements in a full-featured, economy-priced one-inch type "C" format VTR system. The VPR-80/TBC-80 package assures you highest performance for under \$50,000.

VPR-80 and TBC-80 together offer you slow motion and still-frame playback with AST™ Automatic Scan Tracking as a standard feature. Other high-performance features include: picture in shuttle up to 100 ips, a built-in editor with keypad for edit point entry and trim, slow-motion playback from stop to 1.5X play speed, an advanced tape transport for playback of spot or two-hour reels, and dual-microprocessor design for comprehensive diagnostics.

The new TBC-80, designed as a companion to the VPR-80, features the very latest in video processing technology to enhance the VPR-80's playback signal. In addition, TBC-80 includes selectable heterodyne processing for use with either 1/2" or 3/4" VTRs.

Compare These Features:

- Flawless slow motion playback (stop to 1.5X play)
- Picture in shuttle
- AST™ standard on all machines
- Powerful frame-accurate editing
- Comprehensive diagnostics with test probe
- Dual-microprocessor design
- Many configurations (including tabletop, rack mount, pedestal, console and full studio console)

The VPR-80/TBC-80. A perfect match. And the price is right.

For more details about the VPR-80/TBC-80 combination, simply contact your local Ampex AVSD sales office: Atlanta 404/451-7112 • Chicago 312/593-6000 • Dallas 214/960-1162 • Los Angeles 213/240-5000 • New York/New Jersey 201/825-9600 • San Francisco 408/255-4800 • Washington, D.C. 301/530-8800

AMPEX

Ampex Corporation • One of The Signal Companies

SETTING
THE FASHION
IN BROADCAST
VIDEO

List price U.S.A.

Circle 154 on Reader Service Card



Manufacturers

CONTROL TECHNOLOGY, INC.
2322 Davie Blvd., Ft. Lauderdale, FL 33312
800 327-4121

Relay & time insertion sequencers, computer automation controllers, complete radio program automation systems, auto time/weather announcers. Facility turnkey installations; engineering consultant; distributor of full line of audio & RF equipment.

CONTROL VIDEO CORP. ✓
578 Division St., Campbell, CA 95008
408 866-7447

Parallel, serial & VITC machine control systems; video editor/controllers, multisource editors; SMPTE time code generators, readers & synchronizers; video business automation hardware.

CONVERGENCE CORP. ✓
1641 McGraw, Irvine, CA 92714
714 549-3146

Video editor/controllers, multisource editors; time code readers; special effects generator.

See ad on pg. 61

Field Offices:

CA Richard Sher, 3575 Cahuenga Blvd.
W., Los Angeles
91403 213 506-7678
NY Meryl Altman, 250 W. 57 St. Suite 815,
New York 10019 212 765-1333

COOL LIGHT CO., INC. ✓
5723 Aukland Ave., N. Hollywood, CA 91601
213 761-6116

Lamps, lighting fixtures.

See ad on pg. 76

COPPERWELD BIMETALLICS GROUP
Robinson Plaza Two, Pittsburgh, PA 15205
412 777-3000
Tower hardware, construction equipment.

CORPORATE COMMUNICATIONS CONSULTANTS, INC. ✓
4250 Veterans Memorial Hwy., Holbrook, NY 11741
516 737-0903

Telecine color correctors; field-by-field, videotape-to-videotape computerized color correctors & luminance compensators.

CORRELLI JACOBS FILM MUSIC
25 W. 45 St., New York, NY 10036
212 586-6673
Audio post-production facility.

COUNTRYMAN ASSOCIATES ✓
417 Stanford Ave., Redwood City, CA 94063
415 364-9988
Electret/condenser, lavalier, modular & capsule mics.
See ad on pg. 166

COX DATA SERVICES ✓
Box 105358, Atlanta, GA 303342
404 843-5555
TV business automation hardware & software.

CREATIVE TECHNOLOGY, INC. ✓
853 Copley Rd., Akron, OH 44320
216 535-5778

Studio & mobile teleproduction facilities; video post-production facility.

CRL AUDIO ✓
3204 S. Fair Ln., Tempe, AZ 85282
602 894-0077
AM & FM compressor/limiters, AGC amps, SCA generators/processors.

CRT—CLARION REMOTE TELEVISION ✓
60 Williamsburg Rd., Evanston, IL 60203
312 674-5850
Mobile teleproduction facilities.

CROSS COMMUNICATIONS CO.
934 Pearl, Suite B, Boulder, CO 80302
303 499-8888
Radio & video business automation hardware; teleconferencing & CATV consulting.

CROSSPOINT LATCH CORP. ✓
95 Progress St., Union, NJ 07083
201 688-1510

Automated video production switchers, post-production switchers; RGB & encoded chromakeyers, downstream keyers; sync & black burst generators. Automated audio consoles; computer automation controllers.
See ad on pg. 18

CROWN INTERNATIONAL, INC. ✓
1718 W. Mishawaka Rd., Elkhart, IN 46517
219 294-5571
Audio preamps, line, monitor, power & dist. amps; parametric & graphic equalizers; computer automation controllers; Pressure Zone (PZM) mics. Tecron computerized audio test systems.



CSI ELECTRONICS, INC. ✓
18248 E. Rogers Cir., Boca Raton, FL 33431
305 994-6511
AM & FM transmitters; status & alarm indicators; stereo & SCA generators.

CSP, INC. ✓
203 Airport Rd., Doylestown, PA 18901
215 345-7386
RF filters, loads, switches, power dividers, diplexers, AM sampling systems.

CUSTOM BUSINESS SYSTEMS, INC. ✓
Box 67, Reedsport, OR 97467
503 271-3684
Radio business automation hardware.

DABURN ELECTRONICS & CABLE CORP. ✓
71-B Oak St., Norwood, NJ 07648
201 768-5400
Solid core, foam dielectric & fiberoptic transmission line. Audio, video, lighting, ac & RF cable, connectors. Hardware tubing and sleeving.

PETER W. DAHL CO., INC.
4007 Fort Blvd., El Paso, TX 79930
915 566-5365
Distributor of transformers.

DALSAT, INC. ✓
Box 1960, Plano, TX 75074
214 578-7561
Transportable earth stations; facility turnkey installations; engineering consultant.
See ad on pg. 143

BILL DANIELS CO., INC. ✓
12113 Johnson Dr., Shawnee, KS 66216
913 631-5707
Catalog of broadcast equipment.

DATA COMMUNICATIONS CORP. (BIAS) ✓
3000 Directors Row, Memphis, TN 38131
901 345-3544
Business automation interfaced master control switchers; video business automation.

DATA PRECISION CORP. ✓
Electronics Ave., Danvers, MA 01923
617 777-1401
Waveform analyzers; dc voltage standards; voltmeters, multimeters, capacitance meters, ohm meters; thermometers.

DATATEK CORP. ✓
1121 Bristol Rd., Mountainside, NJ 07092
201 654-8100
Audio preamps, line, monitor & power amps, DAs. Serial interface video routing switchers; serial interface machine control; black burst generators; pulse amps, video DAs.

DATATRON, INC. ✓
2942 Dow Ave., Tustin, CA 92680
714 554-9970
Video editor/controllers, multisource editors; SMPTE time code generators, readers, synchronizers; proprietary time code system.

DATATRONIX, INC. ✓
2100 Reston Ave., Reston, VA 22091
703 620-5300
Portable, mono & stereo studio, automated, audio for TV mixing consoles; AM & FM compressor/limiters, parametric & graphic equalizers; preamps, line, monitor & power amps, DAs, amp power supplies; slide attenuators; audio patch panels. Audio test signal generators.

DATUM, INC. ✓
1363 S. State College Blvd., Anaheim, CA 92806
714 533-6333
SMPTE time code generators, readers & synchronizers; video time, data insertion devices; digital timers; remote control systems; video editor/controllers; auto tape search systems. Portable video transmitters & rackmount video receivers.

DAVIS & SANFORD CO., INC. ✓
24 Pleasant St., Box 1002, New Rochelle, NY 10802
914 632-1636
Tripods, heads & dollies.

dbx, INC. ✓
71 Chapel St., Newton, MA 02195

DOLBY® NOISE REDUCTION FOR THE 1980'S

SP multi-track unit

360 single-track units

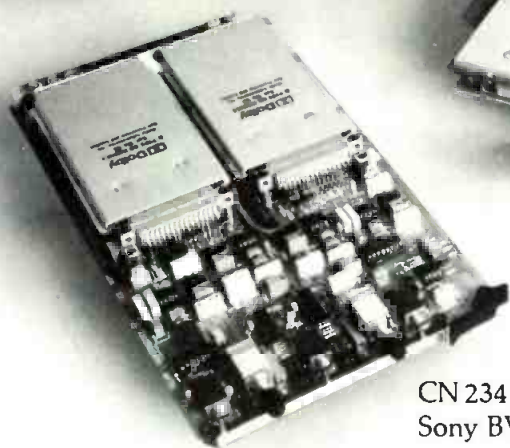

CN 234 for
Sony BVH 2000



CN 221B for
Sony BVH
1000/1100



CN 226 for
Ampex
VPR-2

Dolby noise reduction is keeping pace with today's demand for high-quality sound — everywhere. With the introduction of such products as plug-in modules for VTRs and the SP multi-track unit, it is easier than ever before to protect *all* your irreplaceable audio tracks from hiss, hum, and print-through. From broadcasting to music recording, from video sweetening to motion picture dubbing, Dolby A-type NR reliably continues to fulfill its original promise: effective noise reduction combined with complete signal integrity.

Dolby Laboratories, Inc., 731 Sansome St., San Francisco, CA 94111.
Telephone 415-392-0300. Telex 34409. 346 Clapham Road, London SW9,
Telephone 01-720-1111. Telex 919109. "Dolby" and the double-D symbol
are trademarks of Dolby Laboratories Licensing Corp. 583/5050

 **Dolby**®

Manufacturers

617 964-3210

ALC & AGC amps, AM & FM compressor/limiters, parametric equalizers; audio special effects, noise reduction systems; low-frequency extenders; dB meters.

DELCOM CORP.

6019 S. 66 E. Ave., Tulsa, OK 74145
800 331-5461

Modified Sony U-Matic VCR; facility turnkey installations, engineering consultant, mobile vehicle construction.

DELTA ELECTRONICS, INC.

5730 General Washington Dr., Alexandria, VA 22312
703 354-3350

ALC, AGC amps; AM compressor/limiters; coaxial transfer switches; control panels; RF switches, DA equipment, ATS equipment; frequency modulation controller; meter jacks & plugs; remote sample rectifier circuits; antenna monitor sampling transformers; antenna monitors; RF generators; impedance bridges; status & alarm indicators; common point bridges; power controllers; base current & common point RF metering; remote control systems; pulse reflectometers.

See ad on pg. 163

DELTAMOD CORP.

2823 Ninth St., Berkeley, CA 94710
415 548-4858

Phase control matrixing; audio test tapes; audio noise reduction.

DETERS TOWER SERVICE, INC.

Box 2121, Des Moines, IA 50310
515 274-3171

Tower & antenna installation, maintenance.

DEVLIN PRODUCTIONS, INC.

150 W. 55 St., New York, NY 10019
212 582-5572

Studio & mobile teleproduction facilities; video post-production facility.

DE WOLFE MUSIC LIBRARY INC.

25 W. 45 St., New York, NY 10036
212 586-6673

Production music library & sound effects.

DEXCEL, INC.

2285C Martin Ave., Santa Clara, CA 95050
408 727-9833

Receive only satellite earth stations; LNAs, LNA down converters.

DICTAPHONE CORP.

120 Old Post Rd., Rye, NY 10580
914 967-7300

Tape-based loggers.

DIELECTRIC COMMUNICATIONS

Tower Hill Rd., Raymond, ME 04071
800 341-9678

RF loads; RF power meters & wattmeters; RF switches, rectangular waveguides; FM filters.

DIGIMAX INSTRUMENTS CORP.

5625 Kearny Villa Rd., San Diego, CA 92123
619 569-6582

Frequency counters & accessories.

DIGITAL BY DICKINSON

B547-9 Westinghouse Plaza, Bloomfield, NJ 07003

201 429-8996

Digital audio equipment rentals.

DIGITAL SERVICES CORP.

825 NW 13 St., Gainesville, FL 32601
904 377-8013

Master control automation systems. Digital video effects processors.

DIGITAL VIDEO PRODUCTIONS

62 S. Franklin St., Wilkes-Barre, PA 18773
717 824-1161

Studio & mobile teleproduction facilities; video post-production facility.

DIGITAL VIDEO SYSTEMS

716 Gordon Baker Rd., Willowdale, Ont., M2H 3B4, Canada

416 499-4826

Digital TBCs, dual-channel TBCs, frame & field synchronizers; dropout compensators; comb decoders; A/D & D/A converters; phasers; encryption/decryption satellite transmission systems.

See ad on pg. 137

DIGIVISION

11722 Sorrento Valley Rd., San Diego, CA 92121

619 481-9933

High resolution digital video convertor for display devices.

DI-TECH, INC.

48 Jeffry Blvd., Deer Park, NY 11729
516 667-6300

Computer automation controllers; audio DAs. Parallel & serial interface routing switchers; video signal, cable equalizers; video DAs, pulse amps.

See ad on pg. 109

DOCUVID

220 E. 23 St., New York, NY 10010
212 532-6903

ENG production services, facilities. Satellite uplink services.

DOLBY LABORATORIES

731 Sansome, San Francisco, CA 94111
415 392-0300

Audio noise reduction systems.

See ad on pg. 81

Field Office:

UK Dolby Laboratories Inc.,
346 Clapham Rd.,
London SW9 . . Telephone: 01-720-111/
Telex: 919109

DORROUGH ELECTRONICS

5221 Collier Pl., Woodland Hills, CA 91364
213 999-1132

AM & FM compressor/limiters; LED audio loudness indicators.

DRAKE-CHENAULT ENTERPRISES, INC.

Box 1629, Canoga Park, CA 91304
213 883-7400

Syndicated radio programming; engineering consultant.

R.L. DRAKE CO.

540 Richard St., Miamisburg, OH 45342
513 866-2421

Video satellite receivers; low noise amps for video satellite reception.

DUART VIDEO

245 W. 55 St., New York, NY 10019
212 757-3681

Video post-production facility.

DUBNER COMPUTER SYSTEMS

158 Linwood Plaza, Fort Lee, NJ 07024
201 592-6500

Telecine color correctors; character generators; animation systems; art/paint systems; bit pad & camera/VTR digitizers, weather symbol inserters; color correctors. Engineering consultant.

See ad on pg. 33

DUDKOWSKI-LYNCH ASSOC.

150 Shoreline Hwy., Bldg. D, Mill Valley, CA 94941

415 332-5825

Teleproduction & video post-production facilities.

VICTOR DUNCAN, INC.

2659 Fondren, Dallas, TX 75206
214 369-1165

Video & film production equipment rental, sales & service.

See ad on pg. 185

Field Offices:

IL Bob Coleman, 661 N. La Salle,
Chicago 60610. 312 943-7300
MI Ginny Hart, 32380 Howard St.,
Madison Hts. 48071 . . . 313 589-1900

DUNCAN ELECTRONICS

2865 Fairview Rd., Costa Mesa, CA 92626
714 545-8261

Slide attenuators.

DYMA ENGINEERING

367 Main SW, Box 1535, Los Lunas, NM 87031

505 865-6700

Audio preamps, line, monitor & power amps, DAs; equalizers & filters; special effects & reverb; mono, stereo & audio for TV mixing consoles; dynamic mics; patch panels; RF switchers; surge protectors. Equipment rental, radio & TV studio construction; mobile van construction.

DYNACOM ELECTRONICS, LTD.

590 Commerce Park Dr., Ste. 125, Marietta, GA 30060

404 428-3100

Tape duplicators, PTV scramblers; MDS downconverters. Facility turnkey installations.

DYNAIR ELECTRONICS, INC.

5275 Market St., San Diego, CA 92114
619 263-7711



Between You And Everyone Else
WE'RE THE ONE.



TW INTERCOM SYSTEM

A high performance conference-line communications system featuring over 25 different components and accessories that allow an almost infinite variety of system configurations. It's universally designed for demanding applications in teleproduction and broadcast as well as industrial and commercial installations.

Standard TW features include: up to 75 user stations on line with minimum loading, powerful headphone amplification, carbon/dynamic headset capability, mic-level limiting, and two-channel operation on standard microphone cable. Sophisticated circuitry permits 12-volt power operation, two-, three-, and four-wire line operation. A series of versatile options are also available to meet virtually all special requirements.



SERIES 800

The 802 Master Station is a unique micro-processor-assisted communications network providing 22 independent signal paths operating in up to six modes. It offers an impressive array of features including intercom, squawk, IFB/SA, station iso, and signalling. An intelligent combination of hardware and software program-mability allows the user to conveniently structure an individualized operating format. Since the 802 is completely self-contained, it does not require space-consuming central electronics. Currently used in teleproduction, broadcast, theatre, security, aerospace and other industries, the 802 is both powerful and versatile enough to meet almost every communications requirement.



SERIES 4000 IFB SYSTEM

A one-way communications system created especially to meet the critical requirements of the television broadcast industry. This "program interrupt" system is used primarily to cue on-air talent. It provides program source material to the person on camera that can be interrupted with messages from the producer or director. Its modular building-block design allows the user to configure a system to meet specific requirements. A typical system combines User Stations, Central Electronics, and Control Stations. An essential broadcast tool.



SERIES 400 AMPLIFIERS

Application, performance, and reliability have all been carefully designed into the Series 400. The results: outstanding sound and unique versatility.

MODEL 405 PROFESSIONAL PHONO PREAMPLIFIER: High performance for broadcast stations and high-quality commercial installations.

MODEL 410 10-WATT MONITOR AMPLIFIER: A compact unit designed to power loudspeakers and headphones.

MODEL 414 DISTRIBUTION AMPLIFIER: High performance 1x4 audio D.A. with balanced input and four individually amplified transformer balanced outputs.

MODEL 416 DISTRIBUTION AMPLIFIER: Expanded version of the 414 with six outputs.

MODEL 444 DUAL TWO-CHANNEL BUFFER AMPLIFIER: Provides the necessary electronic interface between +8dBm balanced and -10dBv unbalanced circuits.

MODEL 465 MICROPHONE PREAMPLIFIER: A single-channel wideband preamp with transformer-balanced input and output.

RTS
Systems
INC. A COMPACT VIDEO COMPANY

RTS SYSTEMS, INC. • PROFESSIONAL INTERCOMMUNICATIONS • PROFESSIONAL AUDIO PRODUCTS
 1100 WEST CHESTNUT STREET • BURBANK, CA 91506 • 213/843-7022 • TWX 910-498-4987 • TELEX 194855

Circle 156 on Reader Service Card

www.americanradiohistory.com

Manufacturers

Audio DAs; audio switchers, manual, automated & business automation interfaced master control switchers; serial interface routing switchers; video signal, cable equalizers; pulse amps, video DAs; RF modulators.

DYNATECH DATA SYSTEMS ✓
7644 Dynatech Ct., Springfield, VA 22153
703 569-9000
Coaxial & twin axial patching equipment.

EAST COAST VIDEO SYSTEMS, INC.
548 Broadway, New York, NY 10012
212 431-7453
Engineering consultant; studio, set design.

EASTMAN KODAK CO., MOTION PIC. & AV DIV. ✓
343 State St., Rochester, NY 14650
716 724-4000
Motion picture film, projectors, film processors.

ECHOLAB, INC. ✓
175 Bedford Rd., Burlington, MA 01803
617 273-1512
Compact studio/mobile & automated production switchers; post-production switchers; serial editing interface.

ECONCO BROADCAST SERVICE, INC.
1318 Commerce Ave., Woodland, CA 95695

916 662-7553
RF power tubes, vacuum tubes.

EDCOR
16782 Hale Ave., Irvine, CA 92714
714 556-2740
RF intercom systems; dynamic, wireless, lavalier mics; audio preamps; line, monitor & power amps; video signal multiplexers.

EDITEL/LA ✓
729 N. Highland, Hollywood, CA 90038
213 931-1821
Studio & mobile teleproduction facilities; video post-production facility.

EDITEL/CHICAGO ✓
301 E. Erie, Chicago, IL 60611
312 440-2360
Studio & mobile teleproduction facilities; video post-production facility.

EDITEL/NEW YORK ✓
222 E. 44 St., New York, NY 10017
212 551-8400
Studio & mobile teleproduction facilities; video post-production facility.

EECO, INC. ✓
1601 E. Chestnut Ave., Santa Ana, CA 92701
714 835-6000
Electronic audio editors; SMPTE time code synchronizers. Longitudinal and VITC time code generators; computer-controlled video

editing systems; SMPTE time code generators/readers; proprietary time code systems.

EEG ENTERPRISES, INC. ✓
1 Rome St., Farmingdale, NY 11735
516 293-7472
SMPTE time code generators, readers; video source identification; closed captioning, teletext.

EELA AUDIO ✓
Box 786, Bremerton, WA 98310
206 275-5009
Mic mixers; portable, mono & stereo, & audio for TV mixing consoles.

EEV, INC. ✓
7 Westchester Plaza, Elmsford, NY 10523
914 592-6050
Camera pickup tubes; RF power tubes, UHF TV klystrons. Digital clocks; vacuum tubes, rectifiers, surge protectors.
[See ad on pgs. 21, 88-89](#)

Field Offices:
GA Suite 100E, 15 Dunwoody Park, Atlanta 30338 404 394-9201
IL 2073 Arleen Ct., Schaumburg 60194 312 843-8417
NY 250 Hamilton Dr., Snyder 14226 716 839-5959
TX P.O. Box 170657, Arlington 76017 214 837-2464
WA 19001 40 Pl. NE, Seattle 98155 206 363-2200

4 Models—8 and 10 mixer dual stereo with rotary or linear faders • Transformer Balanced Inputs and Outputs • 3 Inputs Per Mixer—internal pads allows mic/line selection on the same mixer • Two 4-Input Auxiliary Input Selectors—may be assigned to any mixer • Pre-fader Pushbutton Cue—in addition to normal CCW fader cue position • LED Status Indicators—color coded to aid in instant identification of function selectors • Momentary or Continuous Remote Control Contacts—internally selectable, also controls optional digital timer reset/start • Full Metering Capability—two meters standard, up to four meters and/or digital clocks and timers optionally available, all meters provided with LED peak indicators • Gain Selectable Microphone Preamps—provided with center tap access for phantom condenser microphone power, processor input/output port with buffer amplifier for outboard compressors, limiters, etc. • Programmable Muting Logic—internal pin-programmed matrix allows any selection of monitor and cue muting for the first five mixer positions • Pushbutton Aural Phase Test • Announcer's Microphone Intercom-Air Selector • Full Dual Channel Operation—-independent program and audition assignment push-buttons • Five Monitor Driver Outputs—four muted, one non-muted • All Mixers Switch-Selectable to Mono or Stereo • Ground-Plane Techniques Used Throughout for Increased RF Immunity • Selectable Internal or External Master Level Controls • Accessories and Options—mono mixdown, high impedance (cassette) line input plug-ins, reference oscillator/line input plug-in, additional microphone input plug-ins, digital clock, digital timer, linear faders.



LPB® **citation series** Everything you want in an audio console
LPB Inc. • 28 Bacton Hill Road • Frazer, PA 19355 • (215) 644-1123
Manufacturers and Distributors of Broadcast Equipment since 1960
© 1981 LPB Inc.

Telex: 703000
ESL: 62184590

Circle 157 on Reader Service Card

The 6120 is an original — not just a warmed-over copy of some other duplicator. It's brand new, and offers you more time-saving, quality features in one compact package than any other duplicator on the market today.

FAST

16-to-1 copying speeds from reel to cassette. Reel modules run at either 60 or 120 ips and cassettes run at 30 ips, which means you can copy up to eleven one hour programs in less than two minutes!

EFFICIENT

The 6120 accepts either 7" (178 mm) or 10½" (267 mm) reels, so you don't waste time rethreading from one reel format to another. All key setups and adjustments are made easily from the front of the system, so you don't have to waste time moving or disassembling the 6120. Accurate monitoring and precise adjustments of audio and bias levels are made possible even at high speeds, because of quick response LED level indicators. All cassette slaves are independent, so a jammed tape won't shut down the entire system, and a LED indicator warns you of an incomplete copy in case a cassette tape jams or ends before the master.

If you want good duplicates start with a great original

The new Telex 6120



You can produce eleven C-60 cassette tapes in less than two minutes!

EASY AUTOMATED OPERATION

The 6120 practically runs itself. The system features automatic end-of-tape stop and auto-recue on the reel master, and a choice of manual or auto-rewind on the cassette master, providing virtually uninterrupted operation. Changes in equalization are made automatically when you change speeds on the reel master, thereby reducing setup time and avoiding errors.

EXPANDABLE

The modular, building block concept lets you buy just what you need today and expand the system to meet your growing needs tomorrow. Modules simply plug together. There's no need to add people or space as the system grows, because the 6120 is so compact that even a full system can be operated by one person.

QUALITY TRADITION

For over 20 years now, Telex has been the choice of those who are fussy about the quality of their duplicate tapes. The brand new 6120 is made in the U.S.A. in the Telex tradition of quality, so parts and service are always available. To learn more about the 6120, write today for complete specifications and production capabilities. While you're at it, make an appointment to see our special 6120 video tape presentation entitled "Beating Real Time".



TELEX COMMUNICATIONS, INC.

9600 Aldrich Ave. So., Minneapolis, MN 55420 U.S.A.
 Europe: Le Bonaparte—Office 711
 Centre Affaires Paris-Nord, 93153 Le Blanc-Mesnil, France.

Call Toll Free in U.S. 800-828-6107
 In Minnesota Call (612) 884-7367

- Send me literature
- I want an appointment to see the special 6120 video tape presentation.

Mail coupon to:
 Telex Sales Information Center
 P. O. Box 480 Cathedral Station
 Boston, MA 02118

Name _____

Title _____

Company/Organization _____

Address _____

City _____ State _____ Zip _____

Best time to contact _____

Phone No. _____ B/ME 8-83

Circle 158 on Reader Service Card

Manufacturers

EG&G

35 Congress St., Salem, MA 01970
617 745-3200
Tower lighting.
See ad on pg. 93

EIDSON ELECTRONIC CO.

Box 3751, Temple, TX 76501
817 773-3901
Frequency control crystals for AM, FM & TV transmitters.

EIGEN VIDEO

Box 848, Nevada City, CA 95959
916 272-3461
Video disc action recorder, video animation controller; framestores, video noise reducers; analog still storage.

ELCOM BAUER

6199 Warehouse Way, Sacramento, CA 95826
916 381-3750
Mono audio consoles; single-deck cart player/recorders; ALC, AGC amps; AM & FM compressor/limiters. AM & FM transmitters; AM & FM exciters; antenna tuning units.



ELECTOR USA

5128 Calle del Sol, Santa Clara, CA 95050
408 727-1506
NTSC & RGB color video monitors. SMPTE time code synchronizing systems; PPM meters; SMPTE time code readers, generators; video monitors; graphic color displays.
See ad on pg. 1
Field Office:
NJ Chris Golson, 30 Chapin Rd.,
P.O. Box 699, Pinebrook
07058 201 888-0584

ELECTRO CONTROLS

2975 S. 300 West, Salt Lake City, UT 84115
801 487-9861
Lighting control boards, dimmer packs, diffusion & efx material, cyc lighting.

ELECTROHOME, LTD.

809 Wellington St., N. Kitchener, Ont., N2G 4J6 Canada
519 744-7111
Color & high-resolution monochrome monitors; large screen data graphics and video monochrome & color projectors. Earth station receivers and navigators.

ELECTRO IMPULSE, INC.

116 Chestnut St., Red Bank, NJ 07701
201 741-0404
RF loads; RF power meters, wattmeters, calorimeters.
See ad on pg. 158

ELECTRONICS DIVERSIFIED, INC.

1675 NW 216, Hillsboro, OR 97123
503 645-5533
Lighting control boards, dimmer packs; connectors & patch panels.

ELECTRONIC FIELD PRODUCTIONS

725 University Dr., Arlington Heights, IL 60004
312 577-1811
Mobile teleproduction facility; video post-production facility.

ELECTRO & OPTICAL SYSTEMS, LTD.

31 Progress Ct., Scarborough, Ont., M1G 3V5 Canada
416 439-9333
SMPTE time code synchronizing systems; PPM meters; SMPTE time code readers, generators; video monitors; graphic color displays.

ELECTRO & OPTICAL SYSTEMS, LTD. U.S.

See Elector USA

ELECTRO SOUND, INC.

160 San Gabriel Dr., Sunnyvale, CA 94086
408 245-6600
Audio tape duplicators; replacement audio heads, alignment & tension gauges; audio cassettes & test tapes, tape loaders; splicing blocks & tape; audio test signal generators.

ELECTRO-VOICE, INC.

600 Cecil St., Buchanan, MI 49107
616 695-6831
Mic mixers; portable & studio stereo audio consoles; graphic equalizers, analog special effects & reverb, mechanical reverb; monitor speakers; dynamic, electret/condenser, shotgun, lavalier, modular & capsule mics; mic stands, booms & dollies; line, monitor & power amps.
See ad on pg. 155
Refer to Reps/Distributors section
Field Office:
CA Electro-Voice West,
8234 Doe Ave.,
Visalia 93277 209 651-7777

ELLIS TOWER

Box 23217, Fort Lauderdale, FL 33307
305 566-6432
Turnkey installations for radio & TV; communications towers; cable TV earth stations, towers, & buildings.

EMCEE BROADCAST PRODUCTS

Box 68, White Haven, PA 18661
800 233-6193
VHF & UHF transmitters; translators & LPTV equipment; MDS & ITFS transmitters.

EMCOR

1600 Fourth Ave. N.W., Rochester, MN 55901
507 289-3371
Cabinets, racks, & modules for all rack equipment.

EMERGENCY ALERT RECEIVER, INC.

1 W. 30 St., New York, NY 10001
212 695-4767
EBS two-tone systems; FM SCA equipment.

ENCLOSURE CORP.

4529 Adams Circle,

Cornwells Heights, PA 19020
215 638-9550
19-inch equipment racks.

ENERLITE

550 Stephenson Hwy., Troy, MI 48084
313 589-0085
Nicaid batteries and power packs.

E-N-G CORP.

1009-A Shary Circle, Concord, CA 94518
415 798-4060
ENG microwave-equipped mobile vehicles with telescoping roof masts.

ENG HELICOPTER SATELLITES, LTD.

9919 Carter Rd., Bethesda, MD 20817
301 469-8109
Helicopter-mounted camera stabilizing systems; complete helicopter microwave & communication system rentals.

ENGINEERING LAB, INC., VIDEO SPECIALTIES DIV.

11535 Sorrento Valley Rd., San Diego, CA 92121
619 450-1067
Parallel, serial & VITC machine control systems; custom remote control.

THE ENSTROM HELICOPTER CORP.

Box 277, Menominee, MI 49858
906 863-9971
ENG microwave-equipped helicopters.

ENTERPRISE ELECTRONICS CORP.

Box 1216, Enterprise, AL 36330
205 347-3478
Weather radar systems.

ENVIRONMENTAL CONTAINER SYSTEMS, INC.

Box 188, Grants Pass, OR 97526
503 476-8871
Empty videotape reels & containers; foam insert & rack configuration transportation cases; 19-inch equipment racks.

ENVIRONMENTAL SATELLITE DATA

5200 Auth Rd. World Weather Building, Suitland, MD 20746
301 423-2113
Supply digital satellite imagery & conventional weather graphics and computer terminal display systems.

ESC ELECTRONICS CORP.

534 Bergen Blvd., Palisades Park, NJ 07650
201 947-0400
Filters, delay lines.

ESE

142 Sierra St., El Segundo, CA 90245
213 322-2136
LED audio level indicators; SMPTE time code readers, generators; proprietary time code systems. Digital clocks, master & slave clocks, timers, time distribution equipment.
See ad on pg. 45

ESPN

ESPN Plaza, Bristol, CT 06010

JVC engineers another breakthrough in video cameras.

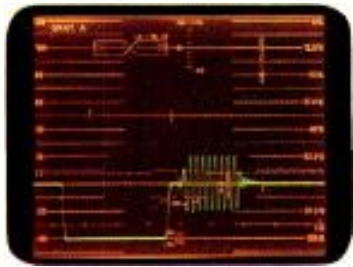

JVC, a world leader in miniaturization of electronic components, brings you a new option at the highest level of production quality cameras.

ProCam™ Video Cameras!

They're available in two models: ProCam 950 with LOC diode gun Plumbicon* tubes, and ProCam 900 with LOC diode gun Saticon** tubes.

Never before has so much been put into cameras this size. One look at the double-sided circuit boards will give you an idea of how packed with features they are. And you'll see the great results every time you use them.

You'll see great picture quality: Better than 600 Lines Resolution... Signal-to-Noise Ratio of 58dB.

You'll see great performance features: Auto-Shift Registration... Automatic White and

Black Balance... Corner Registration Correction... Matrix Masking... Auto Centering... Flare Compensation... Focus Wobbling... Auto Black Level Stabilization... Zebra Stripe Video Level Indicators in Viewfinder... 2H Vertical Contour Correction... Split Field Color Bar Generation... f/1.4 Prism Optics With Built-In Quartz Filter... Stable RS-170A Sync Output with Color Frame.

You'll see great convenience features: Light Weight... A Pickup Tube Protection Circuit... Compact, Solid Aluminum-Diecast Body... Memory Back-Up... Preheating Circuit... Video Recorder Power Save Circuit... LED Viewfinder Indicators... Digital H/V Variable Blanking. You'll see traditional JVC value... traditional JVC



reliability... traditional JVC flexibility. And you'll see them in distinctly untraditional cameras... but cameras whose advanced circuitry is in the unique JVC tradition.

ProCam™

For more information, call toll-free

1-800-JVC-5825

Or write: JVC COMPANY OF AMERICA
Professional Video Division, Dept. BME 8/83
41 Slater Drive, Elmwood Park, NJ 07407
JVC CANADA, Scarborough, ONT.

**Someday
others will build
3-tube color
cameras like JVC.
Not yet!**

©1983 JVC COMPANY OF AMERICA

ProCam is a trademark of US JVC CORP

*Plumbicon™ is a registered trademark of North American Philips Corp
**Saticon™ is a registered trademark of Hitachi Denshi Ltd



JVC®

JVC COMPANY OF AMERICA
Professional Video Division

Circle 159 on Reader Service Card

The definition of the best color camera

No matter how you define your color camera needs, you will want to be certain you have chosen the best tube for the job. And no technical appraisal can be complete without EEV Leddicons.

Highest picture quality

Lag or smearing under low-light conditions is a common effect with most tubes - but less with EEV Leddicons! Instead of the twin-light pipe used by some competitors, Leddicons incorporate a unique light bias arrangement with a 10-hole and sintered quartz diffusing disc system for minimal shading. Differential lag is minimised by balancing the response speeds of the green, red and blue channels; so a football in flight will always look like a football - not a flying saucer! Light biasing is variable on 30mm and 25mm Leddicons. On 30mm types, biasing is integral so there is no need for a clumsy adaptor.

High resolution

EEV is the only manufacturer to make three different target layers to optimise resolution for each color channel. The advantage of this unique feature can be clearly seen in the Leddicon's much better performance.

Faithful color imagery

Faithful color imagery is all about reproducing what the eye sees. And that is exactly what Leddicons do. Extended reds have a precisely-engineered response and a matched infra-red filter is incorporated to provide cut-off where you want it.

Reduced highlight image retention

Highlight image retention can be a production team's nightmare - the wrong choice of tube and highly polished orchestra instruments can end up looking like the aftermath of an aerobatics display. With EEV Leddicons, the problem is minimised by a unique target manufacturing process. The result is you can rely on Leddicons, even in the very difficult extended red channel where other tubes are simply unable to cope.

Better tube quality - plus longer life

At long last a manufacturer who is prepared to talk about blemishes - but then we know Leddicons average less spotting than other tubes! The secret lies in the fact that all Leddicons must satisfy the most exacting manufacturing, testing and quality control standards. These not only preclude loose particles from the inside of the tube but also ensure longer tube life.

Optimised geometry and registration

The optimised electron optical design of Leddicon ensures the best possible geometry without distortion. Registration too is equally distortion free - we can, in fact, supply computer-matched sets for all three channels.

LEDDIC

Unique anti-microphonic features

Nothing tests a tube more rigorously than the range of frequencies generated by an orchestra. With EEV's unique anti-microphonic mesh assembly, Leddicons provide the cleanest pictures - even from cameras operating in areas of high ambient acoustic noise.



FOR FURTHER INFORMATION ON LEDDICONs, CALL US TODAY.

IN USA Toll free 800 431 1230 (except for NY State).

EEV Inc Corporate Office, 7 Westchester Plaza, Elmsford, NY 10523.

Tel: 914 592 6050. Telex: 6818096. **Mid. Western Sales Office**, 2073 Arleen Court

Schaumburg, IL 60194. Tel: 312 843 8417. **North-Eastern Sales Office**, 250 Hami

Drive, Snyder, NY 14226. Tel: 716 839 5959. **Southern Sales Office**, Route 1, Ann

TX 75003. Tel: 214 837 2464. **South-Eastern Sales Office**, Suite 100E,

15 Dunwoody Park, Atlanta, GA 30338. Tel: 404 394 9201.

Tri-State Sales Office, 7 Westchester Plaza, Elmsford, NY 10523. Tel: 914 592 61

Western Sales Office, 19001 40th Place, N E Seattle, WA 98155. Tel: 206 363 22

IN CANADA EEV Canada Ltd, 67 Westmore Drive, Rexdale Ontario M9V 3Y6.

Tel: 416 745 9494. Telex: 06 989 363.

REST OF THE WORLD EEV, Waterhouse Lane, Chelmsford, Essex CM1 2QU, Engl

Tel: 0245 61777. Telex: 99103.

Circle 160 on Reader Service Card

tubes in the world.

First for customer service

EEV is not only concerned with manufacturing the best tubes but also ensures the best delivery and after-sales service. Our reputation in this respect, like that of our Leddicons, is second to none.

To serve the needs of our broadcast customers in the USA and Canada best, we sell direct from our centers in New York and Toronto where we maintain a large inventory as well as full test facilities.

When you add up all the facts about EEV Leddicons, there is only one conclusion - namely, the definition of the best tubes for your camera. But don't leave it at that. Next time specify Leddicons for your new equipment and as replacements. Then find out what that definition really means in practice.

LEDDICONS[®]

Comprehensive range

EEV Leddicons are specified throughout the world for virtually every type of studio, EFP and ENG camera. The range covers 30mm (1 1/4 in), 25mm (1 in), 18mm (3/4 in) and 12mm (1/2 in) sizes. And the comprehensive choice of front- and rear-loading types includes diode gun, low output capacitance (LOC) diode gun, triode gun and tetrode gun highlight overload protection (HOP).

EEV Leddicons are fully interchangeable in most types of camera including:

BCC10/20/21	HL79/81/83	MNC80	TC80/85
BVP300/330	HK312/322	MKVIII/IX	TK47
CEI310	KCU/KCK40	SK91/96	TK76
FOTON 1	LDK5/15/25	SK110	TTV1515/1516

®Leddicon is the Registered
Trademark of EEV Lead Oxide Camera Tubes



EEV Camera Tubes 

Manufacturers

203 584-8477

Studio & mobile teleproduction facilities; video post-production facility.

EUMIG (U.S.A.), INC.

Lake Success Business Pk., 225 Community Dr., Great Neck, NY 11020
516 466-6533

Audio preamps, line & monitor amps, amp power supplies; audio cassette decks. Cine cameras.

EUREKA TELEPRODUCTION CENTER

1250 San Carlos Ave., San Carlos, CA 94070
415 595-3200

Studio & mobile teleproduction facilities; video post-production facility; recording studio.

EVENTIDE CLOCKWORKS, INC.

265 W. 54 St., New York, NY 10019
212 581-9290

ALC & AGC amps, digital audio special effects, digital delay & reverb, time compression/expansion, real-time audio analyzers. Video time compression/expansion; digital video effects processors. Audio spectrum analyzers.

EXCALIBUR INDUSTRIES

12427 Foothill Blvd., Lake View Terrace, CA 91342

213 899-2547

Foam insert & rack configuration transportation cases.

EXCALIBUR VIDEO SYSTEMS, INC.

4015 Wilshire Blvd., Los Angeles, CA 90010
213 384-5175

Studio & mobile teleproduction facilities; video post-production facility.

EXR

3373 Oak Knoll Dr., Brighton, MI 48116
313 227-6122

Audio processing exciter.

FAIRCHILD CAMERA & INSTRUMENT/CCD IMAGING DIV.

4001 Miranda Ave., Palo Alto, CA 94304
415 493-3100

Video delay lines; CCD line sensor for telecines.

FANTASEE LIGHTING

404 N. River, Ypsilanti, MI 48197
313 482-6565

Lighting, studio & set design; lighting equipment rental service; stage, studio rentals; engineering consultant.

FAROUDJA LABORATORIES, INC.

946 Benicia Ave., Sunnyvale, CA 94086
408 245-1492

Video decoders, comb filter decoders; video noise reducers, image enhancers, color correctors.

FARRTRONICS, LTD.

151 Bentley St. Unit #1, Markham, Ont., L3R 3X9 Canada
416 475-6720

Hardwired intercom systems; audio & video

patch panels; audio DAs; dc-controlled audio console.

FAX PRODUCTIONS

4924 Hampden Ln., Bethesda, MD 20814
301 652-7800

Studio & mobile teleproduction facilities; video post-production facility.

F&B/CECO, INC.

315 W. 43 St., New York, NY 10036
212 974-4600

Hajnal snorkel lens; tripods, heads; lamps, HMI & CSI fixtures, quartz fixtures, lighting stands & rigging, diffusion & efx material, cyc lighting; nicad batteries & chargers, generators; splicing blocks, tape; mic stands, booms & dollies; lens filters; audio & lighting cable; equipment rental service.

FIBERBILT

601 W. 26 St., New York, NY 10001
212 675-5820

ATA flight foam insert cases.

FIDELIPAC CORP.

Box 808, Moorestown, NJ 08057
609 235-3900

Tape alignment & tension gauges; audio carts, test tapes, empty reels & carts, bulk erasers, cart labels; audio splicing blocks & tapes; pickup arms, phono cartridges; dynamic, electret/condenser, shotgun & lavalier mics; mic stands, booms & dollies; studio warning lights; wow & flutter meters; tape storage units; back lubricated tape.

See ad on pg. 136

FILM/VIDEO EQUIPMENT SERVICE CO, INC.

1875 S. Pearl St., Denver, CO 80210
303 778-8616

Equipment rental service; wide angle lens attachments.

FINNTEK, LTD.

12797 S. 2230 West, Box 235, Riverton, UT 84065

801 254-6398

Mono, stereo & audio for TV mixing consoles; audio & video test signal generators.

IMERO FIORENTINO ASSOC., INC.

44 W. 63 St., New York, NY 10023
212 246-0600

Lighting, studio & set design services; teleconferencing.

FIRST COMMUNICATIONS, INC.

3095-H Presidential Dr., Atlanta, GA 30340
404 458-0901

Studio & mobile teleproduction facilities; video post-production facility.

FIRSTCOM BROADCAST SERVICES, INC.

13747 Montfort Dr., Dallas, TX 75240
214 934-2222

Music library; music & ID production, commercial production.

FISHER BERKELEY CORP.

5800 Christie Ave., Emeryville, CA 94608
415 655-9696

Handwired intercom systems.

FITZCO SOUND, INC.

204 N. Midhiff, Midland, TX 79701
915 684-0861

Audio equipment rental service; audio engineering consultant.

FLASH TECHNOLOGY CORP. OF AMERICA

55 Lake Street, Nashua, NH 03060
603 883-6500

High-intensity beacons for towers.

FLORIDA PRODUCTION CENTER

150 Riverside Ave., Jacksonville, FL 32202
904 354-7000

Studio & mobile teleproduction facilities; video post-production facility.



JOHN FLUKE MFG. CO., INC.

Box C9090, MS25DC, Everett, WA 98206
206 356-5400

RF test signal generators; voltmeters, multi-meters, dB meters.

FOR-A CORP.

49 Lexington St., W. Newton, MA 02165
617 244-3223

Character generators, screen drawing systems, colorizers & title keyers; SMPTE time code generators/readers; sync, black burst & color bar, safe title area & countdown generators; TBCs, frame synchronizers, image & color enhancers; video DAs; timers.

See ad on pg. 49

Field Office:

CA 1680 N. Vine St., Los Angeles
90028 213 467-8412

FOROX CORP.

393 West Ave., Stamford, CT 06902
203 324-7400

Animation cameras & stands.

FORTEL, INC.

6649 Peachtree Industrial Blvd., Norcross, GA 30092

404 449-4343

Digital TBCs, frame synchronizers, noise reducers, image enhancers, error correctors. Dist. of Faroudja image enhancement system.

FORT WORTH TOWER CO.

1901 E. Loop 820 S., Box 8597, Fort Worth, TX 76112

817 457-3060

Towers, masts, tower hardware & construction equipment, tower lighting; receive only & transportable satellite earth stations.

FOSTEX CORP. OF AMERICA

15431 Blackburn Ave., Norwalk, CA 90650
213 921-1112

Division Radiodiffusion Télévision - Laboratoire Général des Télécommunications.

CAPABILITY AT ALL POWERS

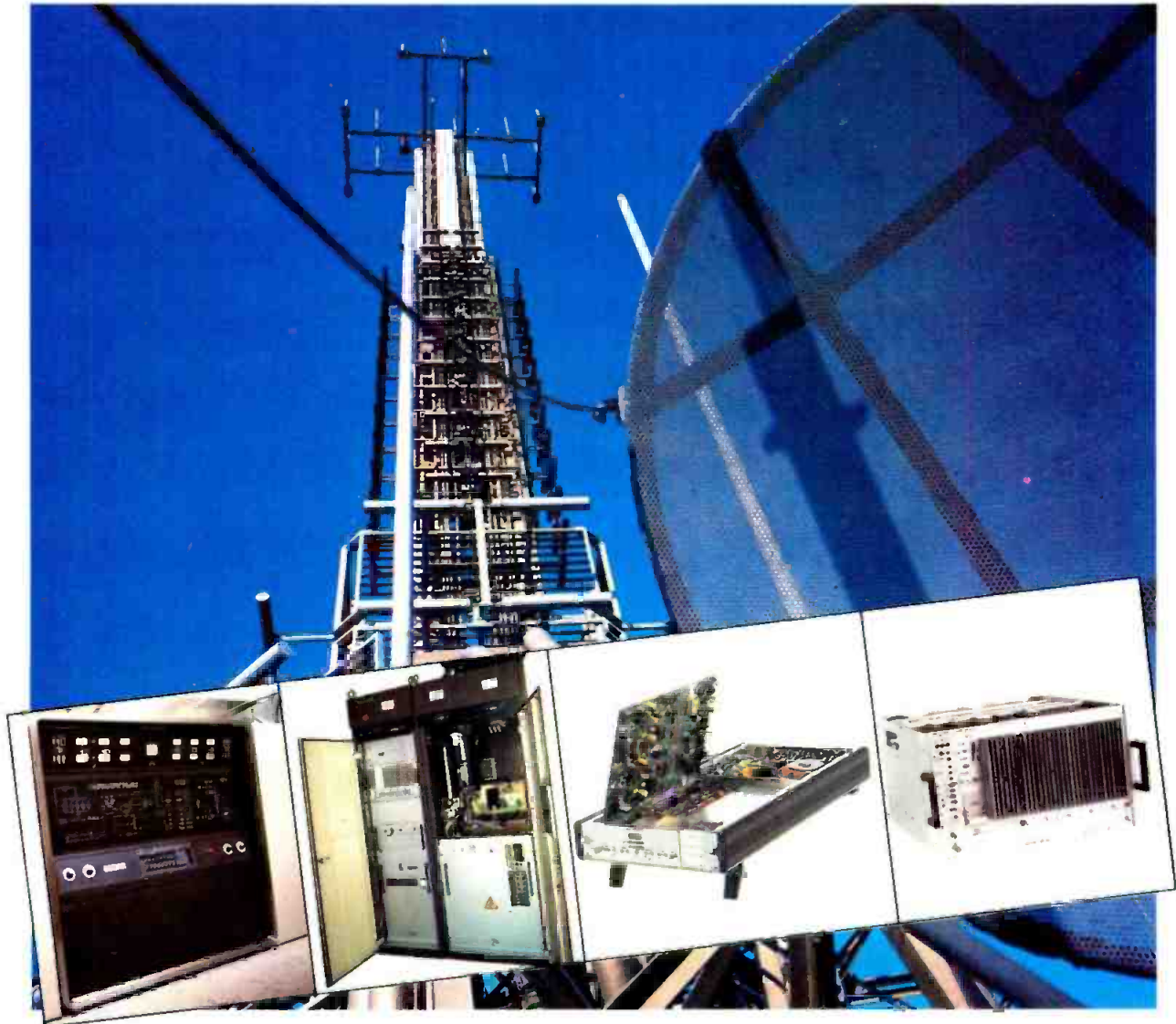

At the forefront of state-of-the-art techniques, THOMSON-CSF encompasses all activities associated with radio and television broadcasting for transmission and reception.

In the field of radiobroadcasting, THOMSON-CSF's Broadcasting and Television Division is present all over the world with more than 2500 systems

installed. The transmitters cover the whole power range from 20 kW to 1000 kW for amplitude modulation, and from 50W to 10 kW for frequency modulation.

In the field of television transmitters, D.R.T. and the Laboratoire Général des Télécommunications - a THOMSON-CSF's subsidiary -

are leaders in the world market with more than 1200 transmitters and repeaters from 1 W to 50 kW (SECAM, PAL and NTSC standards).

THOMSON-CSF also produces the necessary radio and television antennas, designs and implements nationwide coverage network using the most appropriate systems.

A COMPLETE RANGE BASED ON 30 YEARS OF EXPERIENCE.



THOMSON-CSF
COMMUNICATIONS

DIVISION
RADIODIFFUSION-TÉLÉVISION
94, rue du Fossé Blanc
92231 Gennevilliers/France
Tél. : (1) 790.65.49

LABORATOIRE GÉNÉRAL
DES TÉLÉCOMMUNICATIONS
51, Bd de la République
78400 Chatou/France
Tél. : (3) 071.92.61

BAZAINE 5098

Manufacturers

Mic mixers, portable & TV audio consoles; 2-, 4-track & multitrack ATRs, time delay decks; parametric & graphic equalizers; analog special effects, reverb; noise reduction; monitor speakers.

FOTO-KEM INDUSTRIES
2800 W. Olive Ave., Burbank, CA 91505
213 846-3101

✓ **MEANS IT'S
VERIFIED**

Film-to-tape transfers; videotape duplications.

FREELAND PRODUCTS CO. ✓
Rt. 7 Box 628, Covington, LA 70433
504 893-1243
RF power tubes.

FREQUENCY DEVICES, INC. ✓
25 Locust St., Haverhill, MA 08130
617 374-0761
Equalizers & filters, audio noise reduction systems; amp power supplies; audio tone test signal generators.

FREZZOLINI ELECTRONICS, INC. ✓

7 Valley St., Hawthorne, NJ 07506
201 427-1160
Lamps, quartz lighting fixtures, lighting stands & rigging, diffusion & efx material; nicad batteries & chargers, inverters & converters. Equipment rental service; engineering consultant.
[See ad on pg. 186](#)
Refer to Reps/Distributors section

FUJINON, INC. ✓

672 White Plains Rd., Scarsdale, NY 10583
914 472-9800
Camera lenses, extenders.
[See ad on pg. 51](#)
Field Offices:
CA Keith Tindall, 118 Savarona Way,
Carson 90746 213 532-2861
John Geiger, 4855 Atherton Ave.,
San Jose 95130 408 866-5466
TX David Waddell, 2101 Midway, Suite
350, Carrollton 75006 . . 214 385-8902

FUJI PHOTO FILM USA, INC. ✓

350 Fifth Ave., New York, NY 10118
212 736-3335
Audio cassettes; two-inch, one-inch, ¾-inch U-Matic & half-inch Beta videocassettes; video head cleaners.
[See ad on pg. 113](#)
Field Offices:
CA 1211 E. Artesia Blvd., Carson
90746 213 636-0101
GA 5461 Peachtree Industrial Blvd.,
Norcross 30092 404 441-2222
IL 1000 Pratt Blvd., Elk Grove Village
60007 312 569-3500
TX 3500 Garden Brook Dr., Dallas
75234 214 243-2537

GABRIEL ELECTRONICS, INC.

Box 610, Scarborough, ME 04074
207 883-5161
Receive only satellite earth stations; microwave, waveguide STLs; microwave & satellite dish antennas; solid core & foam dielectric transmission line.

GAGNON LAFOREST, INC. ✓

930 Wellington, Montreal H3C 1V1, Canada
514 861-6768
Scenery rigging.

GARDINER COMMUNICATIONS CORP. ✓

3605 Security St., Garland, TX 75042
214 348-4747
Receive only satellite earth stations; LNAs, receivers, switchers.

GARNER INDUSTRIES ✓

4200 N. 48 St., Lincoln, NE 68504
402 464-5911
Audio tape duplicators; bulk erasers for audio & videotape.

GBH PRODUCTION SERVICES ✓

125 Western Ave., Boston, MA 02134
617 492-2777
Studio & mobile teleproduction facilities; video post-production facility.

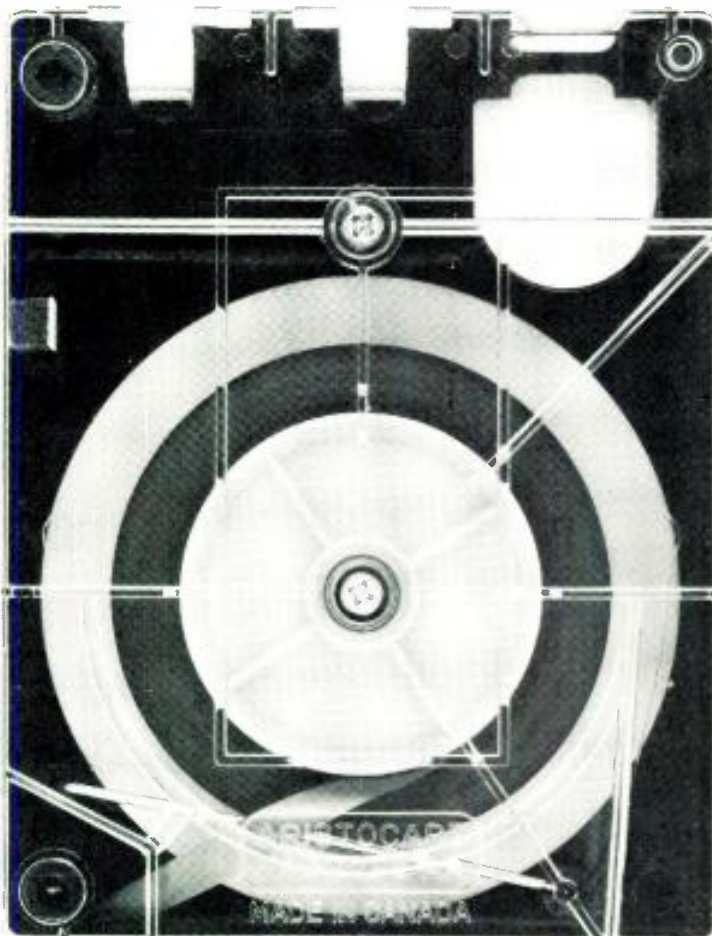

ARISTOCART

no other NAB cartridge meets these exacting standards

We designed the ARISTOCART cartridge 10 years ago. Its features have been widely copied but it continues to outperform competing products because we alone take the trouble to check each unit we ship for phase stability and frequency response in conformity with NAB specifications.

our guarantee

If any ARISTOCART cartridge should fail to meet NAB AM/FM performance specifications on a properly aligned cart machine, we will replace it at our sole expense.



MANUFACTURED BY ARISTOCART DIV., WESTERN INTERNATIONAL COMMUNICATIONS LTD.
505 BURNARD STREET, VANCOUVER, B.C., CANADA V7X 1M6 TEL: (604) 687-2844 TELEX: 04-54639

Circle 162 on Reader Service Card

GENERAL ELECTRIC CO. LIGHTING BUSINESS GROUP ✓
Nela Park, Cleveland, OH 44112
216 266-2092
Incandescent & quartz stage/studio lamps.

GENERAL ELECTRIC CO., PROJECTION DISPLAY OPERATION ✓
Electronics Park 6-206, Syracuse, NY 13221
315 456-2152
Video projectors.

GENERAL TELEVISION NETWORK ✓
13225 Capital Ave., Oak Park, MI 48237
313 548-2500

Equipment rental service; audio & video post-production facilities; recording studio; stage, studio rentals; facility turnkey installations; engineering consultant; studio, set design; earth station site selection; mobile vehicle construction.

GENERIC COMPUTER SYSTEMS
Box 151, Butler, PA 16001
412 283-1500
Radio business automation hardware; facility turnkey installations; financial services; automatic traffic/billing.

GERSTENSLAGER CO. ✓
1425 E. Bowman St., Wooster, OH 44691
216 262-2015
Mobile vehicle construction.

GF BUSINESS EQUIP./EMCOR PRODS. ✓
1600 Fourth Ave. NW, Rochester, MN 55901
507 289-3371
Studio consoles, 19-inch equipment racks.

GKM MFG. CORP. ✓
57 Bridgewater St., Brooklyn, NY 11222
212 388-4114
19-inch equipment racks.

GLETRONIX (1977), LTD. ✓
160 Duncan Mill Rd., Don Mills, Ont. M3B 1Z5, Canada
416 444-8497
Rental services; exclusive Canadian distributor of. Ross video switchers and special effects systems; Dynatech jackfields; Telcom Research time code generators, readers & synchronizers; Porta-Pattern test charts; CMC Technology head rebuilding program; Scientel sideband analyzers; Torpey clocks & timing systems.

GLOBAL ASSOCIATES ✓
Box 12156, Oakland, CA 94604
415 834-8242
Remote facilities support services.

GLOBAL SPECIALTHES CORP. ✓
70 Fulton Terrace, New Haven, CT 06509
203 624-3103
RF frequency counter; audio function generator, scope multiplexers.

GLOBAL VIDEO COMMUNICATIONS ✓
744 W. Church St., Orlando, FL 32805
305 843-8982

Duplicating services & international TV standards conversion.

G&M POWER PRODUCTS
6362 Santa Monica Blvd., Los Angeles, CA 90038
213 465-8236
Nicad & lead-acid batteries, chargers; ac power dividers; inverters, converters; monitoring devices, analyzers, condition monitors.

GOLDEN WEST VIDEOTAPE
5800 Sunset Blvd., Box 500, Los Angeles,

CA 90028
213 460-5866
Studio & mobile teleproduction facilities; video post-production facility

ALAN GORDON ENTERPRISES, INC. ✓
1430 N. Cahuenga Blvd., Hollywood, CA 90028
213 466-3561
Manufacturer and distributor of cine production equipment: tripods; Swintek RF mics; director's viewfinder; NCE animation motors; film projectors; portable lighting; Elemack

STROBEGUARD®

HIGH INTENSITY
OBSTRUCTION
LIGHTING SYSTEMS*
FOR TELEVISION AND
RADIO TOWERS AND
SIMILAR SKELETAL
STRUCTURES.



TECHNICAL PRODUCTS GROUP — BEDFORD DIVISION
35 CONGRESS ST., SALEM, MASSACHUSETTS 01970
TEL: (617) 745-3200
ATTENTION: GEORGE MANDEVILLE, PRODUCT MANAGER

* FAA APPROVED as meeting or exceeding the requirements of Advisory Circular AC 150/5345-43 and FAA/DoD Specifications L-856 plus FAA AC 70/74601

FACT!

No one can match The Complete Lightning Protection Systems from LEA.

- ANTENNA DISSIPATION ARRAYS FOR AM, FM, TV, MICROWAVE TOWERS
- SURGE ELIMINATORS FOR MAIN POWER LINES TO HANDLE ENERGY LEVELS OF 50,000 JOULES PER PHASE
- COAXIAL TRANSMISSION LINE SURGE ELIMINATORS 1Kw to 25 Kw
- KLEANLINE ELECTRONIC FILTERING SYSTEMS TO PROTECT AGAINST LIGHTNING STRIKES AT 50,000 JOULES PER PHASE PLUS AN RF/EMI FILTER TO HANDLE RF INTERFERENCE FOR SENSITIVE SOLID STATE EQUIPMENT.
- TRANSIENT ELIMINATORS FOR DATA LINES, PHONE LINES, COMMUNICATIONS EQUIPMENT WITH A FREQUENCY RESPONSE FROM D.C. TO 1 GIGAHERTZ.
- LIGHTNING WARNING SYSTEMS PROVIDING 1/2 HOUR ADVANCE WARNING OF AN APPROACHING STORM.
- SURGE AND TRANSIENT GENERATORS
- GROUND SYSTEMS
- CONSULTING SERVICES
- PERFECT POWER SOURCE VOLTAGE REGULATION
- CONTINUOUS POWER SOURCE

**LEA, Inc.,
a Dynatech Company**

(formerly Lightning Elimination Associates)
12516 Lakeland Road
Santa Fe Springs, CA 90670
(213) 944-0916
TWX: 910-586-1381



Perfect Power Source
Circle 164 on Reader Service Card

Manufacturers

dollies, Supergrip camera support equipment.

GORMAN-REDLICH MFG. CO. ✓
6 Curtis St., Athens, OH 45701
614 593-3150

EBS two-tone systems; weather radios; antenna monitors; phase meters; FM receiving antennas.

GOTHAM AUDIO CORP. ✓
741 Washington St., New York, NY 10014
212 741-7411

Importer of portable consoles, mono, stereo & TV audio consoles; portable ATRs; 2,4-track & multitrack studio ATRs; turntables, pickup arms, phono cartridges, complete disc consoles; AM & FM compressor/limiters, digital delay & reverb, analog special effects & reverb, mechanical reverb, audio noise reduction; monitor speakers; electret/condenser & shotgun mics & mic supports; PPM & LED audio level indicators, video monitor display meters; wow & flutter meters.

GRAHAM-PATTEN SYSTEMS, INC. ✓
Box 1960, Grass Valley, CA 95945
916 273-8412

Audio DAs. Title keyers, downstream keyers; post-production audio mixers; video signal, cable equalizers; video pulse amps, DAs, SC amps. Facility turnkey installations.

THE GRAPHIC EXPRESS CORP. ✓
3678 Fourth St., San Diego, CA 92103
619 298-2834

Lighting design; studio, set design; news-graphic slide service.

GRASIS CORP. ✓
Box 1039, Kansas City, MO 64141
816 483-1100

Towers, masts, tower lighting; electronic equipment shelters.

THE GRASS VALLEY GROUP, INC. ✓
Box 1114, Grass Valley, CA 95945
916 273-8421

Large studio, compact studio/mobile & automated production switchers, post-production switchers; digital video effects processors, RGB & encoded chromakeyers, title keyers, downstream keyers; manual & automated master control switchers; parallel & serial interface machine control systems; sync, black burst generators; video proc amps, pulse amps, DAs, SC amps; sc/h phase monitor; fiber optic STLs.

GRAY COMMUNICATIONS CONSULTANTS ✓
5441 Pepsi St., New Orleans, LA 70123
504 733-7265
800 252-9577
Builds production vans.

GRAY ENGINEERING LABS, INC. ✓

504 W. Chapman Ave., Ste. P., Orange, CA 92668
714 997-4151
SMPTE time code generators, readers; safe

title area generators; VITC encoders & decoders; video assisted film editing equipment. See ad on pg. 154

Refer to Reps/Distributors section

THE GREAT AMERICAN MARKET ✓

Box 178, Woodland Hills, CA 91364
213 883-8182

Lamps, HMI & quartz fixtures, lighting control boards, cyc lighting, lighting projection & special effects.

DAVID GREEN BROADCAST CONSULTANTS CORP. ✓

Box 590, Leesburg, VA 22075
703 777-8660

Production equipment rentals & sales.

GREGG LABORATORIES ✓

1542-A Moulton Pky., Tustin, CA 92680
714 730-1100

Mono & stereo studio audio consoles; phono preamps; ALC & AGC amps, AM & FM compressor/limiters, TV audio processor; telco interface equipment.

GRINNAN FIXTURE CO. ✓

16041 Georgetown St. NE, Minerva, OH 44657

216 862-2323

Facility turnkey installations, engineering consultation, mobile vehicle construction, studio cabinets & furniture.

GROSH SCENIC STUDIOS ✓

4114 Sunset Blvd., Hollywood, CA 90029
213 662-1134

Lighting stands, grip; modular news & studio sets, scenery construction & rigging.

GROTON COMPUTER, INC.

19 Fort Hill Rd., Groton, CT 06340
203 445-2325

Complete program automation systems, radio business automation hardware.

GROVE VIDEO

16851 Oakmont Ave., Gaithersburg, MD 20877

301 840-5801

Video animation controllers; character generators, character generator/framestores, digital graphics systems, camera/VTR digitizers; digital video effects processors.

GRUBER PRODUCTS CO.

Box 7350, Toledo, OH 43615
419 531-4900

Mobile ENG carts, projection tables.

GRUMMAN AEROSPACE CORP. ✓

Sunrise Hwy., Great River, NY 11739
516 435-6001

Sync processors; time code generators & readers; VITS remote control monitors; custom routing switchers; digital video frame syncs, color identification; RF test equipment; antenna tuning units; 19-inch equipment racks; facility turnkey installation; mobile vehicle construction.

GRUVER RECORDING & SERVICE CO.

Box 16, Perkasio, PA 18944
215 257-4460

Manufacturers

Audio cassettes; audio post-production facility & recording studio; music library, syndicated radio programming & tower maintenance.

GTE LENKURT, INC. ✓
1105 Country Rd., San Carlos, CA 94070
415 595-3000

Intercity microwave equipment; RF program subcarrier; comm. & monitor receivers; microwave & telco STLs; transmit/receive, receive only satellite earth stations; fiberoptic video transmission systems; CATV transmission equipment.

GTE/SYLVANIA LIGHTING PRODUCTS ✓

Sylvania Lighting Center, Danvers, MA 01923
617 777-1900
Quartz lamps.

HALLIKAINEN & FRIENDS, INC. ✓

101 Suburban Rd., San Luis Obispo, CA 93401
805 541-0200

TV audio consoles; remote control systems. Log printers; automatic transmitter logging & control.

HARDIGG INDUSTRIES, INC. ✓

N. Main St., S. Deerfield, MA 01373

413 665-2163
Foam insert & rack configuration transportation cases.

HARRIS CORP. BROADCAST GROUP ✓

Box 4290, Quincy, IL 62305
217 222-8200

Mic mixers; portable, stereo & mono studio & automated audio consoles; electronic audio editors; time insertion sequencers, complete program automation systems, auto time/weather announcers, radio business automation hardware & newsroom computers & word processing. ALC & AGC amps, AM & FM compressor/limiters. Studio, ENG/EFP & lightweight video cameras, solid state cameras; digital still stores; TBCs, frame synchronizers, framestores, TBC/framestores. Camera tripods, heads, pedestals, ENG braces, remote pan/tilt systems, helicopter rigs. AM, FM, UHF & VHF transmitters; AM, AM stereo, FM & TV exciters, stereo generators, modulators; transmit/receive, receive only & transportable satellite earth stations; intercity, portable ENG & airborne microwave, central receivers; remote control systems; remote pickup equipment; microwave & satellite STLs; FM & TV SCA equipment; AM, FM & TV (HP & CP) TV antennas; microwave, satellite dish & communications antennas, antenna tuning units; RF phasing network. Modulation monitors. Studio consoles. Engineering consultant; earth station site selection; mobile vehicle construction.

See ad on pg. 175

Field Offices:

CA 333 N. Lantana St. Ste. 122,
Camarillo 93010

(Radio) 805 987-7111

(TV) 805 987-7107

DC 2600 Virginia Ave., NW Suite 800,
Washington 20037 202 342-3900

NO OTHER BATTERIES EVEN COME CLOSE!

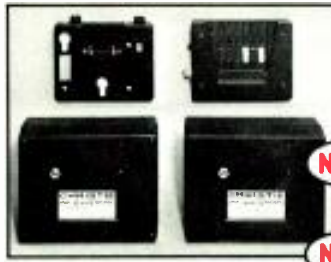

ReFLEX®-20—the only battery charging system that gives a full charge in 20 minutes with longer battery life and requiring fewer batteries to buy—now brings you four more reasons to use Christie camera-mounted, belt-mounted, and VCR batteries.

NEW

Batteries Fit Most Mounts

Christie "burping" KS and KR batteries now fit virtually all factory camera battery mounts.

NEW

Slow-Charger and 20-Minute Charger

Every Christie battery can now be fully charged in 20 minutes on the patented ReFLEX-20 "burping" charger (now available from under \$1,000), or when on the road with our inexpensive, compact, slow-charger. Receive our slow-charger **FREE** with the purchase of a ReFLEX charger or by meeting minimum battery order requirements.

NEW

Unique Pre-Charge Warning Light

You won't be caught with a dead Christie battery because our new *discharge indicator light* warns you before it's time to recharge. Our batteries now give you *overtemperature protection* without the need for thermal fuses. No flimsy shrink tubing on our BP90 equivalent batteries—you get a *rugged hard case*.

NEW

12-Month Warranty

Incredible but true. Under normal use, Christie will repair or replace a defective battery free of charge for a full year. (Complete warranty available on request.)

LIMITED WARRANTY (ABSTRACT)

REFLEX-20 BATTERIES

Any battery pack which becomes defective, or has permanently lost more than 1/3 of its rated capacity, under proper (normal) use within one (1) year of delivery to the user, Christie will repair or replace at no charge.

For Christie battery details, contact Steve Heller at Christie Electric Corp., 20665 Manhattan Place, Torrance, California 90501, **800-421-2955** (in California 213-320-0808), TWX 910-349-6260.

Since 1929 **CHRISTIE**
You Can Depend On Us

Circle 165 on Reader Service Card

AM BROADCASTING - HIGH FIDELITY Are these terms mutually exclusive?

YES NO DON'T KNOW

Surprisingly, many broadcasters may not know that the correct answer to this question is no. Large sums of money are spent each year to purchase new transmitters, new studio equipment, new audio processing equipment and to modify antenna systems for improved AM sound. Unfortunately, until now, there has been no such thing as a professional quality AM monitor receiver. As a result, the perceived fidelity of an AM signal has been severely restricted by receiver performance.

Potomac has developed the SMR-11 Synthesized Monitor Receiver which will let you hear and measure the quality of your transmitted AM signal ... perhaps for the first time. Features include: Crystal Stability; 60 dB Signal to Noise Ratio; Audio Frequency Response ± 0.5 dB, 20 Hz to 8 kHz; Total Harmonic Distortion less than 0.2% (95% Modulation) at audio frequencies above 40 Hz ... please write for complete descriptive brochure.



THIS DIAL WILL TUNE YOU IN TO THE
NEW SOUND OF AM BROADCASTING

POTOMAC INSTRUMENTS

932 PHILADELPHIA AVE.
SILVER SPRING, MD. 20910
(301) 589-2662

Circle 166 on Reader Service Card

Manufacturers

HARRIS CORP., BROADCAST MICROWAVE ✓

1680 Bayport Ave., San Carlos, CA 94070
415 595-3500
Intercity, portable ENG & airborne microwave, central receivers; microwave STLs.

HARRIS CORP., SATELLITE COMM. DIV. ✓

Box 1700, Melbourne, FL 32901
305 724-3000
Transmit/receive & receive only satellite earth stations.

HARRIS CORP., SATELLITE COMM. DIV., ANTENNA OP. ✓

Box 1277, Kilgore, TX 75662
214 984-0555
Transmit/receive, receive only & transportable satellite earth stations; satellite dish antennas; facility turnkey installations.

HARRIS VIDEO SYSTEMS ✓

1255 E. Arques Ave., Sunnyvale, CA 94086
408 737-2100
Digital still stores; video editor/controllers; TBCs, frame synchronizers, TBC/frame-stores.

HARRISON SYSTEMS, INC. ✓

Box 22964, Nashville, TN 37202
615 834-1184
Studio and remote manual or automated stereo audio consoles for TV or radio production, post-production, or on-air; edit suite, film dubbing, music recording, and scoring mixers; live sound reinforcement; console automation; automated graphic equalizers; VU & PPM audio level indicators; video graphic audio level displays.

HAWAII PRODUCTION CENTER ✓

1534 Kapiolani Blvd., Honolulu, HI 96814
808 944-5200
Studio & mobile teleproduction facilities; video post-production facility.

H.B.O. STUDIOS ✓

120-A E. 23 St., New York, NY 10010
212 477-8600
Teleproduction & post-production facilities.

HEATH CO. ✓

Benton Harbor, MI 49022
616 982-3200
Audio preamps, monitor & power amps; LED audio level indicators; frequency monitors, harmonic distortion meters, oscilloscopes, vectorscopes, voltmeters, dB meters; computer systems including digital weather systems; video projectors.

HEDCO (HUGHES ELECTRONIC DEVICES CORP.) ✓

Box 1985, Grass Valley, CA 95945
916 273-9524
Audio line amps, DAs; audio routing switchers. Parallel & serial interface video routing switchers; video signal, cable equalizers; video pulse amps, DAs & SC amps; return loss bridges; terminations.

KARL HEITZ, INC. ✓

34-11 62 St., Box 427, Woodside, NY 11377
212 565-0004

Tripods, heads, dollies; lighting stands & rigging.

HEWLETT-PACKARD CO. ✓

1501 Page Mill Rd., Palo Alto, CA 94304
415 857-1501
Automated test & measuring systems; differential phase/gain measurement; frequency monitors & counters; audio & RF generators; impedance bridges; logic analyzers, modulation monitors, oscilloscopes, phase meters, sideband analyzers, spectrum analyzers, voltmeters, multimeters, dB meters; TV & computer equipment; audio preamps & line amps.

HF SIGNALLING, INC. ✓

3101 Mercier, Box 17510, Kansas City, MO 64130
816 931-4448
Audio test signal generators, harmonic distortion meters; voltmeters.

HICKOK ELECTRICAL INSTRUMENTS CO. ✓

10514 DuPont Ave., Cleveland, OH 44108
216 541-8060
Video test signal generators; oscilloscopes, multimeters, logic analyzers.

HIPOTRONICS ✓

P.O. Drawer A, Route 22, Brewster, NY 10509
914 279-8091
Automatic voltage regulators & ac/dc high voltage test sets.
[See ad on pg. 107](#)

Refer to Reps/Distributors section

HITACHI DENSHI AMERICA, LTD. ✓

175 Crossways Park W., Woodbury, NY 11797
516 921-7200
Studio, field, ENG/EFP, lightweight, single-tube, single-piece, b&w & solid state cameras; one-inch C VTRs, pro VHS VCRs; VTR slow-mo controller; telecine cameras; TBCs; monochrome & RGB monitors.
[See ad on pg. 47](#)

HM ELECTRONICS, INC. ✓

6151 Fairmount Ave., San Diego, CA 92120
619 280-6050
RF & hardwired intercoms; RF mics; two-way radio communications transmitters, receivers; RF measurement links.

HORIZONTAL EDITING STUDIOS ✓

2625 W. Olive Ave., Burbank, CA 91505
213 841-6750
Video post-production facility.

HOWE AUDIO PRODUCTIONS ✓

3085-A Bluff St., Boulder, CO 80301
800 525-7520
Mic mixers; stereo, radio & TV audio consoles; stereo tape phase corrector; telco interface equipment.

HSC, INC. ✓

2211 Oakton St., Unit 10, Arlington Heights, IL 60005
312 956-7580
Studio furniture, studio consoles, 19-inch equipment racks; custom rack-mounting hardware for video equipment. Engineering consultant; mobile vehicle construction.

HUGHES HELICOPTERS, INC. ✓

5320 Arizona Circle, Los Angeles, CA 90045
213 305-5000
Broadcast-equipped helicopters.

HUGHES MICROWAVE COMM. PRODUCTS ✓

Box 2999, Torrance, CA 90509
213 517-6233
Receive only satellite earth stations; intercity microwave; microwave STLs; satellite dish antennas.

HUGHEY & PHILLIPS, INC. ✓

Box 6729, Burbank, CA 91510
213 849-1104
Tower lighting; transformers; lightning rods; isolation transformers.

IDEAL INDUSTRIES, INC. ✓

Becker Pl., Sycamore, IL 60178
815 895-5181
Dimmer packs; lighting, ac cable; connectors, tools.

IGM COMMUNICATIONS ✓

4041 Home Rd., Bellingham, WA 98226
206 733-4567
Complete automation systems; custom computer/microprocessor automation controllers; audio cart player/recorders.

IKEGAMI ELECTRONICS (U.S.A.), INC. ✓

37 Brook Ave., Maywood, NJ 07607
201 368-9171
Studio, field, ENG/EFP, HDTV, EC, single piece & monochrome cameras; CCUs, lenses, pickup tubes, camera accessories; telecine cameras; monochrome, NTSC & RGB video monitors.
[See ad on pg. 69](#)

Field Offices: ✓

CA 3445 Kashiwa St.,
Torrance 90505 213 534-0050
FL 6201 Johns Rd., Ste. 5,
Tampa 33614 813 884-2046
IN 31-08 Red Maple Ct.,
South Bend 46628 219 277-8240
MO 12623 Woody Grove Dr.,
St. Louis 63141 314 878-6290
TX 330 N. Belt E., Ste. 228,
Houston 77060 713 445-0100

IMAGE DEVICES INTERNATIONAL ✓

1825 NE 149 St., Miami, FL 33181
305 945-1111
Video & cine, lighting & grip equipment rentals; camera cranes & generators; underwater cameras & lights; portable audio mixer; cassette player/recorders; electret/condenser mics.

IMAGE MAGNIFICATION, INC. ✓

739 Airway Circle, New Smyrna Beach, FL 32069



MOTOROLA AM STEREO



With monophonic distortion less than 0.25% at 85% modulation and stereophonic exciter to monitor typical separation of 35 dB, the Motorola C-QUAM[®] AM Stereo system is an impressive performer. The MC-13020 IC, with comparable levels of technical performance, is the perfect complement for decoding Motorola AM Stereo at the receiver. Broadcast exciters and monitors, receiver decoder ICs and receivers modified for AM Stereo are all available from Motorola. For price and specifications, call Dick Harasek at (312) 576-2879 or Chris Payne at (202) 862-1549.

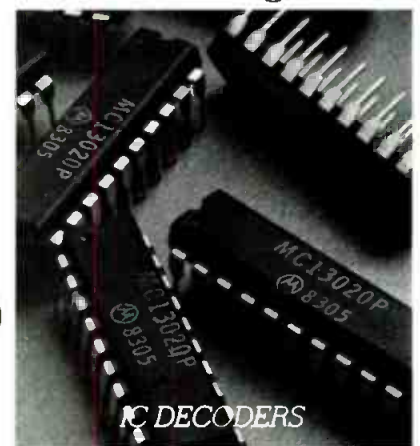

MOTOROLA AM STEREO. THE WINNING SYSTEM.



Circle 167 on Reader Service Card

www.americanradiohistory.com

Manufacturers

904 427-5294

Video projectors.

IMAGE RESOURCE CORP. ✓
2260 Townsgate Rd., Westlake Village, CA 91361

805 496-3317
Color film recorder.

IMAGE RESOURCES, INC. ✓
801 S. Orlando Ave., Winter Park, FL 32789
305 645-4200
Studio & mobile teleproduction facilities; video post-production facility.

IMAGE TRANSFORM, INC. ✓
4142 Lankershim Blvd., N. Hollywood, CA 91602
213 985-7566
Video post-production facility; film laboratory; tape-to-film transfers & standards conversions.



IMAGE VIDEO ✓
705 Progress Ave., Unit 46, Scarborough, Ont. M1H 2X1, Canada
416 438-3940

Manual, automated & business automation interfaced master control switchers; parallel & serial interface routing switchers; parallel & serial interface machine control; video DAs.

INDUSTRIAL ACOUSTICS ✓
1160 Commerce Ave., Bronx, NY 10462
212 931-8000

Noise suppression and control for broadcast structures; audiometric testing & air conditioning silencers.

INDUSTRIAL RESEARCH PRODUCTS, INC. ✓
321 N. Bond St., Elk Grove Village, IL 60004
312 439-3600

Digital audio special effects; audio/video sync delay; automatic mic mixers.

INDUSTRIAL SCIENCES, INC. (ISI) ✓
3521 SW 42 Ave., Box 1495, Gainesville, FL 32608
800 874-7590

Portable, large studio, compact studio/mobile & automated video production switchers; post-production switchers; stand-alone effects generators; RGB & encoded chromakeyers, downstream keyers; manual & automated master control switchers; parallel & serial interface routing switchers; sync, black burst & color bar generators; video proc amps, pulse amps, DAs, SC amps; mono audio mixing consoles.

INFORMATION PROCESSING SYSTEMS OF CALIFORNIA, INC. ✓
70 Glenn Way, Ste. 2, Belmont, CA 94002
415 592-1742
TV weather satellite recorders; color graphics system.

INFORMATION TRANSMISSION SYSTEMS CORP. (ITS) ✓
16 E. Water St., Canonsburg, PA 15317
412 745-0500
UHF exciter/modulators.

INMARK CORP. ✓
147 W. Cedar St., Norwalk, CT 06854
203 866-8474
High vacuum capacitors.

INNOVATIVE TELEVISION EQUIPMENT (ITE) ✓
Box 681, Woodland Hills, CA 91365
213 888-9421
Camera heads, tripods, dollies, ENG braces, pedestals; microwave support & portable equipment.

INOVONICS, INC. ✓
503B Vandell Way, Campbell, CA 95008
408 374-8300
Audio & magnetic film recorder replacement electronics; ATR tape tension servo kit; ALC & AGC amps, AM & FM compressor/limiters; noise reduction systems; PPM meters; spectrum analyzers.
[See ad on pg. 168](#)

INTEGRATED SOUND SYSTEMS ✓
29-50 Northern Blvd., Long Island City, NY 11101
212 729-8400
Time compression/expansion; graphic equalizers; stereo audio consoles; turntables & complete disc consoles; monitor speakers; dynamic, electret/condenser & shotgun mics; monitor & power amps.

INTERACTIVE SYSTEMS CO. ✓
5601 N. Broadway, Boulder, CO 80302
303 447-2013
Videotape editing systems; SMPTE & proprietary time code generators, readers & synchronizers.

INTERAND CORP. ✓
666 N. Lake Shore Dr., Suite 1100, Chicago, IL 60611
312 943-1200
Video animation controller; digital art/paint systems, bit pad digitizers, weather symbol inserter, "draw-on-screen" systems; digital effects processors, standalone effects generators, colorizers.

INTERFACE DATA SYSTEMS, INC. ✓
2990 E. La Jolla St., Anaheim, CA 92806
714 630-8030
Complete program automation systems, time insertion sequencers, computer automation controllers, radio business automation hardware, radio newsroom computers.

INTERFACE ELECTRONICS ✓
6710 Alder, Houston, TX 77081
713 660-0100
Portable audio consoles.

INTERFACE VIDEO SYSTEMS, INC. ✓
1333 New Hampshire Ave. NW, Washington, DC 20036
202 861-0500

Teleproduction & post-production facilities.

INTERNATIONAL ELECTRO-MAGNETICS ✓
350 N. Eric Dr., Palatine, IL 60067
312 358-4622
Replacement & rebuilt audio & video heads; graphic equalizers.

INTERNATIONAL INSTRUMENTS, DIV. SIGMA ✓
88 Marsh Hill Rd., Orange, CT 06477
203 795-4711
Voltmeters, dB meters.

INTERNATIONAL MICROWAVE CORP. ✓
33 River Rd., Cos Cob, CT 06807
203 661-6277
Intercity, portable & ENG microwave equipment; RF program subcarrier, RF amps; microwave STLs; AM & FM transmitters.

INTERNATIONAL NUCLEAR CORP. ✓
608 Norris Ave., Nashville, TN 37204
615 254-3365

Audio preamps, line, monitor & power amps, amp power supplies; audio DAs; EBS two-tone systems. Portable, large studio, compact studio/mobile & automated production switchers; post-production switchers; stand-alone video effects generators, colorizers, RGB & encoded chromakeyers, downstream keyers; manual & automated master control switchers; parallel & serial interface routing switchers; black burst generators; video signal, cable equalizers; video proc amps, pulse amps, DAs, SC amps.

INTERNATIONAL PRODUCTION CENTER ✓
514 W. 57 St., New York, NY 10019
800 223-0622
Teleproduction facility; video post-production facility. Videotape duplication.

INTERNATIONAL TAPETRONICS CORP. (ITC)/3M ✓
2425 S. Main St., Bloomington, IL 61701
309 828-1381
Single-deck, triple-deck & time delay audio cart player/recorders; 2,4-track studio ATRs; audio carts.
[See ad on pgs. 72, 73](#)
Refer to Reps/Distributors section

INTERNATIONAL VIDEO CORP. ✓
455 W. Maude Ave., Sunnyvale, CA 94086
408 738-3900
On- & off-line video editors; station automation system; frame store synchronizer; editing VTR.

ITI ELECTRONICS, INC. ✓
369 Lexington Ave., Clifton, NJ 07011
201 546-3900
Audio preamps, line, monitor & power amps, amp power supplies.

ITT JENNINGS ✓
970 McLaughlin Ave., San Jose, CA 95122
408 292-4025
RF switches; voltmeters.



For 10 seasons now, you've taken the performance of Shure's remote mixers for granted. We haven't. Announcing the new Shure M267.

Over a decade ago, Shure introduced the M67 Microphone Mixer. Designed to provide on-location audio for major sporting and news events, the M67 became the most well known and widely used remote mixer in the broadcast industry.

Then came the new Shure M267. One look will tell you why we moved ahead.

Here are all the improvements audio engineers have asked for.

Every channel on the mixer now has a mic/line level switch for maximum flexibility. There's also a built-in limiter to keep the M267 from overloading at critical moments. The unit contains a built-in battery pack that utilizes three standard 9-volt batteries. Simplex (phantom)

power and a peak LED are standard, too.

The M267 oscillator provides a clean 1 kHz tone, and is located on the front of the unit for simple access. The headphone output is also on the front and includes a level control.

And IC design, along with active gain controls, provides greater headroom and quieter operation.

For location work or even studio post-production, the M267 carries on Shure's reputation for reliability and ruggedness.

After all, just because you create one legend doesn't mean you can't build another.

For more information on the complete line of mixers, call or write Shure Brothers Inc., 222 Hartrey Ave., Evanston, IL 60204, (312) 866-2553.

SHURE®

THE SOUND OF THE PROFESSIONALS... WORLDWIDE

Circle 168 on Reader Service Card

Manufacturers

IVIE ELECTRONICS ✓
1366 West Center, Orem, UT 84057
801 224-1800
Graphic equalizers, digital audio delay & reverb; audio preamps, monitor & power amps; audio test signal generators, spectrum analyzers.

JAM CREATIVE PRODUCTIONS, INC.
4631 Insurance Ln., Dallas, TX 75205
214 526-7080
Recording studio; music library; station ID jingle packages.

JAMIESON & ASSOC., INC. ✓
5200 Wilson Rd., Minneapolis, MN 55427
612 920-3770
Radio & TV station design; facility turnkey installations; engineering consultant; studio, set design.

THE JANSON INDUSTRIES ✓
1200 Garfield Ave. SW, Canton, OH 44706
216 455-7029
Scenery construction; scenery & rigging, props & materials; cycloramas.

JATEX, INC. ✓
2626 Freewood Dr., Dallas, TX 75220
214 358-0200
Video & audio editing systems; SMPTE and proprietary time code generators & readers.

JAVELIN ELECTRONICS, INC. ✓
19831 Magellan Dr., Torrance, CA 90502
213 327-7440
Solid state monochrome and color video cameras; camera lenses & extenders; monochrome & color picture monitors; video DAs; remote pan & tilt systems; time lapse video action recorders; video source ID systems; modulators.

JEFFERSON DATA SYSTEMS ✓
Executive Plaza, 501 Archdale Dr., Charlotte, NC 28210
704 525-3901
Business data systems for radio & TV; newsroom computers.

JEFFERSON PRODUCTIONS
1 Julian Price Pl., Charlotte, NC 28208
704 374-3823
Studio & mobile teleproduction facilities; video post-production facility.

JENEL CONSULTANTS CORP.
9550 Forest Ln., Ste. 400, Dallas, TX 75243
214 343-1229
Complete radio program automation systems. Jackfields, patch panels; hum bucking coils. Facility turnkey installations; engineering consultant; mobile vehicle construction.

JENSEN TOOLS, INC. ✓
7815 S. 46 St., Phoenix, AZ 85040
602 968-6241
Tools.

JENSEN TRANSFORMERS
10735 Burbank Blvd., N. Hollywood, CA 91601
213 876-0059
Transformers.

E.M. JOHNSON & ASSOC., INC.
1 Regency Sq., Ste. 450, Knoxville, TN 37915
615 521-6464
Engineering consultant.

JOHNSON ELECTRONICS, INC. ✓
62 S. Highways 17-92, Casselberry, FL 32707
305 339-2111
EBS two-tone systems. FM & TV SCA receiving equipment; FM antennas. SCA dual subchannel manual & remote switching.
[See ad on pg. 164](#)

JONES TELEVISION PRODUCTIONS, INC.
517 Chester St., Little Rock, AR 72201
501 372-4285
Studio & mobile teleproduction facilities; video post-production facility.

JRF CO., INC. ✓
101 Landing Rd., Landing, NJ 07850
201 398-7426
Replacement & rebuilt audio heads & assemblies.

J.S.L. VIDEO SERVICES, INC.
25 W. 45 St., New York, NY 10036
212 575-5802
Video post-production facility.

JVC CO. OF AMERICA ✓
41 Slater Dr., Elmwood Park, NJ 07407
201 794-3900
ENG/EFP, lightweight & single-tube video cameras; camera lenses & extenders; U-type & pro VHS VCRs; compact production switchers; editor/controllers; SMPTE time code generators & readers; NTSC, RGB & dc portable video monitors. Nicad batteries & chargers.
[See ad on pg. 87](#)
Field Offices:
CA Logan Enright, 1011 W. Artesia Blvd., Compton 90220 213 537-6020
IL Douglas DiGiacomo, 2250 Lively Blvd., Elk Grove Village 60007 312 364-9300
TX Charles Roberts, 407 Garden Oaks Blvd., Houston 77018 . . 713 694-0666

JV ELECTRONICS ✓
17 Logstone Crescent, West Hill, Ont. M1E 4M2 Canada
416 214-0900
Audio DAs.

KAHN COMMUNICATIONS, INC. ✓
839 Stewart Ave., Garden City, NY 11530
516 222-2221
Audio line amps; AM stereo exciters; low frequency extenders; AM compressor/limiters; stereo generators.

KAITRONICS CORP. ✓
1540 Gilbreth Rd., Burlingame, CA 94010
415 697-9102
Studio & portable production switchers; parallel & serial interface routing switchers; parallel interface machine control; SMPTE time code generators & readers; color bar generators; satellite switchers, cable & teleconferencing switchers.

KALAMUSIC ✓
151 S. Rose St., Ste. 600, Kalamazoo, MI 49007
616 385-5110
Syndicated radio programming; music library.

KALART VICTOR CORP. ✓
Hultenius St., Plainville, CT 06062
203 747-1663
Editing, splicing, rewinding equipment; 16 mm telecine projectors, optical multiplexers.

KAMAN SCIENCES/KAMAN BROADCASTING SYS. ✓
Box 7463, 1500 Garden of the Gods Rd., Colorado Springs, CO 80933
303 599-1601
Radio & TV newsroom computers; business & program automation equipment.

KANGAROO VIDEO PRODUCTS ✓
9190 Manor Dr., La Mesa, CA 92041
619 698-0230
Nylon VCR, camera & equipment carrying cases.

KANSAS PUBLIC TELECOMMUNICATIONS, INC.
320 W. 21 St., Wichita, KS 67203
316 838-3090
Audio & video post-production facilities; recording studio; video/film production.

KAPPA NETWORKS, INC.
165 Roosevelt Ave., Carteret, NJ 07008
201 541-1600
Phasing networks; delay lines; RF inductors & transformers; engineering consultation.

KARTES VIDEO COMMUNICATIONS, INC. ✓
10 E. 106 St., Indianapolis, IN 46280
317 844-7403
Studio & mobile teleproduction facilities; video post-production facility.

KAVCO, INC. ✓
3931 Image Dr., Dayton, OH 45414
513 898-2003
Parallel & serial interface machine control systems; mobile vehicle construction; facility turnkey installations & engineering consultation.

KAVOURAS, INC. ✓
6301 34 Ave. S., Minneapolis, MN 55450
612 726-9515
Weather radar satellite systems & data display; weather & production graphics generating equipment.
[See ad on pg. 35](#)

KAY ELEMETRICS CORP. ✓
12 Maple Ave., Pine Brook, NJ 07058
201 227-2000
RF test signal generators; spectrum analyzers.

KB SYSTEMS ✓
10407 62 Pl. W., Everett, WA 98204
206 355-8740
Film editing equipment; sprocketed film transports; digital clocks & timers.

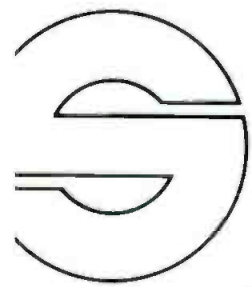

Sachtler

Panorama

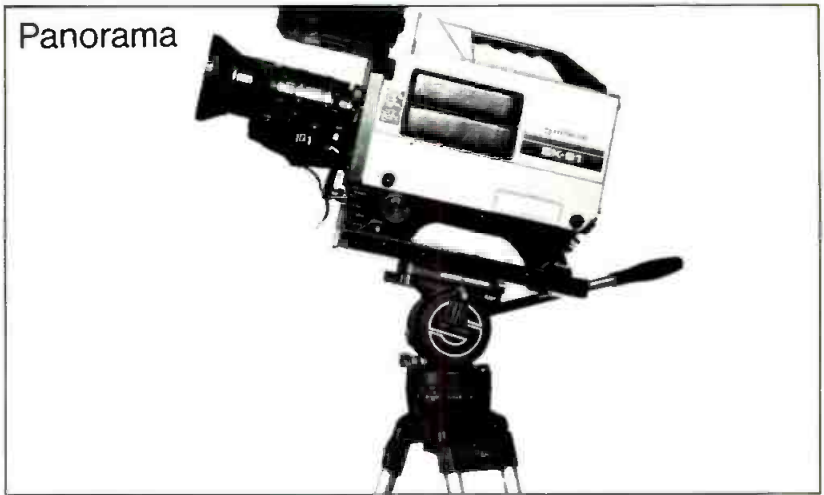

THE PERFECT HEADLINE

for your ENG- or EFP-camera

Sachtler
camera supporting systems
engineering

all-in-one – up to seven – steps of drag,
independently adjustable for pan and tilt,

tilt in compensation for center of
gravity displacements,

camera-adequate or dynamic counter-
balancing, adjustable on the spot
to fulfill all your possible requirements,

extreme positive, operational locks,
without effecting camera orientation
when operated,

leak-proof by design fluid system
with guaranteed (for years) trouble free
operation,

all-in-one piece unit for easy handling
and transport,

it is available when and where you need it
worldwide.

the Sachtler headline offering all
these features, don't ask for less!

Call on your nearest Sachtler dealer

or write to

Sachtler Corporation of America
10 Oser Avenue, Hauppauge NY 11788
Phone (516) 231 0033, Telex 140170,

subsidiary of Sachtler GmbH
Postfach 16
8046 Garching/München
Phone (89) 320 40 41, Telex 5215 340

Video 20

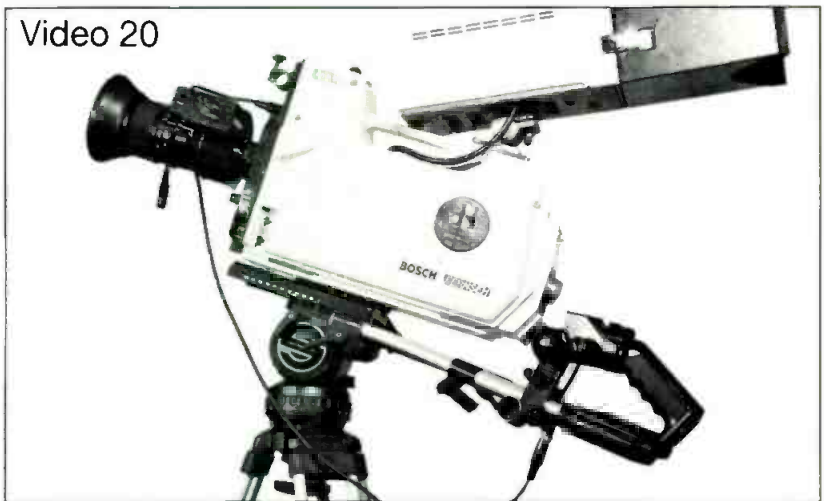

Video 25

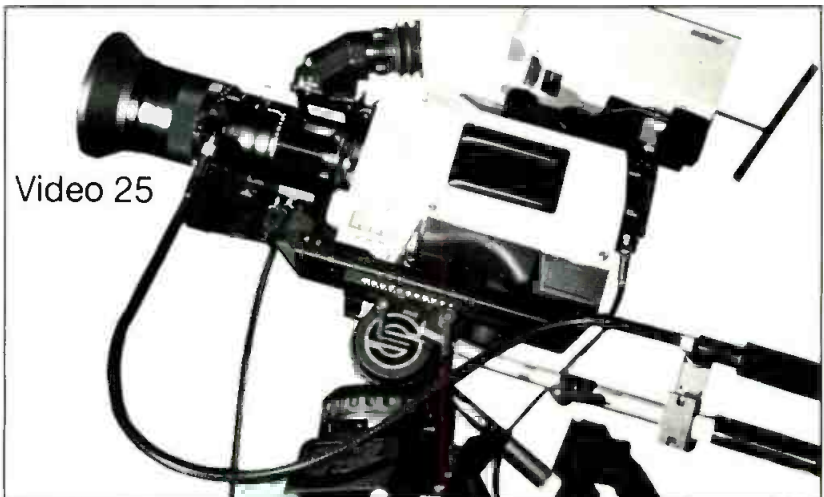

Video 30



A CHOICE TO MEET YOUR NEEDS



MRC-2

Moseley's finest, the state-of-the-art MRC-2, offers Microprocessor Remote Control of up to 99 sites, with as many as 225 control lines, 255 status and 255 telemetry channels per site. Multiple Control Terminals and multiple data links give flexible control. Telemetry inputs can be calibrated in one of six modes and there are dual upper and lower, user-defined telemetry limits. Each status channel can alarm on rising, falling, or rising and falling waveforms. Optional multiple CRTs and Loggers add even greater flexibility. The Automatic Control Unit option adds both time and feedback-oriented command abilities to the system for truly automated plant control.

- USER DEFINED SOFTWARE
- CLEAR ENGLISH DISPLAY
- MULTI-REMOTE AND MULTI-COMMAND SITE CAPABILITY
- MULTIPLE TRANSMISSION CHANNELS

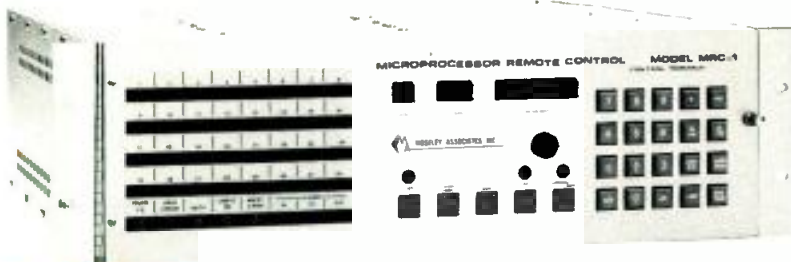

MRC-1

The MRC-1 is the leading Microprocessor Remote Control for broadcasters today. System setup tailors, exactly to your needs, up to 64 command outputs and 32 status and telemetry inputs for up to nine sites. There are upper and lower telemetry limits available, automatic telemetry muting and four ways to keyboard-calibrate telemetry channels. The optional Moseley Memory protects setup data for up to 10 years, while CRT and logger options simplify operator control. The Multiple Direct Command option offers instant access to the 10 most critical parameters at one or more sites.

- UP TO 64 COMMAND LINES PER SITE
- MULTIPLE REMOTE SITE CAPABILITY
- AUTOMATIC TELEMTRY MUTING
- USER DEFINED SYSTEM SETUP

For further information please contact our Marketing Department.

MOSELEY ASSOCIATES, INC.

A Flow General Company . Santa Barbara Research Park

111 Castilian Drive . Goleta, California 93117
(805) 968-9621 . Telex: 658-448 . Cable: MOSELEY

Circle 170 on Reader Service Card

Manufacturers

K&H PRODUCTS, LTD.
See Porta-Brace

KILOVAC CORP., DOW-KEY DIV. ✓
Box 4422, Santa Barbara, CA 93103
805 684-4560
RF switches.

KING INSTRUMENT CORP. ✓
80 Turnpike Rd., Westboro, MA 01581
617 366-9141
Audio & video cassette loaders; videotape evaluators.

KINGS ELECTRONICS
40 Marbledale Rd., Tuckahoe, NY 10707
914 793-5000
Patch panels, coaxial & triaxial connectors.

KITCHEN PRODUCTIONS
619 W. Ridgecrest Blvd., Ridgecrest, CA 93555
714 375-2753
LPTV switching equipment; turnkey installations, engineering consultation & earth station site selection.

KLARK-TEKNIK ELECTRONICS, INC. ✓
262A Eastern Pkwy., Farmingdale, NY 11735
516 249-3660
Graphic equalizers; digital & analog audio special effects, mechanical reverb; spectrum analyzers.

KLIEGL BROS. ✓
32-32 48 Ave., Long Island City, NY 11101
212 786-7474
Lighting control boards; quartz fixtures, lighting stands; cyc lighting.

KLINE IRON & STEEL CO., INC. ✓
Box 1013, Columbia, SC 29202
803 779-7080
Tower masts, hardware & construction equipment.

KNOX VIDEO PRODUCTS, DIV. GROVE CORP. ✓
8547 Grovemont Cir., Gaithersburg, MD 20877
301 840-5805
Character generators, colorizers; video proc amps & DAs.

KOSS CORP. ✓
4129 N. Port Washington St., Milwaukee, WI 53212
414 964-5000
Dynamic & electrostatic headphones, speakers; digital delay systems; cassette players; audio/video cleaning products.

KOZIN INTERNATIONAL
836 Greenwood Ct., Carpentersville, IL 60110
312 428-2495
Audio cassettes, carts, reels; leader tape.

KQED PRODUCTIONS ✓
500 8 St., San Francisco, CA 94103
415 553-2137
Studio & mobile teleproduction facilities; video post-production facility.

KTVY

Box 14068, Oklahoma City, OK 73113
405 478-1212
Studio & mobile teleproduction facilities; video post-production facility.

KVIE VIDEO

Box 6, Sacramento, CA 95801
916 929-5797
Studio & mobile teleproduction facilities; video post-production facility; equipment rental; teleconferencing.

LAIRD TELEMEDIA

2424 S. 2570 West, Salt Lake City, UT 84119
801 972-5900
16/35 mm telecine projectors, 35 mm slide projectors; optical multiplexers; character generators.

LAKE SYSTEMS CORP.

55 Chapel St., Newton, MA 02160
617 244-6881
Video cart automation system.
See ad on pg. 131



LANDY ASSOCIATES, INC.

1890 E. Marlton Pike, Cherry Hill, NJ 08003
609 424-4660
Equipment sales & rental service; facility turnkey installations; engineering consultant; service & repair; mobile van construction.
See ad on pg. 152

Field Office:

MA Landy Associates, Inc., 801 Water St., Framingham, 01701... 617 877-9570

LANG VIDEO SYSTEMS CORP.

700 Warrington Ave., Redwood City, CA 94063
415 364-1287
Video SID systems; video DAs; ENG switchers.

JAMES B. LANSING SOUND, INC. (JBL)

8500 Balboa Blvd., Northridge, CA 91329
213 893-8411
Audio line, monitor & power amps; monitor speakers; electronic crossover units.

LARCAN COMMUNICATIONS EQUIPMENT, INC.

6520 Northam Dr., Mississauga, Ont. L4V 1H9 Canada
416 678-9970
FM, UHF & VHF transmitters, translators; RF amplifiers, FM & TV exciters, diplexers; TV HP antennas; facility turnkey installations.

LAUDERDALE ELECTRONIC LABS

16 SW 13 St., Ft. Lauderdale, FL 33315
305 764-7755
Audio alignment, tension gauges; bulk audio & video erasers, tape cleaners & evaluators; splicing blocks & tape; record cleaning, care; mic stands, booms & dollies; audio

ECONOMY AND RELIABILITY



- 16 CHANNELS EACH, STATUS AND TELEMTRY
- 16 RAISE AND 16 LOWER COMMAND LINES
- SETUP DATA BACKED UP AUTOMATICALLY

MRC-1600

Already the top-selling Micro-processor Remote Control, the MRC-1600 offers flexibility and reliability in a highly economical package. The MRC-1600 provides 16 status channels, 16 telemetry channels, and 16 raise/lower relay-isolated command channels. In case of a temporary power-down of either terminal, all setup data is stored at both Control and Remote Terminals to avoid memory loss. Plug-in modules allow the MRC 1600 to be used with almost any interconnection network, including 2- or 4-wire telephone line, subaudible, FM subcarrier, or a combination of these.

Status inputs may be set to alarm on rising, falling, rising and falling waveforms, or muted completely. Each telemetry channel can be calibrated in one of four modes: power, indirect power, linear, or millivolt. Upper and lower telemetry limits may be set or disabled independently. In operation, telemetry data is checked against these limits. Exceeding these limits enables visible and audible alarms. Data needed to bring telemetry back within limits is automatically displayed when an operator acknowledges an alarm.

The MRC-1600 has full control fail-safe features and maintains special channels to monitor data link conditions and A/D ratios. A maintenance override mode continues to update status and telemetry data while locking out command signals from the Control Terminal.

- ADAPTS TO ANY INTER-CONNECTION NETWORK
- ALL TELEMTRY LIMITS MAY BE SET OR DISABLED INDEPENDENTLY

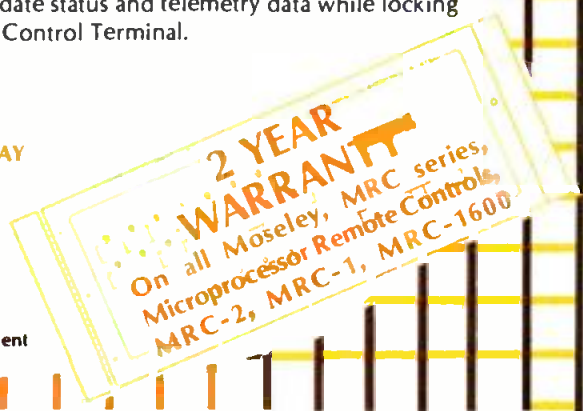

For further information, please contact our Marketing Department



MOSELEY ASSOCIATES, INC.

A Flow General Company . Santa Barbara Research Park

111 Castilian Drive . . . Goleta, California 93117
(805) 968-9621 . Telex: 658-448 . Cable: MOSELEY

Circle 171 on Reader Service Card

Manufacturers

preamps, DAs; video head cleaners, degaussers. Digital clicks, timers.

LAUMIC CO. ✓

306 E. 39 St., New York, NY 10016
212 889-3300

Distribution and rental of video editing systems & other film & video equipment.

See ad on pg. 152

LEA, INC., A DYNATECH CO. ✓

12516 Lakeland Rd., Santa Fe Springs, CA 90670

213 944-0916

Lightning eliminators, surge protectors.

See ad on pg. 94

Refer to Reps/Distributors section

LEADER BROADCAST SYSTEMS, INC. ✓

835 W. 7 Ave., Vancouver, BC V5Z 1C2
Canada

604 873-4771

Distribution & rental of full line of audio and video equipment, including portable, 2-, 4-track, multitrack & time delay ATRs; audio cassette player/recorders; Solor sprocketed magnetic film transports; replacement & rebuilt heads, head degaussers, alignment & tension gauges; Elector SMPTE time code synchronizers, VU & PPM meters; Milab dynamic, electret/condenser mics, mic stands, booms & dollies. Distributor of full line of other audio equipment.

LEADER INSTRUMENTS CORP. ✓

380 Oser Ave., Hauppauge, NY 11788
516 231-6900

DC power supplies; TV field intensity meters, RF power meters & wattmeters, RF test signal generators, impedance bridges, frequency counters; harmonic distortion meters, wow & flutter meters; video test signal generators, waveform monitors, vectorscopes; oscilloscopes, delayed sweep scopes, voltmeters, multimeters, dB meters.

See ad on pg. 149

LEAR SIEGLER, INC., BOGEN DIV. ✓

Box 500, Paramus, NJ 07652
201 343-5700

Audio preamps, line, monitor & power amps; compressor/limiters; graphic equalizers; hardwired intercoms.

LEASAMETRIC, INC. ✓

1164 Triton Dr., Foster City, CA 94404
800 447-4700

Test equipment rentals.

See ad on pg. 174

LEBLANC & ROYLE COMMUNICATIONS, INC. ✓

514 Chartwell Rd., Box 880, Oakville, Ont. L6J 5C5, Canada

416 844-1242

AM antennas; towers & masts, tower hardware & construction equipment, tower lighting.

LECTROTECH, INC. ✓

5810 N. Western Ave., Chicago, IL 60659
312 769-6262

Color picture monitors; oscilloscopes,

vectorscopes, frequency monitors & counters.

LEE LIGHTING AMERICA, LTD. ✓

534 W. 25 St., New York, NY 10001
212 691-1910

Camera cranes & dollies; lamps, CSI & quartz fixtures; lighting stands & rigging; lighting control boards, dimmer packs, diffusion & efx material, cyc lighting; generators; power dividers, inverters & converters.

LEE-RAY INDUSTRIES, INC. ✓

38 E. 1 Ave., Mesa, AZ 85202
602 962-6806

Video equipment carriers.

LEITCH VIDEO, LTD. ✓

10 Dyas Rd., Don Mills, Ont. M3B 1V5,
Canada

416 445-9640

Video sync, black burst, color bar, multiburst, staircase ramp, source ID & safe title area generators; video delay lines, video signal & cable equalizers; video proc amps, pulse amps, DAs & SC amps; monitor calibrators. Video test signal generators; sc/h phase monitor; digital clocks, master & slave clocks.

LEMO USA, INC. ✓

Box 11006, Santa Rosa, CA 95406
707 578-8811

Audio patch panels; connectors, jackfields.

LENCO INC., ELECTRONICS DIV. ✓

300 N. Maryland St., Jackson, MO 63755
314 243-3147

Video sync, black burst, color bar, multiburst & staircase ramp generators; NTSC encoders, decoders; video delay lines; video proc amps, pulse amps, DAs, SC amps; monochrome, NTSC & RGB video monitors. RF demodulators; video noise meters.

LENZAR OPTICS CORP. ✓

1006 W. 15 St., Riviera Beach, FL 33403
305 844-0263

Camera lenses.

LERRO ELECTRICAL CORP., COMM. SYSTEMS DIV. ✓

3125 N. Broad St., Philadelphia, PA 19132
215 223-8200

Mobile van design & construction; facility turnkey installations.

LEXICON, INC. ✓

60 Turner St., Waltham, MA 02154
617 891-6790

Digital audio special effects, digital delay & reverb, audio/video sync delay, audio time compression/expansion.

LIBRA PROGRAMMING, INC. ✓

1945 E. 7000 South, Salt Lake City, UT 84121

800 453-3827

Radio business & traffic automation hardware.

LIGHTNING ELIMINATION ASSOC. ✓

See LEA



LINE ONE VIDEO ✓

220 E. 23 St., New York, NY 10010
212 696-5440

Teleproduction & video post-production facilities.

LINES VIDEO SYSTEMS ✓

219 S. Jefferson, Springfield, MO 65806
800 641-4674/417 862-5533

LPTV & TV installations; ENG vans.

LIPSNER-SMITH CO., SUBSIDIARY RTI ✓

4700 Chase Ave., Lincolnwood, IL 60646
312 675-8473/800 323-7520

Audio power rewind; ultrasonic film cleaners; editing, production consoles.

LISTEC TELEVISION EQUIPMENT CORP. ✓

39 Cain Dr., Plainview, NY 11803
516 694-8963

Vinten tripods, heads, pedestals, crane arms, remote digital camera control system; Listec monitor-based teleprompters, computer & portable prompters.

See ad on pg. 184

Refer to Reps/Distributors section

LIVE SOUND, INC. ✓

1741 N. Ivar St., Ste. 118, Hollywood, CA 90028

213 462-3351

Music library; syndicated radio programming.

LNR COMMUNICATIONS ✓

180 Marcus Blvd., Hauppauge, NY 11787
516 273-7111

Satellite earth stations, transmitters; LNRs & frequency converters.

LODES/PETERSON PRODUCTIONS ✓

10125 J St., Omaha, NE 68127
402 592-7230

Studio & mobile teleproduction facilities; video past-production facility.

LOGETRONICS/DUNN INSTRUMENTS ✓

544 2 St., San Francisco, CA 94107
415 957-1600

Color film recorder for computer graphic applications.

See ad on pg. 157

Refer to Reps/Distributors section

LOGICA, INC. ✓

666 Third Ave., New York, NY 10017
212 599-0828

Digital art/paint systems; teletext editing & transmission systems.

LOGITEK ✓

3320 Bering Dr., Houston, TX 77057
800 231-5870/713 782-4592 (TX, AK, HI)

Portable, mono & stereo studio, automated & audio for TV mixing consoles; phono preamps; audio preamps, line, monitor & power amps, DAs; LED audio level indicators; tim-

THE BROADEST LINE OF TELEPRODUCTION GRAPHIC TITLERS IN THE WORLD

QUANTAFONT® 98

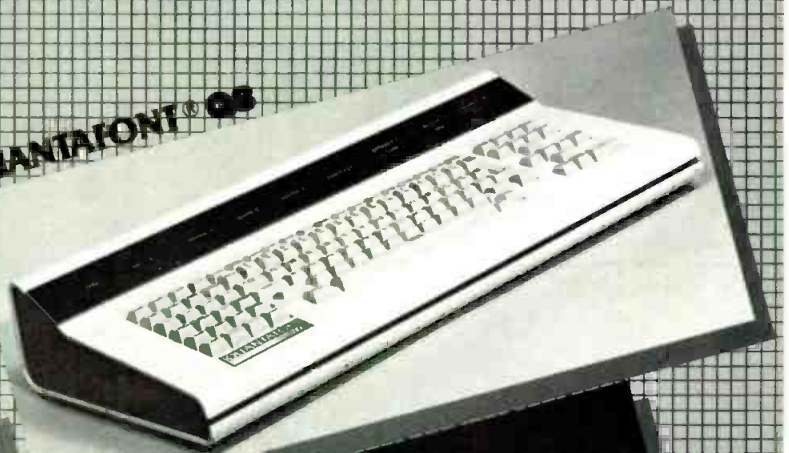

QUANTAFONT SELECT 7



MICROGEN™



**Choose Your Solution from the Shapes
and Strengths of Quanta Technology.**

QUANTA™

2440 So. Progress Drive, Salt Lake City, Utah 84119
(801) 974-0992 TWX 910-925-5684

Sales Offices: California, San Jose (408) 985-8888
Connecticut, Danbury (203) 797-1179
Georgia, Atlanta (404) 493-3913
Ohio, Cleveland (216) 692-3410
Oklahoma, Tulsa (918) 627-4151
The Netherlands, Aalsmeer
(31) 2977-23473
TLX 18241 QUANT NL

Registered trademark of Quanta Corporation

Circle 175 on Reader Service Card

www.americanradiohistory.com

Manufacturers

ers; AGC amps, voltage-controlled amps; speakers. Turnkey radio studios. Quiz program equipment & scoreboards.

LONG ENGINEERING CO.

961 Burke St., Winston-Salem, NC 27101
919 725-2306

Radio & TV studio design; facility turnkey installations; Deltronix custom mixers & consoles, intercom systems & transformers.

LORAL MICROWAVE COMMUNICATIONS

9020 Balboa Ave., San Diego, CA 92123
714 278-4100

FM transmitters; intercity, portable ENG & airborne microwave; central microwave receivers; microwave & telco STLs; microwave antennas.

LOUISVILLE PRODUCTIONS

520 W. Chestnut St., Louisville, KY 40202
502 582-7744

Studio & mobile teleproduction facilities; video post-production facility.

LOWEL-LIGHT MFG., INC.

475 10 Ave., New York, NY 10018
212 947-0950

Professional lightweight location lighting equipment & kits.

See ad on pg. 148

Field Office:

CA Roy Lowe, Lowell West, 3407 W. Olive Ave., Burbank 91505... 213 846-7740

LPB, INC.

28 Bacton Hill Rd., Frazer, PA 19355
215 644-1123

Mic mixers; mono, stereo & audio for TV mixing consoles; turntables, pickup arms; AM & FM compressor/limiters; audio DAs. AM transmitters; highway & travelers information broadcast systems.

See ad on pg. 84

Field Office:

CA Richard Burden, 20944 Sherman Way, Canoga Park 91303... 213 340-4590

LRP

311 E. 47 St., New York, NY 10017
212 759-0822

Video post-production facility; studio and mobile teleproduction facilities; film-to-tape transfer.

LTM CORP. OF AMERICA

1160 N. Las Palmas Ave., Hollywood CA
90038

213 460-6166
Lamps; HMI, CSI & quartz fixtures; lighting stands & rigging; lighting control boards; cyc lighting. Nicad, silver-zinc & lead-acid batteries & chargers; inverters, converters; foam insert transportation cases. Lighting & ac cable, connectors. Mic mixers; mic stands, booms & dollies. Equipment rental service; stage, studio rentals; studio, set design.

L-W INTERNATIONAL

6416 Variel Ave., Woodland Hills, CA 91367
213 348-8614

16/35 mm telecine projectors.

LYON LAMB VIDEO ANIMATION

8257 Beverly Blvd., Los Angeles, CA 90048
213 655-0606

Video animation controllers; single-frame video editors; camera/VTR digitizers.

LYREC

Box 95, U.S. Rt. 7, Brookfield, CT 06804
203 775-4465

2-, 4-, & multitrack ATRs; 1/4- & 1/2-inch master recorders; studio 1- & 2-inch cassette duplication systems; playback editor.

3M CO., MAGNETIC AUDIO/VIDEO PRODUCTS DIV.

3M Center, St. Paul, MN 55144
612 733-1110

Open-reel audio tape, carts & cassettes; sprocketed magnetic film; empty reels & carts, leader tape, tape loaders. Two-inch, one-inch, 3/4-inch & half-inch videotape; tape cleaners & evaluators, empty reels & containers; fixed head, open-reel digital audio recorders.

See ad on pgs. 56, 57

Refer to 3M Broadcast Related Products Div. for Field Offices



Merlin ME 238-80 Kit extends Ampex VPR-80 to 3 hour recording/playback time.

Record, play and dub complete sporting events and full-length movies . . . non-stop.

Extended play time allows most full-length movies and sporting events to be recorded on a single reel. Ideal for master playback when dubbing to small format machines as well as cable and broadcast automated programming.

Merlin ME 238 conversions for Ampex VPR-2 and Marconi recorders are available in both portable and console versions, extending Ampex play time to 2 hours, 40 minutes; Marconi machines to 3 hours.

Also available for Sony BVU Series VTRs.



MERLIN

1880 Embarcadero, Palo Alto, CA 94303

Call Toll Free — 800-227-1980 (California — Call Collect 415-856-0900)

Merlin Engineering has a full range of products and assemblies for bringing your broadcast VTR up to date, as well as complete engineering facilities for custom applications. Write for your copy of the Merlin catalog.



Circle 173 on Reader Service Card

3M CO., BROADCAST & RELATED PRODUCTS DIV. ✓

3M Center, St. Paul, MN 55144
612 733-1110

One-inch C VTRs; VTR slow-mo controllers; character generators, camera/VTR digitizers; colorizers; parallel & serial interface routing switchers; serial interface machine control; sync, black burst & color bar generators; video proc amps, DAs.
See ad on pgs. 9, 171

Field Offices:

AK 5331 Minnesota Dr., Anchorage
99502 907 276-2363

CA 6023 South Garfield Ave.,
Los Angeles 90040 213 726-6338

CA 320 Shaw Rd.,
So. San Francisco
94080 415 761-1155

DC 1101 15th St. N.W., Ste. 1100,
Washington 20005 202 331-6930

GA 2860 Bankers Industrial Dr.,
Atlanta 30360 404 447-7088

HI Box 30048,
Honolulu 96820 808 422-2721

IL 6850 S. Harlem Ave.,
Bedford Park, Argo
60501 312 496-6619

MA 155 Fourth Ave.,
Needham Heights
02194 617 449-0300

MI 23923 Research Dr.,
Farmington 48024 313 477-5000

MN Box 33211,
St. Paul 55133 612 733-3300

MO Box 510,
St. Louis 63166 314 997-8522

NC Box 2047,
High Point 27261 919 889-7181

NJ Box 2076,
W. Caldwell 07006 201 575-2007

OH 4835 Para Dr.,
Cincinnati 45237 513 482-3128

OH 12200 Brookpark Rd.,
Cleveland 44130 216 362-3217

PA 5698 Rising Sun Ave.,
Philadelphia 19120 215 728-5325

TX Box 28158,
Dallas 75228 214 324-8171

WA 100 Andover Park West,
Andover Industrial Park,
Seattle 98188 206 241-2270

MackENZIE LABORATORIES

5507 N. Peck Rd., Arcadia, CA 91006
213 579-0440

Single-deck, dual/triple-deck & multideck
cart player/recorders.

M/A-COM DCC, INC. ✓

11717 Exploration Ln., Germantown, MD
20874

301 428-5500

Transmit/receive, receive only, transportable,
& digital satellite earth stations; digital
signal processing; radio program distribution.

M/A-COM MVS, INC. ✓

63 Third Ave., Burlington, MA 01803
617 272-3000

Receive only satellite earth stations; intercity,
portable ENG & airborne microwave; micro-
wave central receivers & relay systems; re-
mote control systems; remote pickup

equipment; microwave & fiberoptic STLs;
satellite dish antennas; fiberoptic broadcast
transmission system.

MAGNASYNC/MOVIOLA CORP. ✓

5539 Riverton Ave., N. Hollywood, CA 91603
213 763-8441

16/35 mm telecine systems; sprocketed

magnetic film transports; film/video synchro-
nizers.

MAGNA-TECH ELECTRONIC CO., INC. ✓

630 Ninth Ave., New York, NY 10036
212 586-7240

Sprocketed magnetic film transports, dub-
bers; film/video synchronizers.

MAGNAVOX ✓

Box 6950, Knoxville, TN 37914
615-521-4316

PMX AM stereo system.

✓ MEANS IT'S
VERIFIED

Leading transmitter manufacturers are switching to automatic voltage regulators made by Hipotronics*

They are switching for improved:

- EFFICIENCY
 - RELIABILITY
 - CUSTOM DESIGN
 - DELIVERY AND SERVICE
- plus:
- SIZE REDUCTION
 - WEIGHT REDUCTION
 - COST REDUCTION

To learn more call our sales
department at (914) 279-8091

*HIPOTRONICS' REGULATORS INCORPORATE THE PATENTED PESCHEL VARIABLE TRANSFORMER™



REGULATOR SHOWN WITH
COVER PANELS REMOVED.

Hipotronics

P.O. Drawer A, Route 22, Brewster, New York 10509
Phone (914) 279-8091
Tlx 710-574-2420 HIPO BRWS NY. Tlx: 178915-HIPBNY

Circle #174 Send Literature Only
Circle #175 Have Salesman Call

BM/E AUGUST, 1983 107

Manufacturers

MAGNECRAFT ELECTRIC CO. ✓
5575 N. Lynch Ave., Chicago, IL 60630
312 282-5500
Coaxial & RF switches/relays.

MAGNETIC REFERENCE LAB
229 Polaris Ave., Ste. 4, Mountain View, CA 94043
415 965-8187
Audio test tapes.

MAGNICOM SYSTEMS ✓
1177 High Ridge Rd., Stamford, CT 06905
800 243-5300
Radio, TV & cable TV business computer systems.

MAGNUM TOWERS, INC. ✓
9370 Eider Creek Rd., Sacramento, CA 95826
916 381-5053
Towers & masts, tower hardware & construction equipment.

THE MANAGEMENT ✓
Box T, Aledo, TX 76008
817 441-8045
Radio business computer systems.

MARATHON PRODUCTS CORP. ✓
334 W. Boylston St., W. Boylston, MA 01583
617 853-0988
Audio head degaussers; carts & test tapes, tape cleaners & evaluators, torque testers, speed indicators; tape cart reloading; splicing blocks, tape.

MARCOM
Box 66507, Scotts Valley, CA 95066
408 438-4273
Rood extended bandwidth telephone transmission system; distributor of full line audio, video, RF & T&M equipment; facility turnkey installations; engineering consultant.

MARCONI ELECTRONICS, INC. ✓
100 Stonehurst Ct., Northvale, NJ 07647
201 767-7250

Studio video cameras; one-inch C VTRs; solid state telecines, telecine color correctors; colorizers; sync, black burst & color bar generators; NTSC encoders, decoders, video signal & cable equalizers; TBCs, color correctors; video pulse amps & DAs; video test charts & slides; video monitoring unit. AM, FM, UHF & VHF transmitters; two-way radio communications transmitters, receivers. Studio consoles, 19-inch equipment racks; jackfields, patch panels.

MARCONI INSTRUMENTS, INC. ✓
100 Stonehurst Ct., Northvale, NJ 07647
201 767-6666
Television blanking interval timer; insertion signal analyzer.

MARKETRON
2180 Sand Hill Rd., Menlo Park, CA 94025
415 854-5301
Business computer services for radio & TV; automated playlist program system.

MARSHALL CLAUDE MICHAEL
9674 Telstar Ave., El Monte, CA 91731
213 686-0141

Oscilloscopes, voltmeters, multimeters, logic analyzers; tool kits.

MARSHALL ELECTRONIC
1205 York Rd., Ste. 14, Lutherville, MD 21093
301 484-2220
Digital audio special effects, delay & reverb; analog special effects, audio/video sync delay, time compression/expansion.



MARTI ELECTRONICS, INC. ✓
Box 661, Cleburne, TX 76031
817 645-9163
Audio ALC/AGC amps, compressor limiters; dynamic mics; line, monitor & power amps. Portable & airborne microwave; remote control systems & remote pickup. Microwave STLs; FM & TV SCA equipment. Two-way radio transmitters, receivers; transmission line & program subcarrier.
[See ad on pg. 52](#)

MASTER BROADCAST SERVICES, INC.
6 E. Trenton Ave., Morrisville, PA 19067
215 736-0211
Syndicated radio programming.

MATRIX SYSTEMS CORP.
5177 Douglas Fir Rd., Calabasas, CA 91302
213 992-6776
Manual & computer-controlled MC switchers.

MATRIX VIDEO SERVICES, INC. ✓
727 Eleventh Ave., New York, NY 10019
212 265-8500
Teleproduction facilities, complete audio/video mobile unit & digital post-production services.

MATTHEWS STUDIO EQUIPMENT, INC. ✓
2405 Empire Ave., Burbank, CA 91504
213 843-6715
Mic stands, booms, dollies; camera tripods, heads, remote pan/tilt systems, cranes, dollies; quartz lighting fixtures, stands, rigging, diffusion & efx material.

MAXELL CORP. OF AMERICA ✓
60 Oxford Dr., Moonachie, NJ 07074
201 440-8020
Audio & videotape & cassettes.

MBB HELICOPTER CORP. ✓
Box 1607, West Chester, PA 19330
215 431-4150
ENG-equipped helicopters.

McCURDY RADIO ✓
1711 Carmen Dr., Elk Grove Village, IL 60007
312 640-7077
Mic mixers; mono, stereo, audio for TV mixing consoles; AM compressor/limiters; parametric equalizers & filters; turntables; hardwired intercoms; audio line, monitor & power amps, DAs, amp power supplies; au-

dio patch panels; low frequency extenders; PPM meters; digital, master & slave clocks; audio post-production services; radio & TV studio design.

MCG ELECTRONICS, INC. ✓
160 Brook Ave., Deer Park, NY 11729
516 586-5125
Surge protectors.

MCI, DIV. SONY CORP. OF AMERICA ✓
1400 W. Commercial Blvd., Fort Lauderdale, FL 33309
305 491-0825
Portable & studio mono/stereo consoles; automated & TV audio consoles; 2-, 4- & multitrack studio ATRs; SMPTE time code synchronizers.
[See ad on pgs. 22, 23](#)

MCI/QUANTEL ✓
Box 50810, Palo Alto, CA 94303
415 856-6226
Digital effects processors; digital art/paint systems, camera/VTR digitizers; compressor/positioner; character/graphics generators; digital still store; TBCs, field & frame synchronizers, noise reducers; digital standards converters; audio/video sync delay.
[See ad on pg. 24](#)

Refer to Reps/Distributors list
Field Offices:
CA (Southwest)
David Diels, Box 6098,
Canyon Lake 92380 . . . 714 679-7870
CA (Northwest)
Chuck Martin, Box 50810,
Palo Alto 94303 415 856-6226
CT (East)
David Derer, 300 Broad Street, #500,
Stamford 06901 203 348-4104
GA (Southeast)
Paul Fletcher, 2971 Flowers Rd. S.,
#106, Atlanta
30341 404 457-1266.
MI (Midwest)
Larry Biehl, 33701 Oak Point Circle,
Farmington Hills,
48018 313 553-2360
TX (South)
Greg Gambill, 4001 Airport Freeway,
Ste. 500K,
Bedford 76021 817 283-8944

McINNIS SKINNER & ASSOC. ✓
6529 Classen Blvd., Oklahoma City, OK 73116
405 848-4246
TV newsroom computers; character generators, digital art/paint systems, weather symbol inserters.

McKAY DYMEK, INC.
108 S. Spring St., Claremont, CA 91711
714 621-6711
Audio monitor speakers; AM & communications antennas.

McMANUS ENTERPRISES ✓
Box 6530, San Diego, CA 92106
619 223-1730
VTR rebuild ing service.

McMARTIN INDUSTRIES, INC. ✓
4500 S. 76 St., Omaha, NB 68127
402 331-2000

Imagine The Features That Will Answer Your Present And Future Needs ... Then Call **Di-Tech**

Audio/video routing switchers come in many different shapes and sizes, offering a variety of features. Since your requirements change from year to year, shouldn't you select the one that fits today's budget AND can meet your present and future needs? Then try **Di-Tech**. We've got that small 4 x 1 matrix switcher and the 200 x 200 switchers. We've even got a selection of in-between sizes for audio only, video only or audio follow video with 1, 2 or 3 channels of audio per input.....

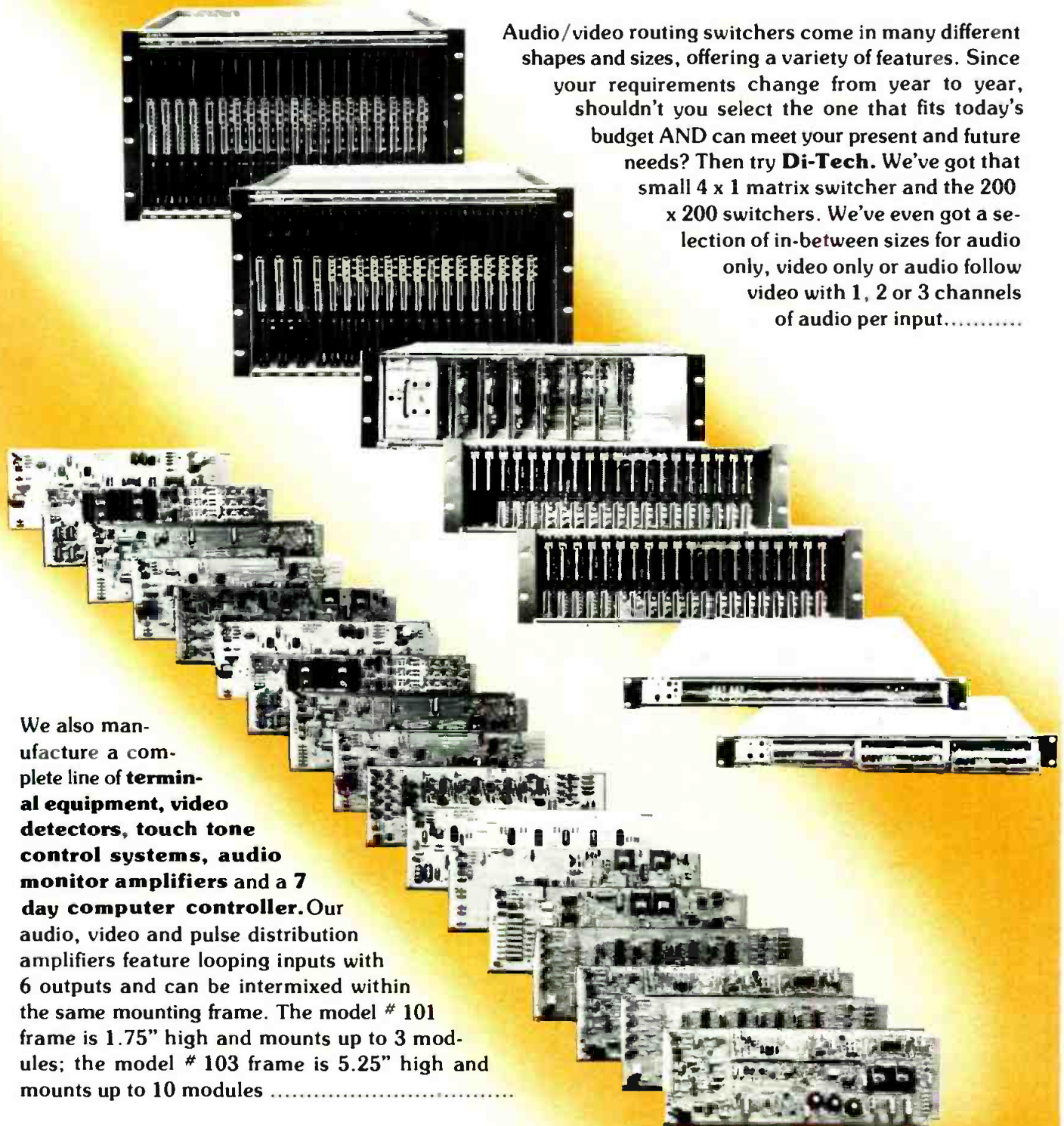

We also manufacture a complete line of **terminal equipment, video detectors, touch tone control systems, audio monitor amplifiers** and a **7 day computer controller**. Our audio, video and pulse distribution amplifiers feature looping inputs with 6 outputs and can be intermixed within the same mounting frame. The model # 101 frame is 1.75" high and mounts up to 3 modules; the model # 103 frame is 5.25" high and mounts up to 10 modules

Whatever your present or future needs are, call **Di-Tech** for the high quality, reliable, easy-to-operate answer.



di-tech

our **NEW**, bigger location:
48 JEFFRYN BOULEVARD
DEER PARK, N.Y. 11729
TEL. # (516) 667-6300

Manufacturers

Mic mixers; portable, mono & stereo, & audio for TV mixing consoles; graphic equalizers; AM & FM compressor/limiters; ALC & AGC amps; hardwired intercoms; line, monitor, power amps & preamps; VU meters; AM, FM, VHF, UHF & LPTV transmitters & translators; RF modulators, demodulators, stereo generators, amps; AM stereo, FM & TV exciters; AM, FM, TV (HP & CP) & comm. antennas, antenna tuning units; transmission line & connectors; towers; RF program subcarrier & carrier current systems; FM & TV SCA equipment; EBS two-tone systems; comm. monitors & receivers; remote control systems; remote pickup equipment; transmit/receive & receive only satellite earth stations; FM field intensity meters; frequency monitors & counters; modulation monitors.

McMICHAEL, LTD. ✓
Wexham Rd., Slough, Berks., SL2 5EL, England
(0753) 21610
Standards converters; broadcast color monitors; clock & logo generators.

MEAD DATA CENTRAL ✓
200 Park Ave., New York, NY 10166
212 883-8560
Computer-accessed library of wire service stories, newspapers, magazines.

MEDIA CONCEPTS, INC.
559 49 St. S., St. Petersburg, FL 33707
813 321-2122
Professional VHS VCRs, videocassette automation systems; foam insert transportation cases.

MEMOREX CORP. ✓
Box 988, Santa Clara, CA 95052
408 987-1343
Audio carts and cassettes; tape head cleaners; VHS & Beta videocassettes.

MERLIN ENGINEERING WORKS, INC. ✓
1880 Embarcadero Rd., Palo Alto, CA 94303
415 856-0900
Quad VTR refurbishing, replacement parts; one-inch B & C extended-play and high-band modifications; TBCs; color duplicators; standards converters.
[See ad on pgs. 14, 106](#)

METRO TAPE
5746 Sunset Blvd., Hollywood, CA 90028
213 856-1000
Teleproduction & video post-production facilities.

MICMIX AUDIO PRODUCTS, INC. ✓
2995 Ladybird Ln., Dallas, TX 75220
214 352-3811
Audio processing, mechanical reverb, noise reduction systems.

MICRO COMMUNICATIONS, INC. ✓
Box 4365, Manchester, NH 03108
603 624-4351
RF filters, loads & switches; power dividers, diplexers, combiners & portable microwave; FM, TV CP & microwave antennas; waveguide transmission line.

MICRO CONTROL ASSOCIATES, INC.
See Power Pak Systems

MICRO CONTROLS, INC. ✓
Box 728, Burleson, TX 76028
817 295-0965
AM & FM STL equipment; narrowband AM stereo STL; remote control equipment; SCA equipment.

MICRODYNE CORP. ✓
Box 7213, Ocala, FL 32672
904 687-4633
Satellite antennas, receivers & TV modulators; remote control systems.

MICROFLECT CO., INC. ✓
3575 25 SE, Salem OR 97302
503 363-9267
Guyed & self-supporting towers, reflectors, services.

MICRON AUDIO PRODUCTS, LTD. ✓
210 Westlake Dr., Valhalla, NY 10595
914 761-6520
RF, electret/condenser & lavalier mics.

MICROPROBE ELECTRONICS, INC./MEI
875 N. Michigan Ave., Ste. 1532A, Chicago, IL 60611
312 440-3111
Complete program automation systems, time insertion sequencers, computer automation controllers, radio business automation hardware.

MICROTIME, INC. ✓
1280 Blue Hills Ave., Bloomfield, CT 06002
203 242-4242
TBCs, frame synchronizers, framestores, TBC/framestores, digital effects, noise reducers, image enhancers; ad inserters.
[See ad on pg. 31](#)

Field Offices:
CA Frank Logan, Laguna Niguel
92677 714 495-6484
GA Jerry Rankin,
Lilburn 30247 404 979-4437
IL Dave Everett, Hoffman Estates
60195 312 934-9191
NJ Ray Bouchard, Lawrenceville
08648 609 896-3176
TX Steve Krant,
Richardson 75080 214 644-0232

MICRO-TRAK CORP. ✓
620 Race St., Holyoke, MA 01040
413 536-3551
Mic mixers; portable, mono & stereo & audio for TV mixing consoles; turntables, pickup arms, phono preamps, complete disc consoles; audio preamps, line, monitor & power amps, DAs; monitor speakers.

MICROTRAN CO., INC.
145 E. Mineola Ave., Box 236, Valley Stream, NY 11582
516 561-6050
Audio tape bulk erasers & head degaussers; full line transformers.

MICROWAVE FILTER CO., INC. ✓
6743 Kinne St., E. Syracuse, NY 13057

800 448-1666
Microwave & RF filters, traps, combiners & diplexers.

MICROWAVE GENERAL SYSTEMS ✓
110 L'Avenida Ave., Mountain View, CA 94043
415 969-3355
Satellite earth stations & receiving dishes.



MIDWEST CORP. ✓
1 Sperti Dr., Edgewood, KY 41017
606 331-8990
Mobile vehicle construction; custom turnkey systems; video, audio & RF components.
[See ad on pg. 15](#)

Field Offices:
FL Lloyd Hicks, 3331 N.W. 82 Ave.,
Miami 33122 305 592-5355
FL Bob Monacelli, 6302 Benjamin Rd., Ste.
403, Tampa 33614 813 885-9308
GA Ron Bradley, 522 Armour Circle, N.E.
Atlanta 30324 404 875-3753
IN Al Rerko, 8455 Keystone Crossing, Ste.
101, Indianapolis
46240 317 251-5750
KY David Barnes, One Sperti Dr.,
Edgewood 41017 606 331-8990
KY 2035 Regency Rd.,
Lexington 40503 606 277-4994
KY John Loughmiller, 1804 Cargo Ct.,
Louisville 40299 502 491-2888
MD John Handley, 4720 B Boston Way,
Lanham 20801 301 577-4903
MI Ed Ziemba, 1328 Wheaton Ave.,
Troy 48084 313 689-9730
NC Marsha Pleasants, 2848 Ste. E,
Interstate 85 South,
Charlotte 28208 704 399-6336
OH Fred Higbie, 4410 Westerville Rd.,
Columbus 43229 614 476-2800
OH Brad Nogar, 7500 Wall St.,
Cleveland 44125 216 447-9745
OH Dennis Wright, 1540 Bowman Ave.,
Dayton 45409 513 298-0421
PA John Humphrey, Box 415,
Gibsonia 15044 412 781-7707
TN Lonnie Lindsey, 2405 Windsor Ave.,
Bristol 37620 615 968-2289
TN Fred McCoy, A7-156 Space Park
South, Antioch Pike, Nashville
37211 615 331-5791
VA Elijah Midkill, 1395 Air Rail Ave., Vir-
ginia Beach 23455 804 464-6256
WV Jack Crouse, 307 Sandy Blvd.,
Clarksburg 26301 304 624-5459
WV David Foglesong, 300 First Ave.,
Nitro 25143 304 722-2921

L. MATTHEW MILLER ASSOC., LTD.
48 W. 21 St., New York, NY 10010
800 221-9328
Video production & post-production equip-
ment rentals & sales.

MILAM AUDIO CO. ✓
1470 Valle Vista St., Tekin, IL 61554
309 346-3161
Audio studio design services; audio DAs.

Camera Mart and Listec.

Broadcast Quality Support Equipment.

What's in the name? Plenty! Listec is the name for superbly engineered mounting and monitor prompting equipment that has won the Guild of Television Cameramen's award. And Camera Mart is the name for personalized knowledgeable service that has won the respect of the industry's top professionals. So check out New York's most extensive collection of Listec equipment at Camera Mart. Two great names you can rely on.



PORTAPED
A combination self leveling portable pedestal with a built-in pneumatic column for in shot elevations. 120 lb. capacity. Adjustable legs for both height and direction, lifting ring, carrying handle, column lock and adjustable drag controls.

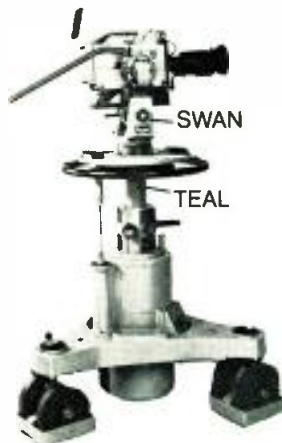

SWAN POST PAN AND TILT HEAD A new concept of camera mounting that allows any portable camera to swing on its own center of gravity.
TEAL PNEUMATIC LIGHTWEIGHT PEDESTAL A lightweight pneumatic 140 lb. capacity pedestal designed for a wide range of portable and intermediate size color cameras.



LISTEC MONITOR PROMPTING SYSTEMS A lightweight, broadcast engineered, black and white monitor, hood and semi-transparent high quality mirror, weight 22 pounds. Used by network and major broadcasting stations.



MARK II PETREL PAN AND TILT HEAD A high load capacity to weight ratio and adjustable center of gravity compensator is available on this pan and tilt head and is ideal for intermediate size cameras. 100 lb. capacity.

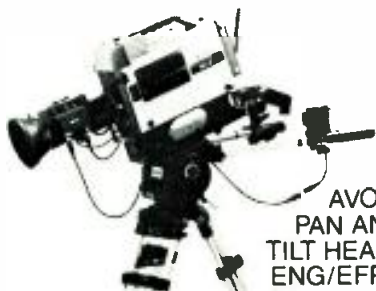

AVOCET PAN AND TILT HEAD Lightweight ENG/EFP Pan and Tilt heads featuring a revolutionary development in tilt control essential for critical and narrow angle shots on ENG and EFP applications. 30 lb. capacity with 180° tilt range.

MARK 3A CAM HEAD A heavy duty cam head with a weight ratio of up to 400 lbs. allowing the use of a wide range of cameras, multi-range zoom lenses and prompter systems.



FULMAR EXTENDED RANGE PNEUMATIC PEDESTAL Unsurpassed for stability, heavy weight capacity, finger tip control.

The Camera Mart, Inc.

456 West 55th Street, New York 10019 • (212) 757-6977/Telex: 1-2078
Video Department: 800 Tenth Avenue
Sales • Service • Rental

Circle 177 on Reader Service Card

THE INNOVATORS

Innovative design, engineered exclusively for the broadcast industry make STOREEL's high-density storage systems the practical solution for all your storage problems.

Convert your overcrowded film and VTR libraries into a STOREEL "instant-access" storage system built to your specific needs and requirements.



"The Room Stretcher"



"The Railrider"

Built on a patented track-system, STOREEL's modular shelving maximizes the tape and film stored per square foot of floor space while minimizing costly retrieval time.



call or write:

STOREEL CORP.
THE SPACE-SAVING ENGINEERS

2050 C Carroll Ave., P.O. Box 80623, Atlanta, GA. 30341
(404)458-3280

Circle 178 on Reader Service Card

Manufacturers

MILLER PROFESSIONAL EQUIPMENT, INC. ✓
10816 Burbank Blvd., N. Hollywood, CA 91601

213 766-9451
Tripods, heads & dollies.

MINICOM ✓
Box 302, Walnut Creek, CA 94596
415 932-8134
Hardwired intercoms.

MINNEAPOLIS MAGNETICS, INC. ✓
7178 Shady Oak Rd., Eden Prairie, MN 55344
612 944-7660
Replacement audio & video heads; VTR re-building service.

MINOLTA CORP. ✓
101 Williams Dr., Ramsey, NJ 07446
201 825-4000
Light meters, illuminance meters, luminance meters, color temperature meters, chroma meters, TV monitor analyzers.
See ad pg. 20

MITSUBISHI ELECTRIC SALES AMERICA, INC. ✓
110 New England Ave. W., Piscataway, NJ 08854
800 631-5377
Fixed head, open-reel digital audio recorder; digital audio recorder rental service.

MOBILE TECHNICAL SERVICES, INC. ✓
129 Mt. Auburn St., Cambridge, MA 02138
617 547-3320
Mobile teleproduction facility.

MOBILE VIDEO PRODUCTIONS ✓
888 Post St., San Francisco, CA 94109
415 386-1188
Studio & mobile teleproduction facilities; video post-production facility.

MOBILE VIDEO SERVICES, LTD. ✓
2139 Wisconsin Ave., NW, Washington, DC 20007
202 298-9100
Studio & mobile teleproduction facilities; video post-production facility.

MODERN TELECOMMUNICATIONS, INC. (MTI) ✓
1 Dag Hammarskjold Plaza, New York, NY 10017
212 355-0510
Studio & mobile teleproduction facilities; video post-production facility.

MODULAR AUDIO PRODUCTS ✓
50 Orville Dr., Bohemia, NY 11716
516 567-9620
Compressor/limiters, graphic equalizers; audio preamps, line, monitor & power amps,

DAs, amp power supplies; oscillators; switcher cards; Impac & Europac plug-in & rack-mount equipment; audio jackfields.

MODULATION ASSOCIATES ✓
897 Independence Ave., Mountain View, CA 94043
415 962-8000
Transmit/receive & receive only satellite earth stations.

MODULATION SCIENCES, INC. ✓
99 Myrtle Ave., Brooklyn, NY 11201
212 625-7333
Signal processors; control equipment for radio. Composite line drivers, FM stereo composite limiter; STLs; SCA generators.

MOLE-RICHARDSON CO. ✓
937 N. Sycamore Ave., Hollywood, CA 90038
213 851-0111
HMI & quartz fixtures, lighting stands & rigging, lighting control boards, dimmer packs & diffusion material, cyc lighting; generators.

KEITH MONKS AUDIO ✓
652 Glenbrook Rd., Stamford, CT 06906
203 348-4969
Record cleaning systems; mic stands, booms & dollies. Impedance bridges; phase meters.

MONROE ELECTRONICS, INC. ✓
100 Housel Ave., Lyndonville, NY 14098
716 765-2254
Telco interface equipment.

MOOG MUSIC, INC. ✓
2500 Walden Ave., Buffalo, NY 14225
716 681-7200
Music synthesizers.

MOSELEY ASSOCIATES, INC. ✓
111 Castilian Dr., Goleta, CA 93117
805 968-9621
ALC & AGC amps, AM & FM compressor/limiters. RF power dividers, stereo generators; intercity microwave; remote control systems; microwave STLs; FM & TV SCA equipment; RF program subcarrier. Log printers, status & alarm indicators.
See ad on pgs. 102, 103

MOTOROLA, INC. ✓
1216 Remington, Schaumburg, IL 60195
312 576-2879
AM stereo exciters; AM stereo modulation monitors.
See ad on pg. 97

MOTOROLA C&E, INC. ✓
17-22 Whitestone Expy., Whitestone, NY 11357
212 746-1100
RF intercom systems; remote pickup equipment; two-way radio communications transmitters, receivers & antennas. RF power meters & wattmeters, frequency monitors & controllers, RF test signal generators; spectrum analyzers; oscilloscopes, delayed sweep scopes, voltmeters, multimeters, dB meters, logic analyzers. RF cable, connectors; solid state components; quartz crystals.

MPB TECHNOLOGIES, INC. ✓
1725 N. Service Rd., Transcanada Hwy.,

✓ MEANS IT'S VERIFIED

When you
absolutely,
positively,
unequivocally,
categorically
need to look
your best.

FUJI
VIDEO TAPE
MADE IN JAPAN

Available in 2", 1", 3/4" and 1/2" Beta and VHS.



© 1981 Fuji Photo Film U.S.A., Inc., Magnetic Tape Division, 350 Fifth Avenue, NY, NY 10118

Circle 179 on Reader Service Card

www.americanradiohistory.com

Manufacturers

Dorval, Que. H9P 1J1 Canada
514 683-1490
Video animation controllers; character generators.

MPCS VIDEO IND., INC. ✓
514 W. 57 St., New York, NY 10019
212 586-3690
Production equipment rentals; post-production services; TV studio design; video camera & monitor modification; distributor of full line video equipment.

MU-DEL ELECTRONICS, INC. ✓
2426 Linden Ln., Silver Spring, MD 20910
301 587-6087
RF amplifiers, attenuators, converters & filters; diplexers.



MULTIDYNE ELECTRONICS ✓
Box 528, Locust Valley, NY 11560
516 671-7278
Audio preamps, line amps, DAs. Character generators; downstream keyers; SMPTE time code generators, readers & synchronizers, proprietary time code systems; sync, black burst, color bar, multiburst, staircase ramp, source ID & countdown generators; video slate board; video signal, cable equalizers; video pulse amps, DAs, SC amps; video test signal generators.

MULTI-TRACK MAGNETICS, INC. ✓
3 Industrial Ave., Upper Saddle River, NJ 07458
201 327-9400
Sprocketed magnetic film transports, dubbers; replacement audio heads, alignment & tension gauges; film/video synchronizers. Telecines, 16/35 mm telecine projectors.

MULTIVISION, INC. ✓
161 Highland Ave., Needham, MA 02194
617 449-5830
Mobile teleproduction facility; video post-production facility.

MUSIC DIRECTOR PROGRAMMING SERVICE ✓
Box 103, Indian Orchard, MA 01151
413 783-4626
Syndicated radio programming; popular & country oldies libraries; recording studio; music research books, music playlists.

THE MUSICWORKS, INC. ✓
Box 111390, Nashville, TN 37211
800 251-9000
Syndicated radio programming; radio consultant.

MXR INNOVATIONS, INC. ✓
740 Driving Park Ave., Rochester, NY 14613
716 254-2910
FM compressor/limiters, graphic equalizers; digital special effects, delay & reverb; analog special effects; audio pitch shifter; audio preamps.

NADY SYSTEMS ✓
1145 65 St., Oakland, CA 94608
415 652-2411
RF intercom systems, RF & lavalier mics.

NAGRA MAGNETIC RECORDERS, INC. ✓
19 W. 44 St., Rm. 715, New York, NY 10036
212 840-0999
Portable ATRs, 2,4-track studio ATRs; tape duplicators; replacement audio heads, head degaussers; audio test tapes; tape-based loggers, chart recorders.

NATIONAL VIDEO CENTER/RECORDING STUDIOS, INC. ✓
460 W. 42 St., New York, NY 10036
212 279-2000
Studio & mobile teleproduction facilities; video post-production facility; complete audio facilities.

NATIONAL VIDEO INDUSTRIES ✓
15 W. 17 St., New York, NY 10011
212 691-1300
Video post-production facility.

NAUTICAL ELECTRONIC LABS, LTD. (NAUTEL MAINE) ✓
RR 1, Pantallon, Nova Scotia, Canada B0J 3J0
902 823-2233
AM transmitters; RF amps, AM & AM stereo exciters, stereo generators, modulators.
[See ad on pg. 130](#)
Field Office:
ME Nautel Maine Inc., 201 Target Ind. Cir.
Bangor 04401 207 947-8200

NEC AMERICA, INC., BROADCAST EQUIPMENT DIV. ✓
130 Martin Ln., Elk Grove Village, IL 60007
312 640-3792
ENG/EFP video cameras; CCD cameras; digital video effects processors, standalone effects generators; parallel & serial interface routing switchers; frame synchronizers; signal multiplexers. FM, UHF & VHF transmitters; FM exciters; receive only satellite earth stations; portable ENG microwave; freeze frame transceivers.
[See ad on pgs. 75, 183](#)
Refer to Reps/Distributors section
Field Offices:
CA Frank Stolten, 1012 Stewart Dr., Sunnyvale 94086 408 737-7711
NJ Lawrence Litchfield, 21 Brandywine Terr., Morristown
07690 201 540-0819

NEI ✓
934 NE 25 Ave., Portland, OR 97232
503 232-4445
Mic mixers; portable, mono & stereo audio consoles; parametric & graphic equalizers; analog & mechanical special effects, reverb. Real time & spectrum analyzers.

NES, INC. (NATIONWIDE ELECTRONICS SYSTEMS) ✓
1536 Brandy Pky., Streamwood, IL 60103
312 289-8820
Digital clocks, master & slave clocks, timers, digital instrumentation products.

NET ENTERPRISES
3200 Eisenhower Pkwy, Ste. Q, Ann Arbor, MI 48104
313 971-0031
Studio & mobile teleproduction facilities; video post-production facility.

NETCOM INTERNATIONAL ✓
1702 Union St., San Francisco, CA 94123
415 921-1441
Satellite time sales, transportable downlink service, network coordination.

NETWORK PRODUCTION MUSIC, INC. ✓
4429 Morena Blvd., San Diego, CA 92117
619 272-2011
Production music library & sound effects.

NEUMADE PRODUCTS CORP. ✓
Box 568, Scarsdale, NY 10583
914 725-4900
Audio carts, sprocketed magnetic film, empty reels & carts, tape loaders, tape timers & rewinders; tape storage units.

NEUTRIK PRODUCTS ✓
77 Selleck St., Stamford, CT 06902
203 348-2121
Graph recorder; audio test signal generators & harmonic distortion meters; audio cable & connectors; transformers.

RUPERT NEVE, INC. ✓
Berkshire Industrial Park, Bethel, CT 06801
203 744-6230
Mic mixers; portable, mono & stereo consoles, automated post-production & TV mixing consoles; limiter/compressors; audio line amps, DAs; facility turnkey installations.
[See ad on pg. 133](#)
Refer to Reps/Distributors
Field Office:
CA 7533 Sunset Blvd.,
Hollywood 90046 213 874-8124

NEW ENGLAND SATELLITE SYSTEMS ✓
45 Drury Ln., Worcester, MA 01609
617 757-2531
Transportable satellite earth station rentals; site surveys; permanent installation services.

NEWSCAN
See McInnis Skinner

NEXUS PRODUCTIONS, INC. ✓
10 E. 40 St., New York, NY 10016
212 679-2180
Video post-production facility.

NIDUS BROADCAST SYSTEMS
See Paul Adams & Assoc.

NIKKO AUDIO ✓
320 Oser Ave., Hauppauge, NY 11788
516 231-8181
Mono & stereo audio consoles; audio preamps & power amps; graphic & parametric equalizers; turntables; integrated amps; time delay synthesizers; cassette decks.

FRED A. NILES COMMUNICATIONS, INC. ✓
1058 W. Washington Blvd.,

Why Beyer mics represent a viable alternative to the usual choices in Broadcast.



Beyer MCM Condenser System



Beyer MCE 5 Lavalier



Beyer M 260

Now there's another high-tech German condenser system.



Until recently, film and broadcast engineers thought only Sennheiser and Neumann made high-quality condenser microphone systems. Now the Beyer MCM Series offers the same German excellence in design and construction, the same kinds of accessories (windscreens, pistol grips, shock mounts) and facilities for 12V and 48V "phantom" powering.

And since the MCM Series studio condenser mic is part of a system which combines power modules and different mic capsules (long shotgun, short shotgun, unidirectional, omnidirectional and figure eight), you get more microphone potential for dollar output.

Like all Beyer microphones, the MCM Series is a truly professional instrument system suited to the widest range of applications in Broadcast/Film and Video post-production.

With lavalier mics, small is not enough.



Electret condenser lavalier mics like SONY's ECM-50 have proven useful for on-camera miking situations because of their reduced size. And while many of these mics offer good performance in a compact size, the Beyer MCE5 also provides extended frequency response (20 to 20,000 Hz) and durability in an even smaller format (diameter: 7 mm / length: 23 mm).

To optimize its compatibility with a variety of broadcast and film applications, the tiny black MCE5 is available in different configurations for powering interface and includes a system with accessories like windscreens, expansion mounts etc.

At Beyer Dynamic's ultra-modern manufacturing facility in West Germany, we hand-build virtually all of our microphones in the most evolved state of fine German engineering.

There's more than one way to bring out the warmth in an announcer's voice.



Broadcast engineers choose the E-V RE20 for many vocal announcing situations because of its wide frequency response (45-18,000 Hz)* and smooth sound. Beyer Dynamic's M 260 also provides the extended frequency response (50-18,000 Hz) and warmth required for critical vocal applications with one distinct advantage: its reduced size. Its compact and efficient ribbon element captures the warmth traditionally provided by this type of mic. And because it is considerably smaller than a mic with a large moving-coil diaphragm, the M 260 provides a natural, balanced sound image in a portable format that won't obscure copy or take up valuable space in the studio.

The Beyer M 260 has its own custom-designed ribbon element to optimize the mic's performance based on its Broadcast applications.

The Dynamic Decision

beyerdynamic

*Extracted from competitive promotional literature or advertising.

*Documentation supporting specific comparative claims available upon request.

Beyer Dynamic, Inc. 5-05 Burns Avenue, Hicksville, New York 11801 (516)935-8000

Circle 180 on Reader Service Card

www.americanradiohistory.com

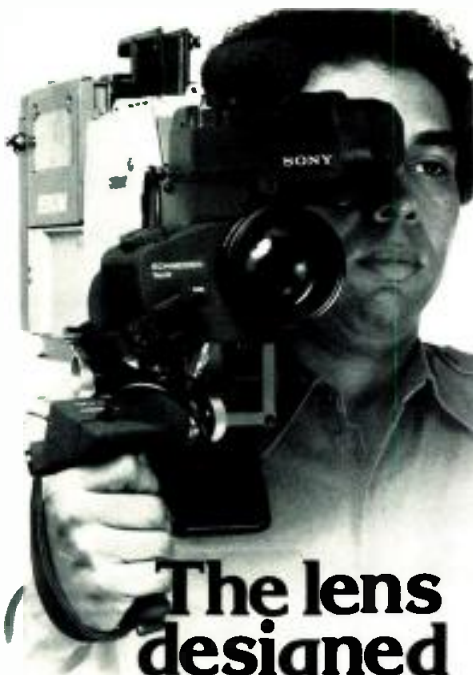

The lens designed with the cameraman in mind.

The Schneider 14X ENG/EFP lens is economical, light-weight, and has all the features it should have. It brings out the best in the best cameras available today.

This lens is packed with conveniences that help the cameraman get the most out of every situation. It has a pistol-grip with built-in iris control that has all controls available within a thumb's touch. It has a generously sized rocker control that makes it easier to control the zoom. And because the iris and zoom electronics are in a weather-resistant housing, there are no shorts from moisture in the field.

The lens can power zoom from 9mm to 126mm. Or with the 2X built-in extender from 18 to 252mm. With the low distortion 6.3mm, to 9mm aspheric lens attachment, it can power zoom on the super wide angle shots. Schneider broadcast lenses are available throughout the United States and Canada from:

Tele-Cine Corp.
400 Crossways Park Drive
Woodbury, NY 11797
(516) 496-8500

Schneider

14X ENG/EFP

Tele-Cine Corp. is a subsidiary of
Schneider Corporation of America

Circle 181 on Reader Service Card

Manufacturers

Chicago, IL 60607
312 738-4181
Studio & mobile teleproduction facilities; video post-production facility.

NORTH AMERICAN VIDEO & BROADCASTING, INC.
1726 Cherry St., Philadelphia, PA 19103
215 854-0900
Studio & mobile teleproduction facilities; video post-production facility.

NORTHEAST PRODUCTIONS (NEP)

Wilkes-Barre/Scranton Int'l Airport, Avoca, PA 18641
800 233-4777
Mobile teleproduction facility; video post-production facility.
[See ad on pg. 164](#)
Field Offices:
NY Erick Thomas, NEP Sharpshooters Inc.,
56 W. 45th St.,
New York 10036 212 823-1100
PA John Glaive, Wilkes-Barre/Scranton
Int'l Airport,
Scranton 18641 800 233-4777

NORTH HILLS ELECTRONICS, INC.
Glen Cove, NY 11542
516 671-5700
Video filters; signal multiplexers. RF power dividers; microwave STLs; hum bucking coils.

NORTH WIND POWER CO., INC.
Box 556, Moretown, VT 05660
802 496-2955
Wind energy systems; lead-acid batteries & chargers; generators, inverters & converters; towers & masts.

NORTHWEST COMMUNICATIONS, LTD.
5381 48 Ave., Delta, BC V4K 1W7, Canada
604 946-1146
Studio & mobile teleproduction facilities; video post-production facility.

NORTHWEST TELEPRODUCTIONS, INC.
4455 W. 77 St., Minneapolis, MN 55435
612 835-4455
Studio & mobile teleproduction facilities; video post-production facility.

NORTRONICS CO., INC.
8101 Tenth Ave. N., Minneapolis, MN 55427
612 545-0401
Audio & video replacement heads, head cleaners & evaluators; alignment & tension gauges; bulk erasers; audio tape cleaners & evaluators; splicing blocks, tape. Manual master control switchers.

N.O.V.A. CORP.
5801 Uplander Way, Culver City, CA 90230
213 641-2046
Videotape cleaners, evaluators.

N-PRO
10022 Hazelwood Dr., Oregon City, OR 97045
503 656-5500
Hydraulic ENG vehicle masts.

NTI AMERICA, INC.
1680 N. Vine St., Ste. 202, Los Angeles, CA 90028
213 462-8945
Digital video test signal generators; video color time coder; digital still store.

FRED A. NUDD CORP.
1743 Rt. 104, Box 475, Ontario, NY 14519
315 524-2531
AM antennas; towers & masts, tower hardware & construction equipment; engineering consultant.

NURAD, INC.
2165 Druid Park Dr., Baltimore, MD 21211
301 462-1700
Intercity, portable ENG & airborne microwave, central receivers; remote control systems; microwave STLs; microwave antennas.

NYTONE ELECTRONICS CORP.
2424 S. 900 West, Salt Lake City, UT 84119
801 973-4090
16/35 mm telecine projectors, optical multiplexers, telecine color correctors.

N-Z VIDEO SYSTEMS
513 Greer Ave., Sikeston, MO 63801
314 471-7145
Facility turnkey installations; mobile vehicle construction.

OAK COMMUNICATIONS, INC., CATV DIV.
100 S. Main St., Crystal Lake, IL 60014
815 459-5000
Decoders, converters & addressable systems for STV, PTV, & CATV.

O'CONNOR ENGINEERING LABS, INC.
100 Kalmus Dr., Costa Mesa, CA 92626
714 979-3993
Tripods, heads & pedestals.

ODETICS, INC.
1380 S. Anaheim Blvd., Anaheim, CA 92805
714 774-5000
Fixed head digital audio recorders; cassette player/recorders, duplicators; replacement heads, cassettes, bulk erasers; dynamic & condenser mics, booms. Video cassettes; digital, master/slave clocks, timers.

OKI ELECTRIC OVERSEAS CORP.
1 University Plaza, Hackensack, NJ 07601
201 646-0011
Digital standards converters; satellite receive only earth stations.
[See ad on pg. 123](#)

OKTEL CORP.
490 Division St., Campbell CA 95008
408 374-1811
Slow motion videodisc recorders & microprocessor controllers with computer interface; monochrome cameras.

OLD DOMINION BROADCAST ENG. SVCS.
1101 Front St., Richmond, VA 23222
804 321-4506

Studer Re-States the Art



With the new A810, Studer makes a quantum leap forward in audio recorder technology. Quite simply, it re-states the art of analog audio recording.

By combining traditional Swiss craftsmanship with the latest microprocessor control systems, Studer has engineered an audio recorder with unprecedented capabilities. All transport functions are totally microprocessor controlled, and all *four* tape speeds (3.75 to 30 ips) are front-panel selectable. The digital readout gives real time indication (+ or - in hrs, min, and sec) at all speeds, including vari-speed. A zero locate and one autolocate position are always at hand.

That's only the beginning. The A810 also provides three "soft keys" which may be user programmed for a variety of operating features. It's your choice. Three more locate positions. Start locate. Pause. Fader start. Tape dump. Remote ready. Time code enable. You can program your A810 for one specialized application, then re-program it later for another use.

There's more. Electronic alignment of audio parameters (bias, level, EQ) is accomplished via digital pad networks. (Trimpots have been eliminated.) After programming alignments into the A810's memory, you simply push a button to re-align when switching tape formulations.

The A810 also introduces a new generation of audio electronics, with your choice of either transformerless or transformer-balanced in/out cards. Both offer advanced phase compensation circuits for unprecedented phase linearity. The new transport control servo system responds quickly, runs cool, and offers four spooling speeds.

Everything so far is standard. As an option, the A810 offers time-coincident SMPTE code on a center track between stereo audio channels. Separate time code heads ensure audio/code crosstalk rejection of better than 90 dB, while an internal digital delay automatically compensates for the time offset at all speeds. Code and audio always come out together, just like on your 4-track. Except you only pay for 1/4" tape.

If you'd like computer control of all these functions, simply order the optional serial interface. It's compatible with RS232, RS422, and RS422-modified busses.

More features, standard and optional, are available. We suggest you contact your Studer representative for details. Granted, we've packed a lot into one small package, but ultimately you'll find that the Studer A810 is the most versatile, most practical, most *useable* audio recorder you can buy.

The Swiss wouldn't have it any other way.



STUDER REVOX
PRECISION FROM SWITZERLAND

Studer Revox America, Inc. • 1425 Elm Hill Pike, Nashville, TN 37210 (615) 254-5651
Offices: Los Angeles (213) 780-4234 • New York (212) 255-4462 • Dallas (214) 760-8647 • Canada: Studer Revox Canada, Ltd.

Circle 182 on Reader Service Card
www.americanradiohistory.com

Manufacturers

Telco interface equipment; equipment rental, facility turnkey installations, studio set design services.

OLESEN ✓
1535 Ivar Ave., Hollywood, CA 90028
213 461-4631

Lamps, fixtures, scenery, rigging, lighting stands; lighting control boards & dimmer packs; diffusion, efx material; ac cables & connectors.

OMICRON VIDEO ✓
22251 Roscoe Blvd., Canoga Park, CA 91304

213 884-1268
Video DAs; switchers; edit controllers; sync generators.

OMNIMOUNT SYSTEMS ✓
10850 Vanowen St., N. Hollywood, CA 91605
213 766-9000

Mounting assemblies for monitor speakers & other broadcast equipment.

ONAN CORP. ✓
1400 73 Ave. NE, Minneapolis, MN 55432
612 574-5000

Power generators.

ONE PASS FILM AND VIDEO ✓
1 China Basin Bldg., San Francisco CA 94107

415 777-5777
Studio, mobile teleproduction facilities; video, audio post-production facilities.

OPAMP LABS, INC. ✓
1033 N. Sycamore Ave., Los Angeles, CA 90038

213 934-3566
Mic mixers; portable, mono & stereo, audio for TV mixing consoles; graphic equalizers, reverb & noise reduction. Power, line & monitor amps, amp power supplies; VU meters; rotary & slide attenuators. Video DAs & pulse amps.

OPRYLAND PRODUCTIONS
2806 Opryland Dr., Nashville, TN 37214
615 889-6840

Studio & mobile teleproduction facilities; post-production facility.

OPTIMA ENCLOSURES, DIV. SCIENTIFIC-ATLANTA ✓

2166 Mountain Industrial Blvd., Tucker, GA 30084

404 939-6340
Racks, equipment enclosures, cabinets.

OPTIMUS

161 E. Grand, Chicago, IL 60611

312 321-0880
Teleproduction & video post-production facilities.

URBAN ASSOCIATES, INC. ✓

645 Bryant St., San Francisco, CA 94107
800 227-4498/415 957-1067 in CA

AM & FM compressor/limiters; graphic & parametric equalizers & filters; special effects & mechanical reverb; AM, FM & TV processors & stereo generators.

See ad on pgs. 19, 180

Refer to Reps/Distributors section

ALLEN OSBORNE ASSOC. ✓

5195 N. Douglas Fir Rd., Calabasas, CA 91302

213 888-2772

Telescoping & pneumatic towers & masts.

See ad on pg. 142

OSRAM SALES CORP. ✓

Box 7062, Jeanne Dr., Newburgh, NY 12550
914 564-6300

HMI lamps & lighting fixtures.



OTARI CORP. ✓

2 Davis Dr., Belmont CA 94002

415 592-8311

Open-reel portable, studio & multitrack ATRs; tape duplicators, loaders; video-cassette loaders.

See ad on pg. 58

PACE WIRE & CABLE CORP. ✓

3590 Oceanside Rd., Oceanside, NY 11572
516 678-2275

Wire and cable, tools.

PACIFIC COAST VIDEO ✓

635½ Chapala, Santa Barbara, CA 93101
805 965-5015

Teleproduction & video post-production facilities.

PACIFIC RECORDERS & ENGINEERING CORP. ✓

2070 Las Palmas Dr., Carlsbad, CA 92008
619 438-3911

Stereo audio consoles; single deck cart player/recorders & phase control matrixing; audio DAs.

See ad on pg. 55

PACIFIC VIDEO

809 N. Cahuenga Blvd., Los Angeles, CA 90038

213 462-6266

Studio & mobile teleproduction facilities; video post-production facility.

PACKAGED LIGHTING SYSTEMS, INC. ✓

Box 285, Grant St., Walden, NY 12586
914 778-3515

Lighting stands, rigging, dimmer packs; quartz fixtures, cyc lighting & power systems.

W.A. PALMER FILMS, INC. ✓

611 Howard St., San Francisco, CA 94105
415 986-5961

Telecines & video/film recording cameras; film lab services; film-to-tape transfers; audio post-production facility & recording studio; music library.

PANASONIC INDUSTRIAL CO. ✓

1 Panasonic Way, Secaucus, NJ 07094
201 348-7000

Field, ENG/EPF, single tube, single piece & monochrome cameras; effects generators, colorizers, chromakeyers & downstream

keyers; editor/controllers, SMPTE time code generators & readers; sync & color bar generators; pulse amps, video DAs; monochrome, NTSC, RGB, dc portable monitors & video projectors; videotape & cassettes.

PANAVISION ELECTRONICS ✓

880 Maude Ave., Mountain View, CA 94043
415 969-1910

Field, electronic cinematography, EFP cameras, lenses; telecine cameras.

PARSONS MFG. CORP. ✓

1055 O'Brien Dr., Menlo Park, CA 94025
415 324-4726

Foam insert transportation cases, equipment carriers.

PD MAGNETICS

Box 4499, Wilmington, DE 19807

302 999-4253

Audio cassettes; videotape.

PEAK AUDIO ✓

3107 Bedlington Pl., Holland, PA 18966
215 860-0303

Retrofittable tape timer accessory for ATRs; solid state replacement for Raysistor on Scully 280B; repair & refurbishing of audio equipment.

PEIRCE-PHELPS, INC. ✓

2000 N. 59 St., Philadelphia, PA 19131
215 879-7171

Facility turnkey installations & mobile vehicle construction.

PENNY & GILES ✓

1640 Fifth St., Santa Monica, CA 90401
213 393-0014

Audio rotary & slide attenuators.

PENTAGON INDUSTRIES, INC. ✓

4751 N. Olcott, Chicago, IL 60656
312 867-9200

Audio cassette player/recorders, changers & duplicators; alignment gauges; tape rewinders.

PEP, INC. ✓

25 W. 54 St., New York, NY 10019
212 246-2490

Nicad batteries & chargers; ac adapters.

PERROTT ENGINEERING LABS, INC. ✓

7201 Lee Hwy., Falls Church, VA 22046
703 532-0700

Nicad, silver-zinc & lead-acid batteries & chargers; accessory ENG & EFP equipment; portable lights, communication batteries; quartz crystals.

See ad on pg. 52

PETERS PRODUCTIONS, INC. ✓

9590 Chesapeake Dr., San Diego, CA 92123
619 565-8511

Audio post-production facility & recording studio; promotions & advertising.

PHASECOM CORP.

6365 Arizona Circle, Los Angeles, CA 90045
213 641-3501

Heterodyne TBCs; modulators & demodulators; videocassette automation systems; HRC head end equipment.

TOWNSEND

The Television Transmission Specialists

Running a straight course keeps Townsend a step or two ahead of the competition.

The many opportunities in television have attracted several of today's largest corporations into our industry from a variety of backgrounds. Since the beginning, Townsend Associates has been dedicated to the design, development, and manufac-

ture of television transmission equipment exclusively. It's not a sideline with us. And we're not someone else's subsidiary. From transmitters to components, everything we develop and produce is mainstream to the transmission of television.

INNOVATIONS THROUGH SPECIALIZED R&D

High Power UHF & VHF Television Transmission

FIRST solid state exciter.

FIRST to employ emergency klystron multiplex circuitry for UHF.

Low Power UHF And VHF Transmission Systems

FIRST manufacturer of High Power transmitters for L.P.T.V.

FIRST integrated antenna and amplifier transmission system for low power UHF.

Satellite Rebroadcast Systems

FIRST transmitter manufacturer to introduce satellite system concept through a cooperative effort with a TVRO manufacturer.

FIRST to have a complete line of transmitters for satellite rebroadcast systems. We design and build rebroadcasting systems for UHF and VHF and each is available in either low or high power configurations.

Multipoint Distribution Service (MDS) And ITFS

FIRST 100% solid state transmitters in both 10 watt and 100 watt.

FIRST with intermod free external duplexing of the aural and visual carriers.

Custom Engineering

FIRST and only manufacturer with hardware and the know-how to up-power all major brands of T.V. transmitters.

Major Components

FIRST solid state pulser.

FIRST to introduce external cavity klystrons.

FIRST to provide a regulated and adjustable power supply...PERVEAC.

FIRST to manufacture and employ plug in vacuum contactors for T.V. transmitters.



The R & D Group Our "FIRST" Team,

The many transmission innovations developed by the Townsend R & D group have often involved technologies borrowed from other fields. Their singular purpose is to find ways to measurably raise the state-of-the-art in just one field...television transmission.

TOWNSEND

ASSOCIATES, INC.

79 Mainline Dr., Westfield, MA 01085 Tel. 413-568-9581 TWX #710-356-1521 • West Coast: 1080 Los Molinos Way, Sacramento, CA 95825 • Bangkok: Box 11-1240, Nana, Thailand 10112 • Canada: Comad Comm., 91 Kelfield St., Rexdale, Ontario M9W 5A3 • Australia: TBC PTY. Ltd., 6 Chilvers Rd., Thornleigh, N.S.W. 2120

Circle 183 on Reader Service Card

www.americanradiohistory.com



Modular Tape Synchronizers!

Buy only what you need! From basic audio-audio/audio-video record and layback, through multi-slate chase operations for mixing, right up to television sound editing, SYSTEM 2600 will precisely fill your immediate requirements.

Add modules as you grow! With SYSTEM 2600, you can expand without ever obsoleting equipment you've already purchased.

And every SYSTEM 2600 synchronizing combination gives you: 1/100-frame offset adjustment • DC and FM capstan control • internal interfacing (no extra boards or hidden costs) • "Smart-Lock" fast re-synchronizing • tach pulse/control track updating • automatic drop-frame offset calculation • "Splice-Trap" • NV data retention through power-down • LTC, VITC or pilot tone • NTSC, PAL and SECAM.

Also available: separate, remote-able, Master, Slave, Event/Edit and Data Entry control panels for cueing, looping, and trimming • LED and video monitor display • computer interfacing.

Call or write for complete details! Dealer inquiries cordially invited.



ADAMS-SMITH

34 TOWER STREET, HUDSON, MA 01749 U.S.A.
TEL: 617-562-3801 TWX: 710-347-0096
NEW YORK: 516-352-2341 LOS ANGELES: 213-388-8218

Circle 184 on Reader Service Card

The Complete Time Code System — and it's modular!

LTC Generator: 24, 25, 30 30DF, color-framing, jam-syncing (record source TC in U-bits, too), calendar.

LTC Reader: 1/20-100X, tach updating, user-selectable ATR lifter defeat TC sampling.

VITC Generator: SMPTE/EBU standards, selectable lines, broadcast quality insertion, jam-syncing.

VITC Reader: still-45X, selectable line searching.

Translator Interface: feeds VITC to video editors as LTC at all speeds (no mods needed) for both frame-accurate decision-making and editing, frees LTC audio track for stereo.

Character Inserter: selectable font, size, position, brightness, keyed/added, black/white characters.

Code Restorer: relocks, reshapes LTC for dubbing.

Serial Interface: studio computer/terminal communications, RS-232, SMPTE/RS-422 and teletypewriter.

Parallel Interface: for special purpose systems design.



Each module a complete product.
Buy only what you need.
Add modules as you grow.

Rep. inquiries cordially invited.

ADAMS-SMITH

34 TOWER STREET, HUDSON, MA 01749 U.S.A.
TEL: 617-562-3801 TWX: 710-347-0096
NEW YORK: 516-352-2341 • LOS ANGELES: 213-388-8218



Circle 185 on Reader Service Card

Manufacturers

PHASE TWO VIDEO

609 W. 50 St., New York, NY 10019
212 246-5940
Video post-production facility.

PHELPS DODGE COMMUNICATIONS CO.

Route 79, Marlboro, NJ 07746
201 462-1880

Rigid coaxial transmission lines & components; FM & communications antennas; directional couplers & harmonic filters.

See ad on pg. 159

PHILADELPHIA RESINS CORP.

20 Commerce Dr., Montgomeryville, PA 18936

215 855-8450

Electrically transparent antenna guys.

PHILIPS TELEVISION SYSTEMS

900 Corporate Dr., Mahwah, NJ 07430
201 529-1550

Studio, field & ENG/EFM cameras; one-inch C VTRs. Digital TBCs, noise reducers. NTSC monitors. UHF, VHF TV transmitters, TV exciters. Facility turnkey installations, mobile vehicle construction.

See ad on pg. 26

Field Offices:

CA 3760 Cahuenga Blvd. West,
N. Hollywood 91604 ... 213 766-8184
MD 801 Howard Grove Rd., David-
sonville 21035 ... 301 956-3065/6
MN 15611 Fish Point Rd.,
Prior Lake 55372 ... 612 447-6036
TX Route 2, 801 E. Woodglen,
Lewisville 75067 ... 817 455-2214

PHILIPS TEST & MEASURING INSTRUMENTS, INC.

85 McKee Dr., Mahwah, NJ 07430
201 529-3800

TV exciters; stereo generators, modulators; demodulators, RF & video test signal generators; automatic VITS analyzers; waveform monitors, vectorscopes, delayed sweep scopes, oscilloscopes & logic analyzers.

THE PHOEBUS CORP.

2800 Third St., San Francisco, CA 94107
415 550-0770

Lamps, quartz fixtures.

PINZONE COMM. PRODUCTS, INC.

10142 Fairmount Rd., Newbury, OH 44065
304 296-4493

Receive only & transmit/receive satellite earth stations, satellite receivers & STLs; status, alarm indicators.

PLASTIC REEL CORP. OF AMERICA

475 Boulevard, Elmwood Park, NJ 07407
201 796-6600

Empty audio & video reels, carts & containers; foam insert & rack configuration transportation cases; tape storage systems; equipment rental service.

POLARAD ELECTRONICS, INC.

5 Delaware Dr., Lake Success, NY 11042
516 328-1100

AM, FM & TV field intensity meters; tranceiver

Nobody will ever duplicate the Service!



...and it's the service behind the product that keeps the Amperex Plumbicon* out front.

No TV station or production facility can ever shut down while "waiting for parts". Plumbicon tubes are instantly available through your local distributors.

We learned to build smaller and smaller Plumbicon tubes that provide performance standards similar to the original; and we have learned to produce tubes with higher resolution and sensitivity, tubes with extended-red response, reduced comet-tailing and minimum lag. We developed and introduced Diode Gun™ tubes, low output capacitance tubes and tubes for very high resolution applications.

Aware of the TV camera users concern about the over-all operation of their cameras, (not merely about the characteristics of our tubes), we provide them with expert information, in print and via our field engineers. Written by and for TV professionals, we publish and distribute free, "Optical Perceptions", a series of applications bulletins devoted to the advance of video technology. Typical topics covered include camera/tube technology and operating/maintenance techniques.

Plumbicon users in need of immediate assistance or advice need only call us and we'll

have an expert there to help with the problem.

An emergency hotline is available 24 hours a day, 7 days a week, to provide instant response to your requirements. We also maintain a complete, modernly equipped, expertly staffed color TV studio and an applications lab in Slatersville to which Plumbicon customers are invited to send their camera for trouble-shooting.

Our warranty is not only designed for the customer's maximum benefit but whenever possible is interpreted in the customer's favor. For example, a customer may return any Plumbicon tube for testing (even a tube that is technically out of warranty) and we'll subject it

to a complete technical evaluation at our own expense and furnish the customer with a detailed engineering report on the tube.

In TV broadcasting, it's the service behind the product that keeps the product out front. That's why Amperex Plumbicon tubes still offer the best all-around package of performance, price and reliability available.

For more information, contact Amperex Electronic Corporation, Slatersville Division, Slatersville, Rhode Island 02876. Telephone: 401-762-3800.

Amperex®

... dedicated to product excellence

A NORTH AMERICAN PHILIPS COMPANY

*Registered trademark of N. V. Philips of the Netherlands

Manufacturers

test set; spectrum analyzers; RF signal generators.

POLAR RESEARCH, INC. ✓
Box 781, Thief River Falls, MN 56701
218 681-7413
Rotating VHF & UHF antenna mounts.

CONSTANTINE N. POLITES & CO.
833 Guenther Ave., Yeadon, PA 19050
215 626-4643
Hardware for lighting grids; tubes & clamps for tower construction.

POLYCOM TELEPRODUCTION
201 E. Erie St., Chicago, IL 60611
312 337-6000
Studio & mobile teleproduction facilities; video post-production facility.

PORTABLE ENERGY PRODUCTS INC. ✓
1875 S. Pearl St., Denver, CO 80210
303 778-8616
Nicaid & sealed lead-acid batteries & chargers.

PORTA-BRACE/K&H PRODUCTS ✓
Box 246, N. Bennington, VT 05257
802 442-9118
ENG equipment carts; recorder cases; ENG camera cases.
[See ad on pg. 129](#)

PORTA-PATTERN INC. ✓
Box 38945, 6822 Santa Monica Blvd., Los Angeles, CA 90038
213 461-3561
Optical test images, charts & slides.

THE POST GROUP ✓
6335 Homewood Ave., Los Angeles, CA 90028
213 462-2300
Video post-production facility.

POTOMAC INSTRUMENTS, INC. ✓
932 Philadelphia Ave., Silver Spring, MD 20910
301 589-2662
Antenna monitors; AM, FM & TV field intensity meters; RF test signal generators, phase meters; audio test signal generators; harmonic distortion, IM & wow & flutter meters; log printers, automatic radio monitors, alarm indicators.
[See ad on pg. 95](#)

POWER-OPTICS, INC. ✓
341 Main St., Collegeville, PA 19426
215 539-5300
Remote control systems; color monitor calibrators.

POWER PAK SYSTEMS, INC. ✓
Box 694, Cleburne, TX 76031
817 295-7771
Intercity microwave; microwave STLs; FM SCA equipment; program subcarrier equipment; FM translators.

PRACTICAL TECHNOLOGY ✓
12 Village Ctr., Box 449, Carmel Valley, CA 93924
408 659-3128
Logic analyzers.



PRECISION ECHO ✓
3105 Patrick Henry Dr., Santa Clara, Ca 95054
408 988-0516
Video animation controllers, compressor/positioners; video disc recorders.

PRIME TIME POST
6410 Santa Monica Blvd., Los Angeles, CA 90038
213 464-7151
Video post-production facility.

PROCART ✓
7012 27 St. W., Tacoma, WA 98466
206 565-4546
Audio tape cartridges.

PROCESSING PLUS ✓
1701 Union Blvd., Allentown, PA 18103
215 432-0067/800 523-9396
Audio processors; AM processors, AGCs, monitor amps, limiter/compressors.

PRODELIN, INC. ✓
Box 100, Claremont, NC 28610
800 438-9706
Satellite antennas; flexible transmission line; microwave antennas, reflectors & waveguides.

PRODUCERS COLOR SERVICE
24242 Northwestern Hwy., Southfield, MI 48075
313 352-5353
Studio & mobile teleproduction facilities; video post-production facility.

PRODUCERS VIDEO CENTER
Crown Center, 2450 Grand, Ste. 400, Kansas City, MO 64108
816 274-8335
Teleproduction & video post-production facilities.

PROFESSIONAL PRODUCTS, INC. ✓
4964 Fairmont Ave., Bethesda, MD 20814
301 657-2141
Engineering services & design; video system installations; equipment dealer.

PROFESSIONAL VIDEO SERVICES ✓
60 E. 42 St., New York, NY 10165
212 986-9886
Studio & mobile teleproduction facilities; video post-production facility; full service production company.

PROTECH AUDIO CORP. ✓
Flowerfield Bldg. 1, St. James, NY 11780
516 584-5855
ALC, AGC amps, AM compressor/limiters; hardwired intercoms; telco preamps, line & monitor amps, audio DAs, amp power supplies; slide attenuators; transformers; VCAs; automatic tone sensors.

PTS CORP.
5233 S. Hwy. 37, Bloomington, IN 47401
812 824-9331
Hum bucking coils; converter/amp rebuilding.

PYRAMID VIDEO, INC. ✓
National Press Building, Room 340, Washington, DC 20045
202 783-5030
TV production and transmission facilities.

QEI CORP. ✓
One Airport Dr., Box D, Williamstown, NJ 08094
609 728-2020
FM transmitters, exciters & SCA equipment; RF power amps; stereo generators; remote control equipment; modulation monitors; automatic transmission systems.

QSI SYSTEMS, INC. ✓
12 Linscott Rd., Box 2176, Woburn, MA 01888
617 938-1403
Character generators; source ID, countdown, video slate board & color bar generators; video DAs; demodulators; timers; 24-hour audio/video off-air loggers; engineering consultation.
[See ad on pg. 128](#)

Q-TV ✓
33 W. 60 St., New York, NY 10023
212 765-4200
Monitor-based, scroll, keyboard entry & ENG/EFP teleprompters.

QUAD-EIGHT ELECTRONICS ✓
11929 Vose St., N. Hollywood, CA 91605
213 764-1516
Mono, stereo, automated & audio for TV mixing consoles; digital audio editors; AM compressor/limiters, parametric & graphic equalizers; digital & analog reverb; preamps, line amps & LED meters.

QUANTA CORP. ✓
2440 S. Progress Dr., Salt Lake City, UT 84119
801 974-0992
Character generators, titlers; radio & TV newsroom computers; videotape evaluators.
[See ad on pg. 105](#)
Field Offices:
CA 3566 Sunnysdale Ct., San Jose 95117 408 985-8888
CT 57 North St., Ste. 122B, Danbury 06810 203 797-1179
GA 3566 Old Chamblee-Tucker Rd., #2, Atlanta 30340 404 493-3913
OH US Marketing & International Office, 16006 Waterloo Rd., Cleveland 44110 216 692-3410
OK 1535 South Memorial Dr., Ste. 124, Tulsa 74112 918 627-4151

QUANTUM AUDIO LABS ✓
1905 Riverside Dr., Glendale, CA 91201
213 841-0970
Mic mixers; portable, mono & stereo, & TV audio mixing consoles.

QUICK-SET, INC. ✓
3650 Woodhead Dr., Northbrook, IL 60062

Cost-Performance to Oki Doesn't Mean Less Performance for Lower Cost. Performance Takes Priority!



LT1210 Digital Television Standards Converter

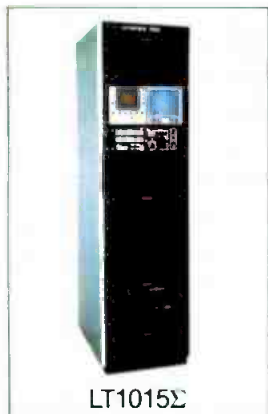
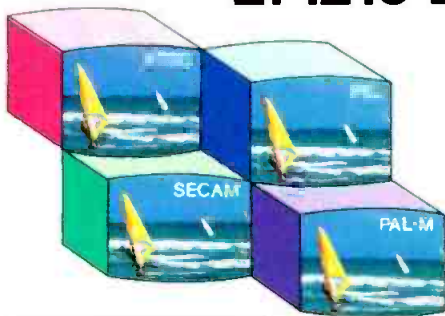

LT1015Σ

Professionals demand an uncommon level of picture quality in TV standards conversion. And production on the road requires a compact, reliable unit. Oki Electric built the LT1210 to deliver. It's the world's smallest converter able to handle NTSC, PAL, and SECAM, with PAL-M conversion as an option. Yet it incorporates every function and feature needed for producing studio-quality programming. The image enhancement function, for example, ensures a high-definition picture with outstanding image clarity. This converter is also a totally integral unit so no adaptor or changing of encoder/decoder modules is required for conversion between NTSC, PAL and SECAM.

The cost-performance of the LT1210 is nothing less than outstanding. Oki Electric's proven expertise in standards conversion combined with the latest in LSI technology results in a highly reliable, easy-to-use converter. The LT1210. Check it out. Anywhere.

Oki also produces the high-end LT1015Σ Digital TV Standards Converter.

In the U.S.A. and Canada, contact:

OKI Electric Overseas Corp.
One University Plaza,
Hackensack, New Jersey
07601 U.S.A.
Tel: 201-646-0011-0015
TWX: 7109905004 OKI ELEC HAK

In other areas, contact:

Head Office:
Overseas Marketing & Sales
10-3, Shibaura 4-chome,
Minato-ku, Tokyo 108, Japan
Tel: (03) 454-2111
Telex: J22627
Cable: OKIDENKI TOKYO

OKI
electric
industry
company, ltd.

Circle 187 on Reader Service Card

www.americanradiohistory.com

Manufacturers

312 498-0700

Tripods, heads, pedestals & dollies.

RACAL-DECCA CANADA, LTD. ✓

71 Selby Rd., Brampton, Ontario, Canada
L6W 1K5

416 457-8720

Lighting transformers; tower guy insulators;
base insulators.

RADIO ARTS, INC.

210 N. Pass Ave., Burbank, CA 91505

800 423-2840

Syndicated radio programming.

RADIOCOM ✓

335 E. 70 St., New York, NY 10021

212 794-9702

Radio business automation hardware.

RADIO SYSTEMS ✓

5131 W. Chester Pike, Edgemont, PA 19028

215 356-4700

Facility turnkey installations; acoustical construction; low power AM transmitters; pre-wired patchfields; studio furniture; power amps.

RADIOTECHNIQUES

402 Tenth Ave., Haddon Heights, NJ 08035

609 546-1841

Engineering consultation; earth station site selection.

RAINBO PRODUCTS ✓

404 N. River, Ypsilanti, MI 48197

313 482-6591

Lighting control products; remote-controlled color changer.

RAMKO RESEARCH ✓

11355 A Folsom Blvd., Rancho Cordova, CA 95670

916 635-3600

Mic mixers; portable, mono & stereo studio consoles; single, dual/triple-deck, phase control matrixing cart player/recorders; cassette player/recorders; replacement audio heads; audio carts, tape loaders; turntables, phono preamps; AM compressor/limiters; speakers; telco preamps, line, monitor & power amps, audio DAs, amp power supplies; LED meters & audio routers.

See ad on pg. 7

Refer to Reps/Distributors section

RAMSA (PANASONIC PROFESSIONAL AUDIO SYS.) ✓

1 Panasonic Way, Secaucus, NJ 07094

201 348-7470

Portable & mono & stereo studio consoles; monitor, power amps.

RANGERTONE RESEARCH, INC. ✓

509 Madison Ave., New York, NY 10022

212 753-5430

Sprocketed magnetic film transports; replacement audio heads, preamps & line

✓ MEANS IT'S VERIFIED

amps; VU meters; replacement video heads, VTR rebuilding service; 16/35 mm telecine projectors, optical multiplexers.

RANK PRECISION INDUSTRIES, INC. ✓

260 N. Route 303, W. Nyack, NY 10994

914 353-1914

16/35 mm, Super-8, slide flying spot telecine; 16/35 mm solid-state CCD telecine; telecine scene-by-scene color corrector; separate magnetic sound follower; TV frame store system.

RCA AMERICAN COMMUNICATIONS, INC. ✓

400 College Rd., Princeton, NJ 08540

609 734-4069

Satellite transmission services; post-production services.

RCA COMMERCIAL COMM. SYSTEMS DIV. ✓

Front & Cooper Sts., Camden, NJ 08102

609 338-3000

Studio, field, ENG/EFP & single-piece cameras. Quad & one-inch VTRs; video cart automation systems; replacement & rebuilt

SATT
Electronics

The SAM Mixers

RELIABLE REMOTE AUDIO

The SAM-82 and SAM-42 are probably the highest quality professional mixers in the world, built by a \$40 million company to military specs. Small, rugged and truly portable, over 800 SAMs are in use by demanding European broadcasters and studios. Ideal for video studios, mobile facilities and remote applications, options include an attractive desk-top console mount and direct channel outputs for CMX type operation. Price is about half of that famous Swiss and British pricing. (Please compare quality!)

Headquarters: (203) 775-6030 or (203) 775-4465
Los Angeles: (213) 468-0817 Bill VanDoren
Canada: (416) 868-0528 GERR Electro Acoustics Ltd.



Normally in Connecticut Stock
Rental and Leasing Available.

DIGITAL ENTERTAINMENT CORPORATION
P.O. BOX 95 • U.S. ROUTE 7 • BROOKFIELD • CONNECTICUT 06804
Circle 188 on Reader Service Card



heads & VTR rebuilding service; VTR slow-mo controllers; TBCs. Telecine cameras, 16/35 mm telecine projectors, optical multiplexers & telecine color correctors. Video editor/controllers & multisource editors. AM, FM, UHF & VHF transmitters; FM & TV exciters; FM & TV (HP & CP) antennas. Facility turnkey installations; mobile vehicle construction.

See ad on pgs. 38, 39

Refer to Reps/Distributors section
Field Offices:

- CA E. Mehaffey, Box 51924,
San Jose 95151 415 343-2741
- CA O.G. Bjerke, 4040 Vineland Ave.,
Ste. 204,
Studio City 91604 213 468-4083
- CN J. Watson, Suite 2300, North Tower,
Royal Bank Plaza,
Toronto, Ontario
M5J 2J4 416 865-7991
- CO J. Butts, Box 675,
Denver 80433 303 986-1521
- GA J. Kelly, 3395 Northeast Exy.,
Atlanta 30341 404 452-2340
- IN J. Ayers, 9240 N. Meridian St.,
Ste. 102,
Indianapolis 46260 ... 317 267-6395
- KS 8900 Indian Creek Parkway,
Ste. 410,
Overland Park 66210... 913 642-3185
- MN D. Schulte, 4601 Excelsior Blvd.,
Ste. 232,

- Minneapolis 55422..... 612 920-6395
- NJ R. Varda, 1099 Wall Street West,
Meadowlands Corp. Center,
Lyndhurst 07071 201 460-5580
- PA C. Koriwchak, 148 Brookdale Circle,
Pittsburgh 15317 412 941-5570
- RI P. Taylor, 18 Hope Ave.,
Warwick 02889 401 738-7722
- TX B. Laughlin, 17000 Dallas Parkway,
Ste. 102,
Dallas 75248 214 931-1683
- VA R. Dongelewicz, 1901 North Moore St.,
Arlington 22209 703 558-4233
- WA P. Lines, 1818 Westlake Ave. N.,
Ste. 222,
Seattle 98109 206 285-2375
- WI R. Yokes, 612 Port Washington Rd.,
Grafton 53024 414 377-8430

RCA D&SPD

2000 Clements Bridge Rd., Deptford, NJ
08096
609 853-2243

RF cable, connectors; vacuum tubes; solid state components; surge protectors.

RCA ELECTRO OPTICS & DEVICES

New Holland Ave., Lancaster, PA 17604

717 397-7661

Camera pickup tubes & RF power tubes; RF amps.

See ad on pg. 165

RCA SERVICE CO.

Broadcast Svces., 102 Gaither Dr., Mt.
Laurel, NJ 08054
609 778-0770

Field overhauls, repairs & service contracts on all RCA broadcast equipment; transmitter proofs & transmission line optimization.

RCA SOLID STATE DIV., TUBE OPS.

New Holland Ave., Lancaster, PA 17604
717 397-7661

Saticon imaging tubes; UHF, VHF, AM & FM transmission tubes.

R-COLUMBIA PRODUCTS CO., INC.

2008 St. Johns Ave., Highland Park, IL 60035
312 432-7915

Hardwired & RF intercoms; dynamic & electret/condenser mics.

REAL RADIO CO.

127 Glen Summer Rd., Pasadena, CA 91105
213 795-4900

Syndicated radio programming.

THE REAL WORLD TECHNOLOGIES GROUP, INC.



Sound quality.

200 Series On-Air Broadcast Control Console

The Audiotronics 200 Series represents the culmination of latest technology applied for broadcast use. Standard features include Penny & Giles linear VCA controlling faders for reliability and precise tracking accuracy even on stereo channels, noiseless hall effect/CMOS on/off switching, local power regulation on every module to prevent mass failure, built-in Control Room Monitoring controls, a comprehensive logic system and headphone amplifier with local equalization. Available in 4 mainframe sizes for up to 24 mono or stereo inputs, a full line of accessories is provided for custom tailoring to individual requirements.

Telephone Interface Accessory: Enables complete handling, processing and recording of telephone calls without compromising other console functions.

The 200 Series, the logical choice for on-air operations from music programming to newsrooms.

- Monitoring and Communications for Two Studios
- Equalizers
- Compressor/Limiter/Noise Gates
- Remote Controls
- Redundant Powering
- Clock & Timer



Model 218



audiotronics. inc.

3750 Old Getwell Rd.
Memphis, TN 38118 USA
Tel: (901) 362-1350
Telex: 533356

Circle 189 on Reader Service Card

Manufacturers

3176 Pullman St., Ste. 106, Costa Mesa, CA 92626

714 957-1061

VU & PPM video monitor displays; system & facilities consultation; engineering design & construction, fixed & mobile; product R&D, special projects.

RECORTEC, INC.

475 Ellis St., Mountain View, CA 94043
415 962-0220

Audio & video cassettes, tape cleaners & evaluators; U-type VCRs; videocassette automation systems; parallel interface machine control; videotape timers.

RE:DB CO., DIV. PIERCE INDUSTRIES

3120 E. Pico Blvd., Los Angeles, CA 90023
213 264-7855

Audio & video replacement & rebuilt tape heads.

REDDING RADIO, DIV. SJ INDUSTRIES

Box 344, Fairfield, CT 06430

Telco interface equipment; editing blades; mic call-letter plates.

REES ASSOC., INC.

4200 Perimeter Center Dr., Ste. 245, Oklahoma City, OK 73112
405 946-9800

Modular studio sets; facility turnkey installations; engineering consultation; studio & set design, financial services; earth station site selection; broadcast facility planning & design, complete architectural & engineering services.

REGISTER DATA SYSTEMS

Box 1246, Perry, GA 31069
912 987-2501

Business & traffic computer services & hardware.

RE INSTRUMENTS CORP.

31029 Center Ridge Rd., Westlake, OH 44145
216 871-7617

Signal multiplexers; stereo generators; fiberoptic transmission systems; modulation monitor, RF test signal generators, harmonic distortion & IM meters, spectrum analyzers, wow & flutter meters.

RE-PLAY VIDEO CARTRIDGE SERVICE

328 Meritt Ave., Pittsburgh, PA 15227
412 881-9172, 885-0959

Reloaded videocassettes.

RESEARCH TECHNOLOGY INT'L (RTI)

4700 Chase Ave., Lincolnwood, IL 60646
312 677-3000

Electronic film previewers & editors; hardware & software for film inventory & management; videotape cleaner/evaluators; tape & film timers; studio furniture & storage units; video cable, shipping cases.

RF TECHNOLOGY, INC.

145 Woodward Ave., S. Norwalk, CT 06854
203 866-4283

RF amplifiers; intercity, ENG, airborne & central receiver microwave systems; microwave STLs; microwave antennas.

RICHMOND SOUND DESIGN, LTD.

1234 W. 6 Ave., Vancouver, BC, Canada V6H 1A5
604 734-1217

Mic mixers; portable, mono & stereo & audio for TV mixing consoles; phono preamps; ALC & AGC amps; parametric & graphic equalizers; line, monitor & power amps, amp power supplies; audio post-production facility & recording studio.



RKO TAPE CORP.

3 Fairfield Crescent, West Caldwell, NJ 07006

201 575-8484

Open-reel audio tape & audio cassettes; tape duplicators; half-inch videotape.

RMS ELECTRONICS, INC.

50 Antin Pl., Bronx, NY 10462
212 892-6700

Dynamic mics; RF switches; video cable & connectors.

RODELCO ELECTRONICS CORP.

365A Comac Rd., Deer Park, NY 11729

516 643-5110

TV & FM translators.

ROH CORP.

3603 Clearview Pl. N.E., Atlanta, GA 30340
404 455-7940

Audio preamps; line & monitor amps & DAs; attenuators; intercom systems.

ROHDE & SCHWARZ SALES CO. (USA), INC.

13 Nevada Dr., Lake Success, NY 11040
516 488-7300

Demodulators; modulators, VHF-UHF transmitter; field intensity meters; video noise meters & test generators; VITS & VIR systems; group delay measuring systems; video distortion analyzers; TV data distortion meters.

See ad on pg. 67

ROSCO LABORATORIES, INC.

36 Bush Ave., Port Chester, NY 10573
914 937-1300

Lighting diffusion material, gels & filters; lens cleaning tissue; set design.

ROSCOR CORP.

6160 Oakton St., Morton Grove, IL 60053
312 966-3010

Video systems engineering & designing; mobile vehicle construction; video post-production facility.

ROSNER TELEVISION SYSTEMS, INC.

250 W. 57 St., New York, NY 10107
212 246-2850

Facility turnkey installations, engineering consultation & mobile vehicle construction.

ROSS VIDEO LTD.

9 Plaza Dr., Box 220, Iroquois, Ont., KOE 1K0 Canada

613 652-4889

Portable, studio & compact production switchers.

RPM-RADIO PROGRAMMING/MANAGEMENT

25140 Lahser Rd., Ste. 232, Southfield, MI 48034

800 521-2537

Syndicated radio programming.

RTS SYSTEMS, INC.

1100 W. Chestnut St., Burbank, CA 91506
213 843-7022

Hardwired intercoms & IFB systems; mic mixers & portable consoles; phono preamps; telco interface equipment; audio preamps, line, monitor & power amps; audio DAs, amp power supplies.

See ad on pg. 83

RUSLANG CORP.

320 Dewey St., Bridgeport, CT 06605
203 384-1266

Studio furniture, consoles & tape storage units; 19-inch equipment racks.

RUSSCO ELECTRONICS MFG., INC.

5690 E. Shields Ave., Fresno, CA 93727
209 291-5591

Audio DAs, preamps, power amps & audio consoles.

SACHTLER CORP. OF AMERICA

400 Oser Ave., Hauppauge, NY 11788
516 231-0033

Camera support systems; tripods, heads, ENG braces.

See ad on pg. 101

SADELCO, INC.

75 W. Forest Ave., Englewood, NJ 07631
201 569-3323

Calibrators, bridges & signal level meters for CATV.

SAKI MAGNETICS

8650 Hayden Pl., Culver City, CA 90230
213 559-6704

Audio & video replacement heads.

HOWARD W. SAMS & CO., INC.

4300 W. 62 St., Indianapolis, IN 46268
317 298-5400

Broadcast products directories.

SANSUI ELECTRONICS CORP.

1250 Valley Brook Ave., Lyndhurst, NJ 07071
201 460-9710

Audio cassette player/recorders; digital cassette recorders; graphic equalizers.

SATCOM TECHNOLOGIES

2912 Pacific Dr., Norcross, GA 30071
404 448-2116

Transmit/receive & receive only satellite earth stations, antennas.

SATELLELEASE

666 Dundee Rd., Ste. 1304, Northbrook, IL 60062

WHAT STANDS SEVEN INCHES HIGH, CONSUMES ONLY A PINCH OF POWER, COSTS LESS THAN \$30,000 AND IS THE PICTURE OF QUALITY?



Why, the revolutionary A42 video slide projector, of course.

A digital slide store doesn't have to be a bulky system loaded down with unnecessary features to justify a hefty price tag. We proved that to you at NAB '83 with our latest generation digital video slide storage system — the A42. This rack-mountable little beauty stands only 7 inches high! It combines the very latest in Winchester disk and digital video processing technology to deliver the highest quality images. And the price is right at \$29,900. We've got features galore,

including: on-line storage of 100 frames/200 fields (expandable to 300 frames/600 fields), automatic intermixing of field and frames, and an optional high-speed digital streaming tape drive for backup and off-line storage.

The A42. It's your opportunity to get full broadcast quality in the world's smallest slide store system. For details, call (415) 571-1711, or write to Abekas Video Systems, Inc., 319 Lincoln Centre Drive, Foster City, California 94404.

Abekas

Video Systems, Inc. 319 Lincoln Centre Drive, Foster City, California 94404

Manufacturers

312 272-7791

Transportable receive only earth station leasing.

SATELLITE BROADCAST NETWORK, INC./WEATHERMATION ✓

190 N. State St., Ste. 516, Chicago, IL 60601
312 263-6921
Weather radar systems & weather information services.

SATELLITE MUSIC NETWORK, INC. ✓

Box 31542, Dallas, TX 75231
214 343-9205
Radio programming.

SATT ELECTRONICS/DIGITAL ENTERTAINMENT CORP. ✓

Box 95, U.S. Rt. 7, Brookfield, CT 06804
203 775-4465
Portable audio consoles; mixer power supplies; connection cables.
See ad pg. 124

SAWYER CAMERA & INSTRUMENT CO.

6820 Santa Monica Blvd., Los Angeles, CA 90038
213 466-6111

Videotape, tape loaders, edit controllers & equipment rental service.

SCALA ELECTRONIC CORP. ✓

Box 4580, Medford, OR 97501
503 779-6500
Communications, STL, RPU, & LPTV antennas; CATV & TV/FM translator systems; power dividers; low noise preamps for UHF & VHF TV.

SCENE THREE, INC. ✓

1813 Eighth Ave. S., Nashville, TN 37203
615 385-2820
Studio & mobile teleproduction facilities; video post-production facility.

THE KEN SCHAFFER GROUP, INC. ✓

21 W. 58 St., New York, NY 10019
212 695-1107
Digital special effects, delay, reverb, time compression/expansion; RF intercoms & mics; FM transmitters; receive only & transportable satellite earth stations; slow scan transmitters; receivers; spectrum analyzers; equipment rental service, earth station site selection.

SCHARFF COMMUNICATIONS, INC. ✓

1600 Broadway, New York, NY 10019
212 582-7360

Audio equipment rentals; production communications, time code, noise reduction, effects, equalizers, recorders, microphones, PA, accessories.

SCHNEIDER CORP. OF AMERICA ✓

400 Crossways Park Dr., Woodbury, NY 11797
516 496-8500
ENG/EFP/studio/CCTV camera lenses & attachments.

SCIENTIFIC-ATLANTA, INC. ✓

3845 Pleasantdale Rd., Atlanta, GA 30340
404 441-4000
Satellite transmit/receive, receive only earth stations & STLs; power dividers, modulators; FM, TV & satellite antennas; foam dielectric transmission cable; demodulators; program subcarriers, frequency monitors; controllers & RF test signal generators; status, alarm indicators, equipment racks & RF cable.

SCIENTIFIC SYSTEMS, INC. ✓

92 Westwood Dr., Toms River, NJ 08753
201 255-2230
Audio DAs.

SCOTT INSTRUMENT LABORATORIES

13 Sagamore Park Rd., Hudson, NH 03051
603 880-6300
Sound level meters & analyzers.

OFF-AIR JITTERS?

Smooth them out with a QSI Demod 105

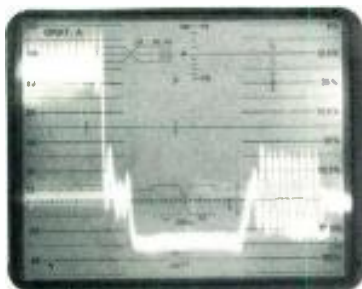
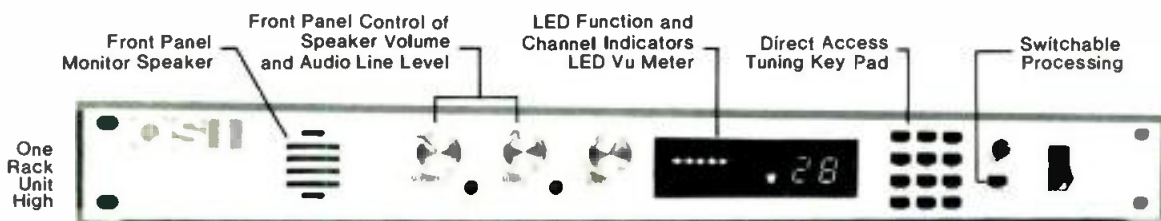

Video Output Unprocessed

Designed to meet the growing need for demodulated video with stable sync.

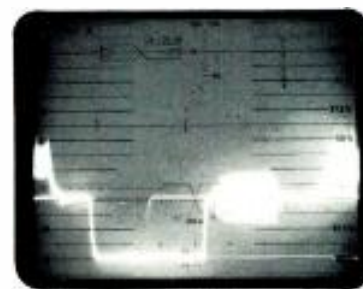

Video Output Processed



12 Linscott Road, P.O. Box 2176, WOBURN, MA 01888, (617) 938-1403

Circle 191 on Reader Service Card

HH SCOTT, INC.
20 Commerce Way, Woburn, MA 01888
617 933-8800
Audio cassette player/recorders; audio analyzers.

SCRIBE RECORDERS, INC. ✓
1618 Orrington, Evanston, IL 60201
312 328-5112
Portable ENG audio cassette recorder.

SEA-CAM, INC. ✓
6080 SW 28 St., Miami, FL 33155
305 665-5694
Underwater ENG/EFP camera housings.

SEACOR, INC.
123 Woodland Ave., Westwood, NJ 07675
201 666-5600
Capacitors.

SEEM DIGITAL ENTERTAINMENT CORP. ✓
Box 95, U.S. Rt. 7, Brookfield, CT 06804
203 775-4465
Subtitling system: mini-mixer.

SENCORE
3200 Sencore Dr., Sioux Falls, SD 57107
605 339-0100
Impedance bridges; audio & video test signal generators; oscilloscopes, multimeters & dB meters.

SENNHEISER ELEC. CORP. ✓
10 W. 37 St., New York, NY 10018
212 239-0190
Headphones; dynamic, electret/condenser. RF, shotgun, lavalier & modular mics; mic stands, booms & dollies; impedance bridges; mono studio consoles.

SESCOM, INC. ✓
1111 Las Vegas Blvd. N., Las Vegas, NV 89101
702 384-0993
Mic mixers, ALC & AGC amps; preamps, line, monitor & power amps, amp power supplies; rotary & slide attenuators; audio patch panels; transformers.

SETCOM CORP. ✓
1400 Stierlin Rd., Mountain View, CA 94043
415 965-8020
Headphones & hardwired intercoms.

SFENA CORP. ✓
26 17 Aviation Pkwy., Grand Prairie, TX 75051
800 527-1777
Camera & helicopter stabilizing systems.

SHALLCO, INC. ✓
Smithfield Industrial Park, Box 1089, Smithfield, NC 27577
919 934-3135
Rotary & slide attenuators.

✓ **MEANS IT'S VERIFIED**

SHAREPOINT SYSTEMS, INC.
402 Tenth Ave., Haddon Heights, NJ 08035
609 546-1841
Cart machine controller/timers, digital clocks & timers.

SHARP ELECTRONICS CORP. ✓
10 Sharp Plaza, Paramus, NJ 07652
201 265-5548
ENG/EFP, single tube & monochrome cameras; pro VHS VCR; NTSC color monitors. Audio cassette player/recorders & duplicators; disc playing equipment; speakers; preamps, line, monitor & power amps.
[See ad on pgs. 10, 11, 13](#)

Field Offices:
CA 20600 S. Alameda St.,
Carson 90810 213 637-9488
GA 6478 Interstate 85,
Norcross 30093 404 448-5230
PA P.O. Box 214,
Southampton 18966 ... 215 969-1115

SHINTRON CO., INC. ✓
144 Rogers St., Cambridge, MA 02138
617 491-8700
Audio DAs; character generators; compact

From Porta-Brace™, the...

Quiet Revolution



K and H Products, Ltd.
Box 246, North Bennington
Vermont 05257 (802) 442-9118

The **Video-Belt** shown on this Porta-Brace™ Recorder case may seem insignificant, but it actually has revolutionized the shoulder carrying of video recorders. Ask any professional who owns one or tried it at the NAB Show. It **gets the weight off your shoulder.**

Manufacturers

studio/mobile production switchers & encoded chromakeyers; SMPTE time code synchronizers, generators & readers; sync generators; pulse amps, video DAs & sc amps.

See ad on pg. 153

Refer to Reps/Distributors section

**SHIVELY LABS,
DIV. HOWELL LABS, INC.**
85 Harrison Rd., Bridgton, ME 04009
207 647-3327

RF filters, loads, switches; power dividers & diplexers; FM, TV (HP & CP) antennas; antenna monitors, RF power meters & wattmeters; RF cable & jackfields.

**SHOOK ELECTRONIC
ENTERPRISES, INC.**

6640 Topper Pky., San Antonio, TX 78233
512 653-6761

Mobile television production systems manufacturers; facility turnkey installations & studio design.

See ad on pg. 184

SHURE BROTHERS, INC.

222 Hartrey Ave., Evanston, IL 60204
312 866-2200

Mic mixers, portable consoles; pickup arms & phono cartridges; headphones; dynamic, electret/condenser, ribbon & lavalier mics, modular & capsule mics; mic stands &

booms; preamps, monitor, line & power amps; audio cable.

See ad on pg. 99

SIECOR/OPTICAL CABLE

610 Siecor Pk., Hickory, NC 28603
704 324-3801

Fiber optic transmission systems.

SIEGEL-ELECTRONICS

Box 33421, San Diego, CA 92103
619 295-4995

Post-production switchers; RGB decoders; title & non-additive keyers; sync & black burst generators; NTSC encoders, comb filter decoders, dropout compensators; color correctors; proc amps; image enhancers; image correction amplifiers.

SIEMENS CORP.

186 Wood Ave. S., Iselin, NJ 08830
201 321-3400

Gas-filled surge voltage protectors for cable amps & power supplies.

SIGMA ELECTRONICS, INC.

1830 State St., E. Petersburg, PA 17520
717 569-2681

Audio & video DAs; sync, black burst & color bar generators; sc, pulse & proc amps.

**SINGER BROADCAST
PRODUCTS**

90 Hopper St., Westbury, NY 11590
516 334-4210

AM, FM stereo generators; FM exciters; SCA generators.

SINGER EDUCATION SYSTEMS

See Telex

SITCO ANTENNAS

Box 20456, Portland, OR 97220
503 253-2000

UHF, VHF & LPTV receiving & transmitting antennas.

**SKAGGS
TELECOMMUNICATIONS
SERVICE (STS)**

Video Production Service, 5181 Amelia Earhart Dr., Box 27477, Salt Lake City, UT 84127

801 539-1427

Studio & mobile teleproduction facilities; post-production facility.

**SKIRPAN LIGHTING SYSTEMS,
INC.**

19030 72 Ave. S., Kent, WA 98032
206 251-5050

Automated lighting control systems.

✓ MEANS IT'S
VERIFIED

nautel

**TOTALLY
SOLID
STATE**

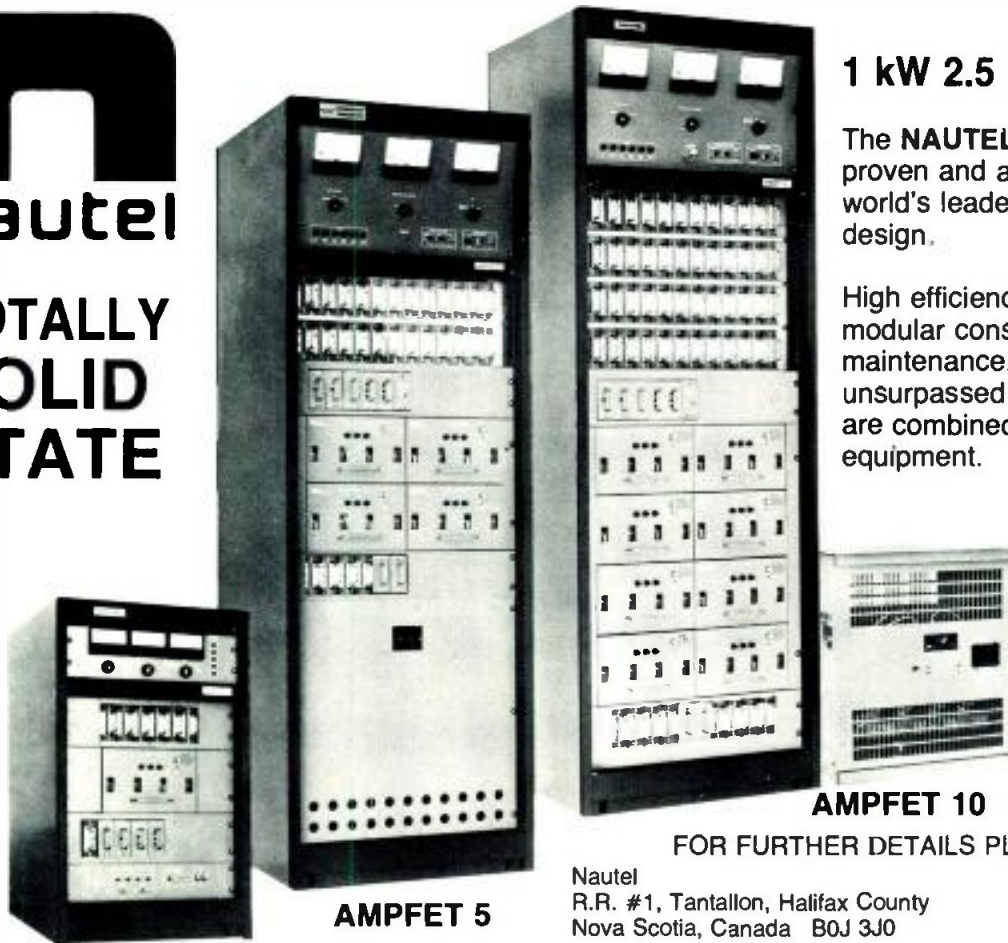

AMPFET 1

AMPFET 5

AMPFET 10

1 kW 2.5 kW 5 kW 10 kW AM

The **NAUTEL AMPFET** family is field proven and available NOW from the world's leader in solid state transmitter design.

High efficiency, cool operation, truly modular construction for ease of maintenance, together with unsurpassed performance specifications are combined in this **TOP VALUE** equipment.

Compare our specifications for both **MONO** and **AM STEREO** modes. Plug-in interface modules for all AM Stereo Exciters are available.

FOR FURTHER DETAILS PLEASE CONTACT

Nautel
R.R. #1, Tantallon, Halifax County
Nova Scotia, Canada B0J 3J0

Phone (902) 823-2233
Telex: 019-22552

Nautel Maine Inc.
201 Target Industrial Circle
Bangor, Maine 04401, U.S.A.

Phone (207) 947-8200
Telex: 944466

Circle 193 on Reader Service Card

SKOTEL CORP. ✓
1445 Provencher Blvd., Brossard, Que., J4W 1Z3 Canada
514 465-8990
Digital metronomes; SMPTE time code generators & readers.

SMITH-VICTOR CORP. ✓
301 N. Colfax, Griffith, IN 46319
219 924-6136
Audio cassettes, 1/2-inch videocassettes; tri-pods, heads; quartz lighting fixtures, lamps, stands, rigging & diffusion & effects material.

THE WARREN R. SMITH CO. ✓
Drawer C, Ocean Gate, NJ 08740
201 269-6795
Snorkel & telecine lenses; animatics stands, servo slide positioners & title positioners.

SNARR COMMUNICATIONS ✓
232 W. 800 South, Salt Lake City, UT 84101
801 532-7259
Downlink services for broadcast & communications.

SOLID ELECTRONICS LABS ✓
220 Brookthorpe Circle, Broomall, PA 19008
215 353-9449
Two-way communications equipment rental service.

SOLL, INC.
401 E. 74 St., New York, NY 10021
212 988-0290
Remote control systems; facility turnkey installations & engineering consultation.

SOLUTEC, LTD.
4360 Iberville St., Montreal, Que., Canada H2H 2L8
514 524-6893
Automated commercial inserters; impulse noise reducers; adaptive co-channel filters.

SONAR RADIO CORP. ✓
3000 Stirling Rd., Hollywood, FL 33021
305 981-8800
Audio & video tape bulk erasers; 2-way radio communications systems.

SONO-MAG CORP. (SMC) ✓
1833 W. Hovey Ave., Normal, IL 61761
309 452-5313
Computer automation controllers & complete automation systems; single, multiple, & time delay audio cart player/recorders.

SONY BROADCAST PRODUCTS CO. ✓
1 Sony Dr., Park Ridge, NJ 07656
201 930-1000
Studio, ENG/EFP, single-tube, three-tube & single-piece cameras; standalone micro-processor CCUs. One-inch C VTRs, U-type & pro Beta VCRs; slow motion VTR control-

lers; editor/controllers, multisource editors, SMPTE time code generator & readers; TBCs; monochrome & NTSC video monitors & projectors. Full line of videotape and cassettes.

See ad on pgs. 2-3

SONY, PRO AUDIO DIV. ✓
1 Sony Dr., Park Ridge, NJ 07656
201 930-1000

Portable audio consoles; digital reverb & signal processing systems; digital editing and mastering systems; fixed-head, multichannel digital audio recorders; headphones; dynamic, electret/condenser, lavalier, shotgun & RF mics, mic stands, booms & dollies; RF intercom systems.

See ad on pg. 174

Field Offices:

CA 700 W. Artesia Blvd.,
Compton 90220 213 537-4300
CA 1049 Elwell Ct.,
Palo Alto 94303 415 961-9060
CAN 1370 Sony Place,
Winnipeg, Manitoba,
R3C 3C3 204 284-7160
CAN 411 Gordon Baker Rd.,
Willowdale, Ontario,
M2H 2S6 416 499-5111
GA 2300 Peachford Rd.,
Atlanta 30338 404 451-7671
HI 1020 Auahi St.,
Honolulu 96814 808 537-9756
IL 500 Park Blvd.,
Itasca 60143 312 773-6000

Affordable Random Access Video Cart Systems

Cost effective, modular, and expandable



Component Switching and Processing

Modified 3/4" U-Matic Players with

Y-C/DOC outputs or 1/2" Type M with YIQ outputs are switched through our vertical interval Matrix

Switcher into a component TBC.



Automatic Directory Reading

Cassettes are loaded randomly into any empty deck. They rewind automatically to the head and the directory, containing a 4-digit reel ID number with precise start and finish times of each segment according to their location with reference to SMPTE time code is read into memory. The status indicating ID found and VTR location is displayed on the terminal.

Send for Brochure

Lake Systems Corporation,
55 Chapel Street, Newton,
MA 02160 617/244-6881

© Lake Systems Corp 1983

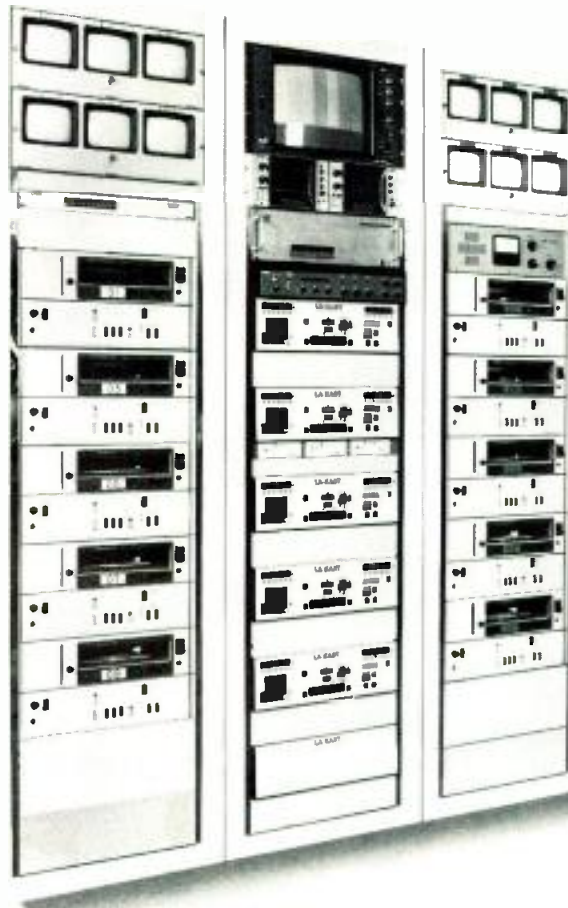
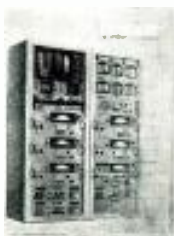

Any Tape Format

Choose from 1" Type C, 3/4" U-Matic, 1/2" Type M, or any combination.

1000 EVENTS

Or more with 68K Multi-Event Programmer and Disc Drive.

The computer identifies, searches out, and activates tape segments to be cued and aired in the order scheduled.

Lease Plans Available

LA-KART™
LAKE SYSTEMS CORPORATION

Prices Start at \$89,900

Circle 194 on Reader Service Card

Manufacturers

MD 9600 E. George Palmer Hwy.,
Lanham 20801 301 459-3676
MI 24301 Indoplex Cir., Farmington Hills
48018 313 477-4700
NJ 15 Essex Rd.,
Paramus 07652 201 368-5000
TX 1320 Walnut Hill,
Irving 75062 214 659-3677

SOPER SOUND MUSIC LIBRARY ✓
Box 498, Palo Alto, CA 94301
415 321-4022
Music library.

SOUNDCRAFT, INC. ✓
1517 20 St., Santa Monica, CA 90404
213 453-4591
Portable, studio, stereo & automated con-
soles; multitrack ATRs.

**SOUNDScriber MAGNETIC
RECORDING CO., INC.**
85 Willow St., New Haven, CT 06511
203 624-5179
Audio logging recorders.

SOUND TECHNOLOGY ✓
1400 Dell Ave., Campbell, CA 95008
408 378-6540
Audio & RF generators; harmonic distortion
& IM meters; autoranging tape recorder test
systems & test records; multitest systems;
spectrum analyzers, wow & flutter meters.
[See ad on pg. 161](#)

SOUND WORKSHOP ✓
1324 Motor Pkwy., Hauppauge, NY 11788
516 582-6210
TV audio consoles; audio/video production
consoles. Computer-based, SMPTE time
code-driven automation storage system.

SOUTH COAST VIDEO ✓
4500 Campus Dr., Newport Beach, CA
92660
714 556-1315
Teleproduction & video post-production fa-
cility.

SOUTHWEST TELEPRODUCTIONS
2649 Tarna Dr., Dallas, TX 75229
214 243-5719
Studio & mobile teleproduction facilities; vid-
eo post-production facility.

**SOUTHWESTERN
PROGRAMMING SERVICE** ✓
86 W. University Dr., Ste. 10, Mesa, AZ
85201
602 833-2224
Business automation software & custom
software service.

**SPECTRA COMPUTER
SYSTEMS, INC.** ✓
391 Chipeta Way, Ste. C, Salt Lake City, UT
84108
801 581-5478
Digital art/paint systems, weather symbol
inserters.

SPECTRA SONICS
3750 Airport Rd., Ogdens, UT 84403
801 392-7531
Mic mixers; portable, stereo & mono & TV au-

dio consoles; ALC & AGC amps, AM & FM
compressor/limiters, graphic equalizers &
analog special effects; speakers; preamps,
line, monitor & power amps, audio DAs &
amp power supplies. VU meters, audio test
signal generators & noise measurement; au-
dio cable.

SPECTRUM, INC.
1017 N. Minnesota Ave., Sioux Falls, SD
57104
605 339-3788
Radio business, scheduling, billing, traffic &
ledger automation hardware.

SPECTRUM PLANNING, INC. ✓
1850 N. Greenville, Ste. 122, Richardson, TX
75081
214 699-3536
Frequency coordination services for micro-
wave & satellite earth stations; group engi-
neering, cellular radio & paging.

SPHERE ELECTRONICS ✓
20201 A Prairie St., Chatsworth, CA 91311
213 349-4747
Portable, stereo & mono, automated & TV au-
dio consoles; preamps, line, monitor & pow-
er amps; audio patch panels.

SPIN PHYSICS, INC. ✓
3099 Science Park Rd., San Diego, CA
92121
619 453-5410
VTR replacement heads; quad head refur-
bishing.

SPINDLER & SAUPPE ✓
13034 Saticoy St., N. Hollywood, CA 91605
213 764-1800
Telecine slide projectors.

STAINLESS, INC. ✓
Third St., N. Wales, PA 19454
215 699-4871
Antenna towers.
[See ad on pg. 77](#)

STANCIL CORP. ✓
921 N. Highland Ave., Hollywood, CA 90038
213 464-7461
Tape-based loggers.

**STANDARD ELECTRIC TIME
CORP.** ✓
805 South Maumee St., Tecumseh, MI 49286
517 423-8331
Digital, master/slave clocks, timers & time
distribution.

**STANDARD TAPE LABORATORY,
INC.**
26120 Eden Landing Rd., #5, Hayward, CA
94545
415 786-3546
Audio test tapes; magnetic test film.

STANTON MAGNETICS, INC. ✓
200 Terminal Dr., Plainview, NY 11803
212 445-0063

Phono cartridges, phono preamps, record
cleaning & care; headphones.

**STANTRON, DIV. WYCO METAL
PRODS.**
6900-6918 Beck Ave., N. Hollywood, CA
91605
213 875-0800
Studio furniture, consoles & 19-inch equip-
ment racks.
[See ad on pg. 174](#)

STAR CASE MFG. CO., INC. ✓
15525 S. 70 Ct., Orland Park, IL 60462
312 429-6200
Foam insert & rack mounting transportation
cases; production & post-production con-
soles.

STARFAX, INC.
8157 Lankershim Blvd., N. Hollywood, CA
91605
213 768-2905
Mobile & post-production facilities.

STATION BUSINESS SYSTEMS
See Magnicom

STEPHENS ELECTRONICS, INC. ✓
3513 Pacific Ave., Burbank, CA 91505
213 842-5116
Open-reel, portable, studio & multitrack
ATRs; splicing blocks, tape; SMPTE time
code synchronizers.

STOREEL CORP. ✓
2050-C Carroll Ave., Ste. #2, Box 80523,
Atlanta, GA 30341
404 458-3280
Tape storage units.
[See ad on pg. 112](#)

STRAIGHT WIRE AUDIO, INC. ✓
2523 Wilson Blvd., Arlington, VA 22201
703 522-7780
Noise reduction; phono preamps; preamps,
line, monitor & power amps, audio DAs,
modular enclosures & amp power supplies.

STRAND CENTURY ✓
20 Bushes Ln., Elmwood Park, NJ 07407
201 791-7000
Cyc lighting; HMI, CSI & quartz fixtures;
stands & rigging; lighting control systems &
dimmer packs.

**STUDER REVOK
AMERICA, INC.** ✓
1425 Elm Hill Pike, Nashville, TN 37210
615 254-5651
Mic mixers; portable, mono & stereo & TV au-
dio consoles; portable, studio & multitrack
ATRs & cassette player/recorders; SMPTE
time code synchronizers; turntables; speak-
ers; line, telco monitor & power amps; PPM
level indicators; mobile vehicle construction;
facility turnkey installations.
[See ad on pg. 117](#)

Refer to Reps/Distributors section
Field Offices:
CA 954 Hawthorne Dr.,
Walnut Creek 94596 . . . 415 930-9866
CA 14066 Burbank Blvd.,
Van Nuys 01401 213 780-4234



For those who think they've heard it all...

Neve's full line of broadcast audio consoles

If you've heard it all, chances are you use or own a Neve. If you *think* you've heard it all, we'd like to take you beyond your sound barrier with one of Neve's full line of audio consoles and post-production systems.

We think you should hear for yourself what so many audio engineers and broadcast facility personnel already know: For superior technical performance, reliability, logic circuitry (that can interface with switchers, mic muting, loudspeaker muting, etc.), exceptional value, maintenance-ease and a pure, natural sound, there's nothing that comes close to Neve.

Of course, since many broadcasters already know about

Neve's quality, they've chosen to invest in a Neve. Networks and independent stations invest in Neve to ensure that their audience hears the finest sound available. Post-production facilities invest in Neve to ensure that their clients receive the finest product available and to keep clients coming back, while attracting new business with the Neve name.

Neve designs a full line of audio consoles and probably has a system to fit your specific needs.

So unless you've heard it all, isn't it time to aspire to Neve?

For further information, call us, or write.

Aspire to Neve

RUPERT NEVE INCORPORATED: Berkshire Industrial Park, Bethel, Connecticut 06801 (203) 744-6230 Telex 969638 • 7533 Sunset Blvd., Hollywood, California 90046 (213) 874-8124 Telex 194942 • RUPERT NEVE OF CANADA, LTD. represented by: Manta Electronics Group, 204 King St. East, Toronto, Ontario M5A 1J7 Canada (416) 868-0513 Telex 06-986766 • Sonotechnique, 2585 Bates, Suite 304, Montreal, P.Q. H3S 1A9 Canada (514) 739-3368 Telex 055-62171
NEVE ELECTRONICS INTERNATIONAL, LTD.: Cambridge House, Melbourn, Royston, Hertfordshire, SG8 6AU England Phone (0763) 60776
RUPERT NEVE GmbH: 6100 Darmstadt Bismarckstrasse 114, West Germany Phone (06151) 81764.

Circle 195 on Reader Service Card

www.americanradiohistory.com

Manufacturers

IL Brian Tucker, 11 S. Dr.,
Tower Lake,
Barrington 60010 312 526-1660
NY 155 Ave. of the Americas,
New York 10013 212 255-4462
TX 831 Woodlawn Ave.,
Dallas 75208 214 943-2239

STUDIO FILM & TAPE, INC. ✓
6670 Santa Monica Blvd., Hollywood, CA
90038
213 466-8101
Videotape & film.



STUDIOMASTER, INC.
1365-C Dynamics St., Anaheim, CA 92806
714 528-4930
Mic mixers; portable, stereo & mono & TV audio
consoles; cassette player/recorders;
monitor & power amps.

**JOHN M. SULLIVAN
ASSOC., INC.** ✓
880 Commonwealth Ave., Boston, MA 02215
617 227-1710
Equipment, stage & studio rental service;
mobile teleproduction facility; audio & video
post-production facility.

SUNDANCE PRODUCTIONS, INC.
7141 Envoy Ct., Dallas, TX 75247
214 688-0081
Studio & mobile teleproduction facilities; vid-
eo post-production facility.

SUNRISE CANYON VIDEO
439 Western Ave., Glendale, CA 91201
213 241-5173
Studio & mobile teleproduction facilities; vid-
eo post-production facility.

SUPERSCOPE, INC. ✓
20525 Northoff, Chatsworth, CA 91311
213 998-9333
Electret/condenser mics; portable cassette
recorders.

THE SUPERIOR ELECTRIC CO. ✓
383 Middle St., Bristol, CT 06010
203 582-9561
Lighting dimmers; automatic voltage regula-
tors; cable connectors; surge protectors;
transformers.

SUPEREX ELECTRONICS
151 Ludlow St., Yonkers, NY 10705
914 965-6906
Parametric equalizers; headphones; bulk
erasers; video filters, signal & cable equal-
izers; image enhancers & video multi-
processors; video DAs.

SURCOM ASSOCIATES, INC. ✓
305 Wisconsin Ave., Oceanside, CA 92054
619 722-6162
Transmitting capacitors; RF components.
[See ad on pg. 166](#)

SWAGER TOWER CORP.
Box 656, Fremont, IN 46737
219 495-5165
Tower masts, hardware & lighting.

SWINTEK ENTERPRISES, INC. ✓
1180 Aster Ave. #J, Sunnyvale, CA 94086
408 249-5594
Intercoms; RF & lavalier mics; two-way radio
transmitters/receivers.

SWITCHCRAFT, INC. ✓
5555 N. Elston Ave., Chicago, IL 60630
312 792-2700
Audio cable, connectors & jackfields.

SWR, INC. ✓
Box 215, Goffstown, NH 03045
603 497-3000
Rigid transmission line & accessories; RF ca-
ble & connectors; UHF & VHF antennas; RF
switches.

SYMETRIX, INC. ✓
109 Bell Street, Seattle, WA 98121
206 624-5012
AM & FM compressor/limiters, parametric
equalizers; telco interface equipment; moni-
tor & power amps; audio patch panels.

**SYRACUSE SCENERY & STAGE
LIGHTING, INC.** ✓
1423 N. Salina St., Syracuse, NY 13208
315 474-2474
Lighting grids; scenery rigging.

SYSTEM ASSOCIATES ✓
5801 Uplander Way, Culver City, CA 90230
213 641-2042
Used broadcast equipment broker & listing
catalog.

SYSTRON DONNER ✓
2727 Systron Dr., Concord, CA 94518
415 682-6161
Digital clocks, time distribution systems; fre-
quency monitors & counters; RF generators;
multimeters, dB meters; multitest systems;
microwave equipment.

**TABER MANUFACTURING &
ENGINEERING CO.** ✓
2081 Edison Ave., San Leandro, CA 94577
415 635-3831
Audio replacement heads for VTRs & ATRs;
audio & video bulk erasers; VTR replace-
ment heads & refurbishing; general recorder
service & parts; audio preamps, line amps &
amp power supplies; new videotape; reels.

TAMRON INDUSTRIES ✓
24 Valley Rd., Port Washington, NY 11050
800 645-3368/212 523-8989
Video camera lenses.

TANDBERG OF AMERICA, INC. ✓
Labriola Ct., Armonk, NY 10504
914 273-9150
Open reel & cassette recorder/players; FM
monitor tuners, audio monitors; preamps &
power amps; receivers.
[See ad on pg. 144](#)

WILLIAM B. TANNER CO. ✓
2714 Union Ext., Memphis, TN 38112
901 320-4212
Music library; radio & TV audio production.

TAPEPOWER ✓
304 E. 45 St., New York, NY 10017
212 370-9191
Studio & mobile teleproduction facilities; vid-
eo post-production facility.

TAPEX CORP.
228 Fifth St., Ste. 2, Box 65668, W. Des
Moines, IA 50265
515 274-3087
Audio carts, cassettes & test tapes.

**TBS FIELD OPERATIONS, DIV. ✓
TURNER BDCST.**
1050 Techwood Dr., Atlanta, GA 30318
404 898-8736
Mobile video production facilities.

TDK ELECTRONICS CORP. ✓
12 Harbor Park Dr., Port Washington, NY
11050
516 625-0100
Audio & video cassettes, open reel, bulk &
test tape; tape cleaners/evaluators.

TEAC CORP. OF AMERICA ✓
7733 Telegraph Rd., Montebello, CA 90640
213 726-0303
Stereo studio consoles; open-reel ATRs;
cassette decks, head degaussers; audio
preamps, amp power supplies; graphic
equalizers & filters; dynamic & electret/
condenser mics.

TEATRONICS, INC.
101-D Suburban Rd., San Luis Obispo, CA
93401
805 544-3555
Lighting control boards, dimmer packs.

TECH ELECTRONICS, INC.
6000 Peachtree Rd., NE, Atlanta, GA 30341
404 455-7626
Programmable videotape controllers; cus-
tom remote control for a/v systems.

TECH LABORATORIES, INC.
Bergen & Edsall Blvds., Palisades Pk., NJ
07650
201 944-2221
Rotary & slide attenuators.

TECHNISPHERE CORP. ✓
215 E. 27 St., New York, NY 10016
212 889-9170
Equipment sales, rental, & service; post-
production facility; electronics design & re-
pair services; facility installation & design.

TECHNICS ✓
One Panasonic Way, Secaucus, NJ 07094
201 348-7783
Turntables; direct drive tape decks & cas-
sette players.

TECHNOLOGY SERVICE CORP. ✓
2950 31 St., Santa Monica, CA 90405
213 450-9755
Weather radar systems.

Ampex 197: designed especially for broadcast.

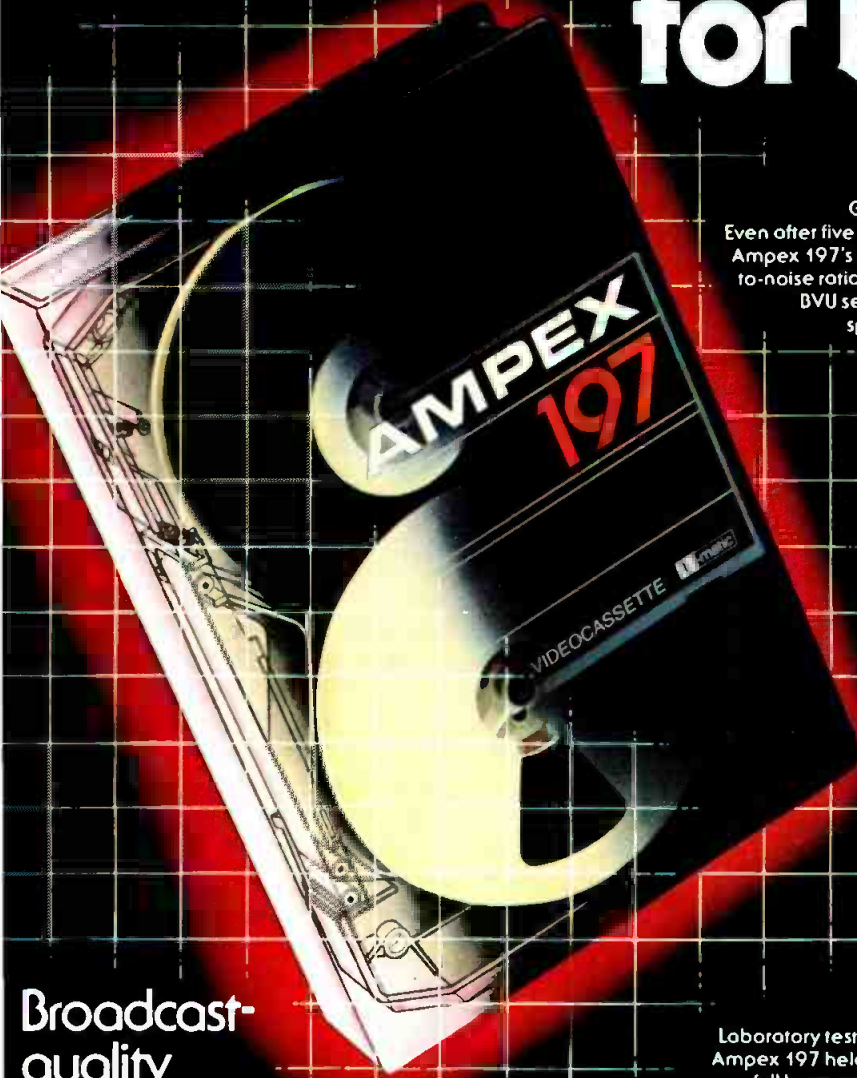

**AUDIO
MULTIPLE
GENERATIONS**
Even after five generations,
Ampex 197's audio signal-
to-noise ratio exceeds the
BVU series machine
specifications.

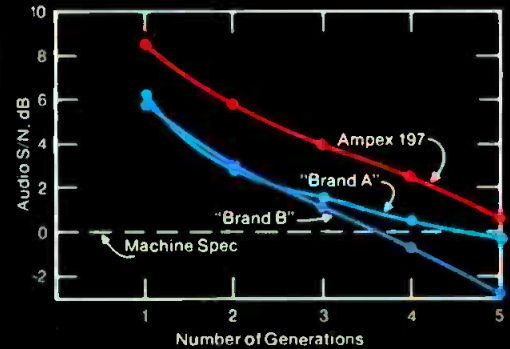

Broadcast-quality sound.

Ampex 197 offers superior signal-to-noise and low distortion characteristics. This means crisper, cleaner audio performance under heavy editing conditions and multiple generation dubbing. Plus excellent stereo fidelity when used for music recording.

Broadcast-quality color and sharpness.

The Ampex 197 3/4" videocassette was developed with nothing less than perfection as the goal.

With superb chrominance and luminance performance it is ideal for ENG, EFP and on-line editing.

Ampex 197 has been especially formulated to optimize the performance of Sony BVU recorders.

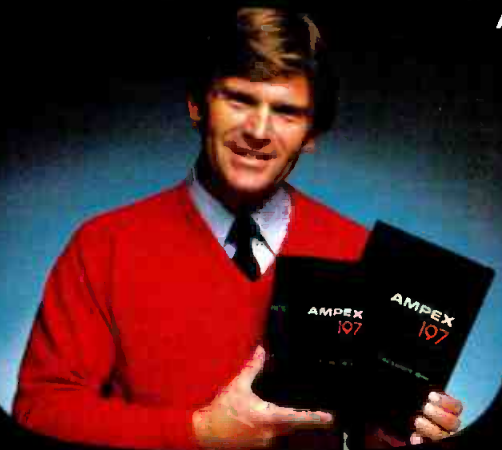

**STILL
FRAME
DURABILITY**

Laboratory tests proved that Ampex 197 held up for three full hours with no RF loss.



Broadcast-quality reliability.

In blind field testing, Ampex 197 got the highest marks from broadcast professionals for picture quality, stability, and durability.

Find out more about why Ampex 197 is quality worth broadcasting. Call your Ampex Regional Office or write to: Ampex Corporation, 401 Broadway, Redwood City, CA 94063 (415) 367-3809

AMPEX

Ampex Corporation • One of The Signal Companies

Quality worth broadcasting.

Manufacturers

TECHTRAN INTERNATIONAL, INC. ✓

Box 2245, Appleton, WI 54913
414 731-8679
Portable VCR packages.

TEKTRONIX, INC. ✓

Box 500, Beaverton, OR 97007
503 627-2229/800 547-8708

Sync, black burst, color bar, multiburst, source identifiers; staircase ramp generators; frame synchronizers; NTSC & RGB monitors, monitor calibrators; demodulators; harmonic distortion meters, spectrum & sideband analyzers; RF & video test signal generators, automatic VITS analyzers; waveform monitors, vectorscopes, oscilloscopes, delayed sweep scopes, multimeters & logic analyzers; fiber optic transmission; automatic TV monitors.

TELCOM RESEARCH ✓

1163 King Rd., Burlington, Ont., Canada
416 681-2450
Time code equipment.

TELEASE ✓

1875 Century Park East, Suite 930, Los Angeles, CA 90067
213 552-1055
Design and manufacture of addressable secure TV, encoding & decoding systems; modulators.

TELE-CINE CORP., DIV. SCHNEIDER CORP. OF AMERICA ✓

400 Crossways Park Dr., Woodbury, NY 11797
516 496-8500
Video camera lenses, lens extender & filters; equipment rental service.
See ad on pg. 116

TELE-COLOR PRODUCTIONS, INC. (TCP) ✓

150 S. Gordon St., Alexandria, VA 22304
703 823-2800
Studio & mobile teleproduction facilities; video post-production facility.

TELECTRO SYSTEMS CORP. ✓

96-18 43 Ave., Corona, NY 11368
212 651-8900
Single & multiple audio cart player/recorders; tape duplicators; speakers.

TELEDYNE BIG BEAM ✓

Box 518, 290 E. Prairie, Crystal Lake, IL 60014
815 459-6100
Emergency lighting systems.

TELEDYNE CAMERA SYSTEMS ✓

131 N. Fifth Ave., Arcadia, CA 91006
213 359-6691
Solid state cameras; video-to-16/35 mm film transfer systems.



TELEDYNE ENERGY SYSTEMS ✓

110 W. Timonium Rd., Timonium, MD 21093
301 252-8220
Power generators.

TELE-IMAGE, INC. ✓

5630 Beverly Hill, Houston, TX 77057
713 977-2635
Studio & mobile teleproduction facilities; video post-production facility.

TELE-IMAGE, INC. ✓

2225 Beltline Rd., Ste. 321, Carrollton, TX 75006
214 245-3561
Studio & mobile teleproduction facilities; video post-production facility.

TELEMATION PRODUCTIONS, INC./PHOENIX ✓

834 N. 7 Ave., Phoenix, AZ 85007
602 254-1600
Studio & mobile teleproduction facilities; video post-production facility.

TELEMATION PRODUCTIONS, INC./SEATTLE ✓

1200 Stewart St., Seattle, WA 98112
206 623-5934
Studio & mobile teleproduction facilities; video post-production facility.

TELEMATION PRODUCTIONS, INC. ✓

7700 East Iliff, Denver, CO 80231
303 751-6000
Studio & mobile teleproduction facilities; video post-production facility.

TELE-MEASUREMENTS, INC. ✓

145 Main Ave., Clifton, NJ 07014
201 473-8822/800 223-0052
Facility turnkey installations; engineering consultants; mobile vehicle construction; studio design.

TELEMET, DIV. GEOTEL, INC. ✓

185 Dixon Ave., Amityville, NY 11701
516 842-2300
RGB & encoded chromakeyers; parallel & serial interface routing switchers; sync, color bar, multiburst & staircase ramp generators; comb filter decoders; pulse amps & video DAs; modulators; telco & fiberoptic STLs; demodulators; video test signal generators. Audio DAs; monitor & power amps; VU meters.
See ad on pg. 172
Refer to Reps/Distributors section

TELEPROMPTER PRODUCTIONS ✓

5120 Broadway, New York, NY 10034
212 942-7200
Studio & mobile teleproduction facilities; video post-production facility.

TELESCRIPT, INC. ✓

445 Livingston St., Norwood, NJ 07647
201 767-6733
Prompting systems.



Fidelipackage

One-Stop Shopping For:

- Mobile, Wall Mount or Table Top Cart Racks
- On-Air Light (English, Spanish or as required)
- Blank-IT Tape Eraser
- Gold Standard Test Tapes
- Guide Height Gage
- Right-angle Zenith Gage
- Head Insertion Gage
- HOT Tape Cartridge Tape Splicing Tape
- Splicing/Editing Block
- Delay Cartridges
- Cartridge Labels
- Wow & Flutter Meter

Write today for additional information. Or call your Fidelipac Distributor or



FIDELIPAC®
BROADCAST TAPE PRODUCTS

Fidelipac Corporation
P.O. Box 808 • Moorestown, NJ 08057 • U.S.A.
609-235-3900 TELEX 710-897-0254
Toll Free 800-HOT TAPE

® Trademark

Circle 197 on Reader Service Card

At Digital Video, one great idea automatically leads to another . . .

- Maintains lock through 40 x normal speed in forward and reverse
- Color lock through 10 times play
- Velocity compensation
- Full frame memory
- Auto color framing
- RS 170A output
- Switch selectable test signal generator
- Direct feed or heterodyne color modes
- Digital Proc Amp
- Hot-switch between non-synchronous sources
- Automatic fault detection and concealment
- Passes VITS, VIRS, closed captions and teletext
- Optional remote control

First, there was the pioneering DPS-103. The industry's first single clock TBC is already a best seller.

Now, taking the next logical step in developing this unique product philosophy, Digital Video introduces the DPS-106 Component TBC/Framestore. The same "picture perfect" features as the DPS-103, plus the versatility of a full framestore.

The DPS-106 simultaneously corrects time base and blanking errors. It has freeze field/frame and field select. And it will synchronize remote heterodyne feeds.

All this makes it a great idea for 1/2 and 3/4" editing. For electronic field production, viewing and pre-production.

But, possibly the greatest idea of all is the price. Only \$10,950.

To find out how our great idea will help to give you ideas, call Digital Video Systems, or your local dealer.

Digital Video Systems Corp.
A subsidiary of
Scientific-Atlanta, Inc.

Toronto (416) 499-4826
Or toll free, (800) 828-7644
In New York (800) 462-1134



Manufacturers

TELESOURCE COMMUNICATIONS ✓
Box 7132, Phoenix, AZ 85011
602 265-1232
Services for automated newsrooms.

TELETRONICS ✓
231 E. 55 St., New York, NY 10022
212 355-1600
Studio & mobile teleproduction facilities; video post-production facility.

TELEVISION ASSOCIATES, INC. ✓
2410 Charleston Rd., Mountain View, CA 94043
415 967-6040
Studio & mobile teleproduction facilities; video post-production facility.

TELEVISION ENGINEERING CORP. ✓
580 Goddard Ave., Chesterfield, MO 63017
314 532-4700
Facility turnkey supply & installation; mobile van construction; TV studio design.

TELEVISION EQUIPMENT ASSOCIATES (TEA) ✓
Box 393, S. Salem, NY 10590
914 763-8893
Racal headphones & intercoms with dynamic, electret/condenser mics; Link audio & video DAs; Elcon videotape cleaner/evaluator; Mathey video filters & delay lines; video DAs; video color monitor calibrators; teletext; VG Electronics zone plate generators.

TELEVISION TECHNOLOGY CORP. ✓
5970 W. 60 Ave., Arvada, CO 80003
303 423-1652
UHF, VHF, & LPTV transmitters & translators; RF amps, power dividers & modulators.

TELEX COMMUNICATIONS, INC. ✓
9600 Aldrich Ave. S., Minneapolis, MN 55420
612 884-4051
Cart player/recorders; 2,4-track studio ATRs; tape duplicators, tape-based loggers; test tapes; headphones, hardwired intercoms; dynamic, electret/condenser & lavaliere mics; preamps; communication antennas; towers & masts, hardware & construction equipment. 16/35 mm telecine & slide projectors.
[See ad on pgs. 41, 85](#)

TELFAX COMMUNICATIONS
Box 31, Webster City, IA 50595
515 832-1263
Mic mixers, portable consoles; telco interface equipment; line amps.

TELONIC/BERKELEY
Box 277, Laguna Beach, CA 92652
714 494-9401
RF attenuators; sweep generators; RF filters; impedance bridges; dB meters; microwave systems.

TEMTRON ELECTRONICS, LTD.
15 Main St., East Rockaway, NY 11518
516 599-6400

Camera tubes; transmitter tubes; quartz-halogen lamps.

TENNAPLEX SYSTEMS LTD. ✓
34 Bentley Ave., Ottawa, Ont., K2E 6T8
Canada
613 226-5870
RF switches, filters & diplexers; FM, TV (HP & CP) & communication antennas.

TENDEL CORP. ✓
1506 Dell Ave., Campbell, CA 95008
408 379-1881
Audio & video tape alignment & tension gauges; spindle height gauges; video head protrusion gauges.

TEPCO CORP.
Box 680, Rapid City, SD 57709
605 343-7200
LPTV transmitters & translators; RF filters; modulators; subcarrier equipment.

TERRACOM, DIV. LORAL CORP. ✓
9020 Balboa Ave., San Diego, CA 92123
714 278-4100
Microwave STLs; portable & mobile ENG microwave systems; digital microwave systems for audio & slowscan video; digital audio channel multiplexers.

TEXAS ELECTRONICS, INC. ✓
Box 7225, Dallas, TX 75209
214 631-2490
Weather information & equipment services.

TEXSCAN CORP. ✓
2960 Grand Ave., Phoenix, AZ 85017
602 252-5021
Impedance bridges; spectrum analyzers; oscilloscopes; character generators, draw-on-screen graphics systems; RF amps, attenuators, filters.

TEXWIPE ✓
650 Crescent Ave., Upper Saddle River, NJ 07458
201 327-5577
Audio & video head cleaners.

TFT, INC. ✓
3090 Oakmead Village Dr., Santa Clara, CA 95051
408 727-7272
EBS two-tone systems; remote control systems; microwave STLs; FM & TV SCA equipment; demodulators, modulation & frequency monitors; status alarm indicators; AM addressable receivers.
[See ad on pgs. 16, 140, 141](#)
Refer to Reps/Distributors section

THALNER ELECTRONIC LABORATORIES ✓
7235 Jackson Rd., Ann Arbor, MI 48103
313 761-4506
Character generators; countdown generators; counters; timers; screen splitters & time/date generators.

THEATRE SERVICE & SUPPLY CORP. ✓
1792 Union Ave., Baltimore, MD 21211
301 467-1225
Studio lighting, cycs, support equipment.

THEATRE TECHNIQUES, INC. ✓
60 Connolly Pkwy, Hamden, CT 06514
203 281-6111
Hardwired intercoms; manual & automatic light dimmer controls; patch panels.

THEATRICAL SERVICES, INC.
128 S. Washington, Wichita, KS 67202
316 263-4415
Lighting control boards & dimmer packs, diffusion & efx materials, lighting fixtures.

THERMODYNE INTL., LTD. ✓
20850 S. Alameda St., Long Beach, CA 90810
213 603-1976
Foam insert and rack configuration equipment transportation cases.

THIRD COAST VIDEO, INC. ✓
501 North I. H. 35, Austin, TX 78702
512 473-2020
Studio & mobile teleproduction facilities; video post-production facility.

THOMSON-CSF BROADCAST, INC. ✓
37 Brownhouse Rd., Stamford, CT 06902
203 965-7000
ALC & AGC amps, AM & FM compressor/limiters; presence equalizers; audio DAs. Studio, lightweight, ENG & field cameras; recorder/cameras; character generators, digital art/paint systems, framestores, bit pad digitizers & weather symbol inserters; title, downstream & non-additive keyers; TBCs, field & frame synchronizers, TBC framestores, noise reducers, image enhancers, color correctors, chroma keyers & video multiplexers; graphics composing services; LPTV transmitters.
[See ad on Cover 3](#)
Field Offices:
CA Mike Clayton, 1919 W. Magnolia Blvd., Burbank 91506 213 849-2188
FL Marty McGreevy, 5778 Grand Lagoon Blvd., Pensacola 35207 904 492-2870
GA Frank Benson, 107 Tuliptree Terrace, Peachtree City 30269 . . 404 487-6756
IL Tom Lorenzen, 18474 W. Rae Lane, Gurnee 60031 312 356-5575
TX Marty McGreevy, Houston 713 933-1700
VA Al Audick, 8005 Karl Rd., Alexandria 22308 202 296-9189

THOMSON-CSF COMPONENTS CORP. ✓
301 N. 17, Rutherford, NJ 07070
201 438-2300
Pickup tubes; vacuum tubes; rectifiers; earth station microwave tubes; RF power tubes; FM & TV excitors.
[See ad on pgs. 91, 173](#)

THOR ELECTRONICS CORP. ✓
321 Pennsylvania Ave., Box 707, Linden, NJ



PRODUCT MENU

10x10 Audio Routing Switcher, the Prime Rib of the BSM line

Completely solid state designed for fingertip switching control with no mechanical relays. Any one input can drive one or more outputs without signal loss or loading of input signals. No cross talk. Low noise and low distortion. LED matrix read out. Mono or stereo.

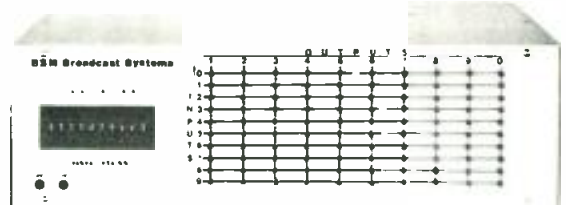

10x1 Audio Routing Switcher, the smaller cut of Prime Rib — for smaller appetites

Instant access between any of the 10 incoming lines. Output amp for extra power boost and solid state FET switching - no CMOS used. Use it as a board extender, a tape recorder buss input selector, Xmtr selector, or for the newsroom.

Audio Distribution Amplifier, the Filet Mignon of DA's

Distribute audio signals to up to 10 different places. The unit is extremely clean with isolated amp, shielded power supplies, input buffering and transformer input. Mono or stereo versions, active or transformer outputs.

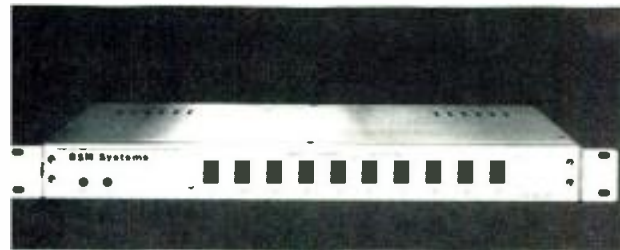

5 Channel Mixer, for take-out treats, makes portable mixing a picnic.

All units are complete main courses. No need to order ala carte. Standard rack mount, all aluminum main frames, all the PC cards, regulated power supply — everything you need, it's all included.

Computer Technology

Microprocessor control soon to be available from our menu with remote control using a single pair of wires to control all the channels. An optional 24 hour clock will enable the operator to pre-program the unit for automatic switching. The new entrees will include the following:

16 Channel Remote Station Control
10 x 1 AFV Routing Switcher
16 x 1 AFV Routing Switcher

10 x 10 AFV Routing Switcher
10 x 10 Audio Routing Switcher
Larger Switchers Available

All our units are backed with a two-week money back policy. If it doesn't set well, send it back to our chefs undamaged, and we'll mail you a check. No questions asked. Each unit is further warranted for a full year. BSM will leave you satisfied, and that's guaranteed!

**You'll never go equipment hungry again! We use the finest ingredients to insure results and long time reliability.
All PC cards are tested and cross checked prior to assembly. Each unit is cooked to insure performance.
And the price is easily digestible.**

JOIN THE LIST OF BSM CUSTOMERS, WHEN YOU'RE HUNGRY FOR A SOLUTION TO A SWITCHING PROBLEM.
CALL US — WE HAVE THE ANSWER!

(509) 448-0697

P. O. Box 8082 • Spokane, Washington 99203

**NEW
FROM TFT**

TFT

μ P REMOTE CONTROL Compatible with IBM PC



With Software Power that lets you customize control and data acquisition



For specifications, price and delivery on this and other remote control systems, call TFT – the leader in broadcast product design and manufacture.



3090 OAKMEAD VILLAGE DR.
SANTA CLARA, CA. 95051
(408) 727-7272 TWX 910-338-0584

Manufacturers

- 07036**
201 486-3300
Vacuum tubes, solid state components, rectifiers & surge protectors.
- TIFFEN MFG. CO., INC.** ✓
90 Oser Ave., Hauppauge, NY 11788
516 273-2500
Special effects and color correction filters for cine & video cameras; audio cassette player/recorders.
- TIMES FIBER COMMUNICATIONS, INC.** ✓
358 Hall Ave., Box 384, Wallingford, CT 06492
800 243-6904
Fiberoptic transmission and interconnect systems; coaxial transmission line & connectors.
- TMD, DIV. THE WILL-BURT CO.** ✓
Box 126, Wooster, OH 44691
216 262-7010
Pneumatic telescoping masts for ENG.
- TM SYSTEMS, INC.**
25 Allen St., Bridgeport, CT 06604
203 366-4571
Line amps, amp power supplies; VU & dB meters; conditioning equipment.
- TODAY VIDEO, INC.** ✓
45 W. 45 St., New York, NY 10036
212 391-1020
Teleproduction & video post-production facilities.
- TOPAZ, INC., POWERMARK** ✓
3855 Ruffin Rd., San Diego, CA 92123
619 565-8363
Inverters, converters; surge protectors.
- TOPAZ, INC.** ✓
9192 Topaz Way, San Diego, CA 92123
619 279-0831
Power conditioners; transformers & surge protectors; uninterruptible power systems.
- TORPEY CONTROLS & ENGINEERING, LTD.** ✓
2220 Midland Ave. #98, Scarborough, Ont., M1P 3E6 Canada
416 298-7788
Character generators; serial interface machine control system; digital clocks, master/slave clocks, time distribution, timers & time comparators.
- TOSHIBA AMERICA, INC.** ✓
2441 Michelle Dr., Tuscan, CA 92680
714 730-5000
Studio & ENG/EPF cameras; production switchers, digital effects processors; frame synchronizers, audio/video delay systems.
- TOWNSEND ASSOCIATES, INC.** ✓
Mainline Dr. Industrial Park, Box 1122, Westfield, MA 01086
413 562-5055
UHF, VHF & LPTV transmitters & translators; TV exciters; RF converters, filters, & loads; RF switcher; power dividers & diplexers; TV SCA equipment.
See ad on pg. 119
- TPC COMMUNICATIONS, INC.** ✓
Production Plaza, Sewickley, PA 15143
412 771-4700
Studio & mobile teleproduction facilities; video post-production facility.
- TRANS-AMERICAN VIDEO, INC.** ✓
(TAV)
1541 N. Vine St., Hollywood, CA 90028
213 466-2141
Studio & mobile teleproduction facilities; video post-production facility.
- TRANSIST-O-SOUND**
728 Yosemite Dr., Indianapolis, IN 46217
317 787-8491
Mic mixers.
- TREPAC DATATONE**
547 Windsor St., Reading, PA 19601
215 374-3439
Audio/video automatic line program alarm; tone status reporting & control modules.
- TRIDENT (USA), INC.** ✓
652 Glenbrook Rd., Stamford, CT 06906
203 357-8337
Portable, mono & stereo, automated & audio for TV mixing consoles; parametric equalizers; digital special effects, digital & analog delay & reverb, time compression/expansion.
- TRI-EX TOWER CORP.** ✓
Box 5009, 7182 Rasmussen Ave., Visalia, CA 93278
209 651-2171
Towers, masts.
- TRITRONICS, INC.**
2921 W. Alameda Ave., Burbank, CA 91505
800 423-3640
Studio & mobile teleproduction facilities; video post-production facility. Mfr. of motion analysis & microscope camera systems; telecine systems; NTSC color monitors.
- TRI VIDEO PRODUCTIONS** ✓
Box 8822, Incline Village, NV 89450
702 323-6868
Mobile video production facility.
- TROMPETER ELECTRONICS, INC.** ✓
8936 Comanche Ave., Chatsworth, CA 91311
213 882-1020
Audio patch panels.
- TRUE TIME INSTRUMENTS** ✓
3243 Santa Rosa Ave., Santa Rosa, CA 95401
707 528-1230
Phase comparators; time code receivers; clocks, timers.
- TTE, INC.** ✓
2212-14 S. Barry Ave., Los Angeles, CA 90064
213 478-8224
Comb filter decoders, video filters; RF filters; transformers.
- TVI** ✓
5426 Fair Ave., N. Hollywood, CA 91601
213 769-0928

Hardwired intercoms; lighting control boards, quartz fixtures, dimmer packs & cyc lighting; scenery construction, rigging & prop material; lighting & ac cable, jackfields; equipment rental & studio & set design.

TVNS ✓
Suite 250R, World Trade Center, San Francisco, CA 94111
415 982-3073
TV newsroom computer systems.

TWEED AUDIO USA, INC. ✓
12 Ilex Dr., Newbury Park, CA 91320
805 499-4764

Mic mixers; portable, mono & stereo, automated & audio for TV mixing consoles; AM & FM compressor/limiters, parametric & graphic equalizers; noise reduction; hardwired intercoms; preamps, line, monitor & power amps, audio DAs & amp power supplies; audio patch panels; remote control systems; studio furniture & equipment racks; facility turnkey installations, studio design, engineering consultation & mobile vehicle construction.

UAB PRODUCTIONS
8443 Day Dr., Cleveland, OH 44129
216 845-6043
Studio & mobile teleproduction facilities; video post-production facility.

UHF ASSOCIATES
5625 State Farm Dr. #4, Rohnert Park, CA 94928
707 584-7844
RF modulators.

ULTIMATE CORP. ✓
18607 Topham St., Reseda, CA 91335
213 345-5525
Encoded chromakeyers.

ULTRA AUDIO PIXTEC, DIV. AUDIO INTL. ✓
Box 921, Beverly Hills, CA 90213
213 651-5563
Mic mixers; portable, studio & TV audio consoles; monitor & power amps, audio DAs; parallel interface routing switchers; waveform monitors & vectorscopes.

UMC ELECTRONICS CO. ✓
460 Sackett Point Rd., North Haven, CT 06473
203 288-7731
Portable & studio consoles; single & multiple cart player/recorders, phase control matrixing; replacement heads; alignment & tension gauges; bulk erasers & splice finders; complete program automation systems.
[See ad on pg. 182](#)

UMDNJ/EDUCATIONAL COMMUNICATION CENTER ✓
100 Bergen St., Newark, NJ 07103
201 456-3457
Teleproduction & video post-production facilities.

UNION CONNECTOR, INC. ✓
149 Babylon Tpk., Box H, Roosevelt, NY 11575
516 623-7461

Lighting patch bays; lighting plugs/connectors; electrical connectors.

UNI-SET CORP. ✓
449 Ave. A, Rochester, NY 14621
716 544-3820
Modular studio set design.

UNITED MEDIA, INC. ✓
4075 Leaverton Ct., Anaheim, CA 92807
714 630-8020
Video editor/controllers, multisource editors; ADR looping controller; parallel & serial interface routing switchers; SMPTE time code readers, generators & synchronizers, proprietary time code systems; time distribution; engineering consultant & financial services.

UNITED PRESS INTERNATIONAL ✓
220 E. 42 St., New York, NY 10017
212 850-8600
Wire services, radio news networks, photo services.

UNITED RESEARCH LAB ✓
16 E. 52 St., New York, NY 10022
212 751-4663
2, 4-track studio ATRs & replacement heads; distributor of audio products & test equipment.

UNTEL VIDEO, INC. ✓
510 W. 57 St., New York, NY 10019
212 265-3600
Studio & mobile teleproduction facilities; video post-production facility; film to tape transfer & color correction.

UNR-ROHN, DIV. UNR, INC. ✓
Box 2000, Peoria, IL 61656
309 697-4400
Towers, hardware & construction equipment; tower lighting.

UREI, INC. ✓
Box 2200, 8500 Balboa Blvd., Northridge, CA 91329
213 767-1000
Portable & stereo studio consoles; ALC & AGC amps; AM & FM compressor/limiters, parametric & graphic equalizers & noise reduction systems; speakers; preamps, monitor & power amps; slide attenuators; audio test signal generators; chart recorders; digital metronomes; transformers; recording studio, video post-production facility.
[See ad on pg. 145](#)

Refer to Reps/Distributors section
Field Offices:
MI Tom Roseberry, 3040 Charevoix Dr., S.E., #101
Grand Rapids 49506... 616 455-6270
PA Bill Hamilton, 615 7 Ave., Folsom 19033... 215 543-4677
TX Neil Conley, 3117 Murphy, Bedford 76021... 817 540-3066
WA Steve Armstrong, 4203 N.E. 24, Renton 98506... 206 226-9953

URSA MAJOR, INC. ✓
Box 18, 50 Trapelo Rd., Belmont, MA 02178
617 489-0303
Digital audio special effects & digital reverb.

TFT
AM STEREO



C-QUAM®
Exciter and Monitor

FM STEREO



Composite FM Stereo and Multiple SCA Modulation-Frequency Monitors with tunable RF Preselectors

For specifications, price and delivery on these and other quality broadcast products, call TFT – the leader in broadcast product design and manufacture.



3090 OAKMEAD VILLAGE DR.
SANTA CLARA, CA. 95051
(408) 727-7272 TWX 910-338-0584

Circle 201 on Reader Service Card

Manufacturers

VIDCOM

2426 Townsgate Rd., Ste. K, Westlake Village, CA 91361
213 991-1974
Mobile production facilities.

VIDEO AIDS OF COLORADO

1930 Central Ave., Boulder, CO 80301
303 443-4950
Hardwired intercoms; sync & black burst generators; pulse amps & video DAs; phase meters; burst phase meters.

VIDEO CENTRAL PRODUCTIONS

112 N. Collett, Dallas, TX 75214
214 824-0942
Studio & mobile teleproduction facilities.

VIDEOCOM, INC.

502 Sprague St., Dedham, MA 02026
617 329-4080
Studio & mobile teleproduction facilities; video post-production facility.

VIDEO CORP. OF AMERICA (VCA)

1913 Route 27, Edison, NJ 08823
201 572-3300
Audio & video equipment rental; video post-production facility; engineering consultant.

VIDEO IMAGES, INC.

8409 Dixon Ave., Silver Springs, MD 20910

301 565-3310

Studio & mobile teleproduction facilities; video post-production facility.

VIDEO INTERNATIONAL

1280 Sunrise Hwy., Copiague, NY 11726
516 842-1815
Portable, digital TV standards converters.

VIDEOMEDIA

211 Weddell Dr., Sunnysvale, CA 94086
408 745-1700
Video editor/controllers & multisource editors; SMPTE & proprietary time code systems.

VIDEO ONE

10834 Burbank Blvd., D 201, N. Hollywood, CA 91601
213 980-0704
Mobile video production facility.

VIDEO POST & TRANSFER

8036 Aviation Pl., Box 53, Dallas, TX 75235
214 350-2676
Video post-production facility; film to tape transfer; computer video animation.

VIDEOSMITH

2006 Chancellor St., Philadelphia, PA 19103
215 864-0658
Studio & mobile teleproduction facilities; video post-production facility.

THE VIDEO TAPE CO.

10545 Burbank Blvd., N. Hollywood, CA 91601
213 985-1666
Video post-production facility; duplication; film-to-tape transfer; standards conversion; distribution services.

VIDEOTEK, INC.

125 N. York St., Pottstown, PA 19464
215 327-2292
Audio program monitors; NTSC, RGB & dc portable video monitors; demodulators; waveform monitors & vectorscopes.
See ad on pg. 37

VIDEOTEX/AMERICA

2050 Center Ave., Suite 200, Fort Lee, NJ 07024
201 461-0217
Hardware & software for videotex systems.

VIDEO TRANSITIONS

910 N. Citrus Ave., Hollywood, CA 90038
213 465-3333
Video post-production facility.

VIDEO WEST

55 S. State St., Salt Lake City, UT 84111
801 237-2526
Studio & mobile teleproduction facilities; video post-production facility.

Suddenly, phone relay is much easier to understand.

The TES telephone line enhancement system is the broadcast journalist's best friend. It's a low cost method to turn even poor phone relays into transmission that's clearly understandable.

To achieve optimum intelligibility, the TES employs a compression/expansion system that improves signal-to-noise ratio. It utilizes two ordinary phone lines to expand frequency response to an unprecedented 100 to 5100 Hz. Three lines can be ganged to increase frequency response to 7600 Hz.

Your news gathering teams go to great lengths to cover the news. The least you can do is make sure that their phone relays come in sharp and clear. For details, contact: Tandberg of America, 1 Labriola Ct., Armonk, NY 10504/(914) 273-9150.

TANDBERG

Telephone Line Enhancement System

Receiver



Transmitter

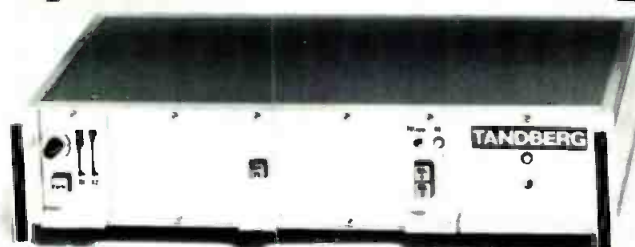

Circle 204 on Reader Service Card

DAY and NIGHT SERVICE FOR Continental AM & FM TRANSMITTERS

Continental Electronics offers 24-hour professional engineering service and parts for Continental and Collins AM & FM transmitters. Whenever you need service or parts for your Continental or Collins equipment, phone our service numbers day or night.

(214) 327-4533
(214) 327-4532 parts

Continental Electronics Mfg. Co.
Box 270879 Dallas, Texas 75227
Phone (214) 381-7161

Continental Electronics

1 kW thru 50 kW AM & FM transmitters and related equipment
©1983 Continental Electronics Mfg Co 5332

Circle 205 on Reader Service Card

Finally. On-Air Boards Designed By Broadcasters!

The UREI Broadcast Consoles

Before we started designing the new Series 1650 and 1680 consoles, we talked to you... engineers, jocks, announcers and consultants. Then we went to the drawing boards to plan a line of on-air boards with the features you wanted... built with UREI's traditional quality and reliability.

The result is a fresh answer to the operational requirements of the broadcaster of the '80's. Six all-new on-air boards... choice of 5 mixers (1650 Series) or 8 mixers (1680 Series)... choice of Penny & Giles slide pots, Shallco or conductive plastic rotary attenuators... +24 dBm output... better than 90 dB signal to noise ratio... inputs from +8dB down to -10 dB... built-in cueing amp and speaker.

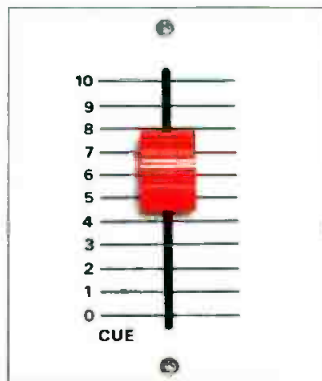

Best of all, both Series are competitively priced!

Ready to Go

You can customize the new UREI consoles, but no accessories are required to go on the air. They are supplied with full sets of input preamps. All preamps are interchangeable in all positions. We even designed a new acces-

sory phono preamp for these new boards that mounts at the turntable and takes its power from the console. Ask about the Model 1101 Phono Stereo Preamplifier.

The Modern Ones

You've been asking for a new line of UREI on-air consoles for years. We took the time to make them "the modern ones"... the ones that will meet your requirements through the 80's and beyond. For more information on the UREI Broadcast Consoles, see your authorized UREI dealer, or write:

From One Pro to Another

UREI

United Recording Electronics Industries
8460 San Fernando Road
Sun Valley, California 91352
(213) 767-1000 TLX 472 0889 UREI SNVY
Canada: E. S. Gould Marketing, Montreal



Manufacturers

VIF INTERNATIONAL ✓
 Box 1555, Mountain View, CA 94042
 408 739-9740
 Portable & 2.4-track studio ATRs; replacement audio heads; audio test tapes, bulk erasers; phono cartridges; relay sequencers; ALC & AGC amps, AM & FM compressor/limiters, parametric equalizers; monitor speakers, headphones. Tower hardware; tape-based loggers.

VIKING CASES ✓
 Box 13457, St. Petersburg, FL 33733
 813 327-8810
 Reuseable shipping cases.

VISCOUNT INDUSTRIES, LTD. ✓
 Box 1555, Mountain View, CA 94042
 604 327-9446
 Video DAs; routing switchers; manual master control switchers; small & portable production switchers; special effects generators.

VISION-SOUND, INC. ✓
 20 North Dean St., Englewood, NJ 07631
 201 871-4101
 Audio equipment sales.

VISUAL INFORMATION INSTITUTE, INC. ✓
 Box 33, Xenia, OH 45385
 513 376-4361
 Sync, color bar, multiburst & staircase ramp generators; signal multiplexers; video test signal generators.

VITAL INDUSTRIES, INC. ✓
 3700 NE 53 Ave., Gainesville, FL 32601
 904 378-1581
 Large, small & automated production switchers, chromakeyers & title keyers, special effects generators; digital effects processors; audio DAs; manual, automated & business automation interfaced master control switchers; serial interface routing switchers; SMPTE time code readers, generators & synchronizers; pulse amps & video DAs.

WALLACH & ASSOC., INC. ✓
 Box 18167, Cleveland, OH 44118
 216 575-0765
 Audio carts, empty reels & tape storage units.

WARD-BECK SYSTEMS, LTD. ✓
 841 Progress Ave., Scarborough, Ont., M1H 2X4 Canada
 416 438-6550
 Portable, mono & stereo audio mixing consoles; variable equalizers; manual & microprocessor-controlled hardwired intercoms; preamps, line, monitor & power amps; audio DAs & amp power supplies; audio patch panels & VU meters.
 See ad on pg. Cover 4
 Refer to Reps/Distributors section
 Field Offices:
 MA William McFadden, 755 Washington St., Annisquam
 01930 617 283-7507
 TX Duke McLane, 4012 Mendenhall Dr., Dallas 75234 214 241-5999

WATERS MANUFACTURING, INC. ✓
 Longfellow Center, Wayland, MA 01778
 617 893-6900
 Rotary & slide attenuators.

WAVETEK INDIANA, INC.
 Box 190, 5808 Churchman, Beech Grove, IN 46107
 317 787-3332
 RF attenuators; video test signal generators; oscilloscopes.

WAVETEK ROCKLAND, INC.
 Rockleigh Ind. Ctr., Rockleigh, NJ 07647
 201 767-7900
 Active equalizers & filters, audio & RF; sideband analyzers; spectrum analyzers; frequency synthesizers.

WEATHERSCAN INTERNATIONAL ✓
 2445 NW 39 St. Expy., Oklahoma City, OK 73112
 405 521-9081
 Weather information services; broadcast-quality weather graphics.

WEGENER COMMUNICATIONS ✓
 150 Technology Park/Atlanta, Norcross, GA 30092
 404 448-7288
 Audio & data satellite transmission equipment; teletext equipment.

WESTEC AUDIO VIDEO, INC.
 1841 Broadway, Ste. 1203, New York, NY 10023
 212 586-1662
 Equipment rental service; audio & video post-production facilities; recording studio; engineering consultant.

WESTERN TELECOMMUNICATIONS, INC.
 Box 22595, Wellshire Sta., Denver, CO 80222
 303 771-8200
 Satellite communication service; microwave & fiberoptic systems.

WESTERN UNION ✓
 1 Lake St., Upper Saddle River, NJ 07658
 201 825-5000
 Digital & analog video & audio transmission via satellite.

WESTERN VIDEOTAPE PRODUCTIONS
 101 Howard St., Ste. B, San Francisco, CA 94105
 415 543-2810
 Teleproduction & video post-production facilities.

WESTINGHOUSE ELECTRIC CORP., IGT DIV. ✓
 Westinghouse Circle, Horseheads, NY 14845
 607 796-3211
 Single-tube & monochrome video cameras; vacuum tubes.

WESTLAKE AUDIO, INC. ✓
 2696 Lauery Ct., Bldg. 18, Newbury Park, CA 91320
 805 499-3686
 Studio reference monitors; accessories.

WESTON INSTRUMENTS ✓
 614 Frelinghuysen Ave., Newark, NJ 07114
 201 242-2600
 VU & PPM meters, LED & video monitor displays; frequency monitors, controllers; voltmeters, multimeters & dB meters.

WGN CONTINENTAL PRODUCTIONS CO. ✓
 2501 W. Bradley Pl., Chicago, IL 60618
 312 883-3411
 Studio & mobile teleproduction facilities; video post-production facility.

WHIRLWIND ✓
 100 Boxart St., Rochester, NY 14603
 716 663-8820
 Direct & breakout boxes; multiline mic cables & patch panels.

WHITE INSTRUMENTS, INC. ✓
 Box 698, Austin, TX 78767
 512 892-0752
 Graphic equalizers; real time analyzers; pink noise generators.

WICKERWORKS VIDEO PRODUCTIONS, INC.
 7342 S. Alton Way, Englewood, CO 80122
 303 741-3400
 Teleproduction & video post-production facilities.

When accuracy counts... Count on Belar for AM/FM/TV MONITORS



BELAR
 AM MODULATION MONITOR

BELAR CALL ARNO MEYER (215) 687-5550
ELECTRONICS LABORATORY, INC.
 LANCASTER AVENUE AT DORSET, DEVDN, PA. 19333 • 80X 826 • (215) 687-5550

Circle 207 on Reader Service Card

Excellence in telecommunications systems...

Centro Corporation is an engineering firm specializing in the design, construction and installation of fixed and mobile telecommunications and teleconferencing systems.

Our extensive capabilities provide a variety of services to assist in the design and construction of telecommunications systems. Such services include the assessment of space requirements and relationships, architectural delineations, electrical and air

conditioning specification development, acoustical performance specifications, system design specifications and interior design.

Centro is an acknowledged authority in the consideration of human factors as an integral element in systems design.

Comprehensive systems engineering documentation is prepared by Centro, typically including functional and wiring diagrams, equipment elevations and floor plans, human factors studies and fabrication and assembly documents. Efforts are expended to literally "build the system on paper" prior to actual construction, permitting Centro's clients to see precisely how the envisioned system is to be built.

Centro maintains a complete "turn-key" fabrication and installation capability. Consoles, equipment

enclosures and supportive casework are constructed in Centro's metal and cabinetry shops by master craftsmen. Highly trained and skilled Centro installation teams provide on-site installation capability throughout the world.

Centro maintains a project management staff to ensure timely scheduling and guidance of a project from inception to completion.

We want to provide you with the finest telecommunications capability in the world.

Call Centro today for a more productive tomorrow.

Centro

a subsidiary of SKAGGS TELECOMMUNICATIONS SERVICE
SAN DIEGO, CALIFORNIA (619) 560-1578

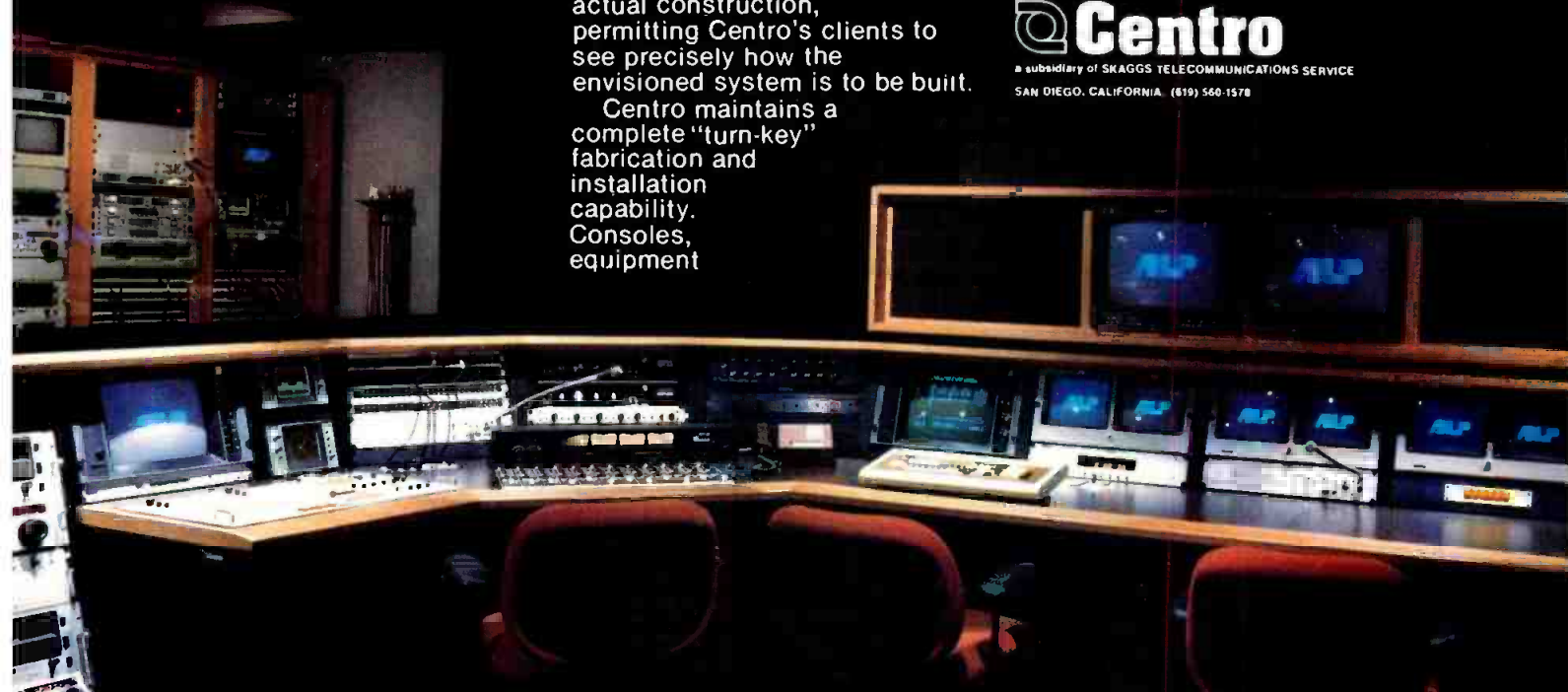

GOOD THINGS COME IN SMALL PACKAGES



LOWEL VIDEO KITS, LIGHTWEIGHT & EXTREMELY PORTABLE. UNQUESTIONABLY THE STATE-OF-THE-LIGHT.

LOWEL-LIGHT MFG., INC. 475 TENTH AVE., N.Y. N.Y. 10018. 212-947-0950.
LOWEL WEST, 3407 W. OLIVE AVE. BURBANK, CA. 91505. 213-846-7740



Circle 209 on Reader Service Card

Videotape Editing

Videotape Editing-Communicating With Pictures And Sound answers every videotape editing question.

When to edit? When to (and when not to) use a dissolve or wipe? How to cut? How to use complex sync roll editing and audio sweetening? How to affect the mood and pace of a show? Why and how to perform computer editing without losing creative control? It even takes the mystery out of time code and user bits.

Beginning editors, experienced pros, film editors and media managers will all appreciate *Videotape Editing*. This new book is your guide through the world of videotape editing including time code and computer assistance.

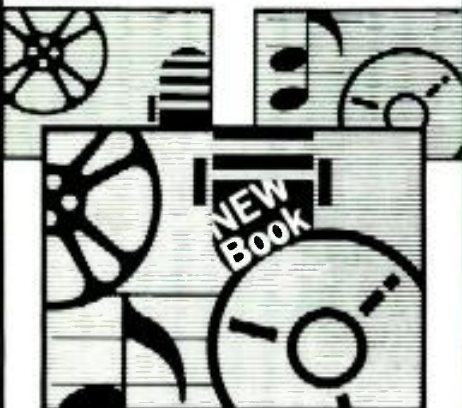

Videotape Editing-Communicating With Pictures And Sound By Michael D. Shetter
• 165 pp. • 144 illus. • 6"x9" Hardbound
\$32.20 (\$34.00 in IL)
Order Today! • Major Credit Cards Accepted
Brochure Available • (312) 364-1900 Ext. 825

SE Swiderski Electronics
Audio/Video Engineers

1200 Greenleaf Ave. • Elk Grove Village, IL 60007 • (312) 364-1900

Circle 210 on Reader Service Card

Manufacturers

WIDE BAND ENGINEERING CO., INC.

Box 21652, Phoenix, AZ 85036
602 254-1570
RF test instruments.

WIDE RANGE ELECTRONICS CORP.

2119 Schuetz Rd., St. Louis, MO 63141
314 567-5366
Sprocketed magnetic film transports; head degaussers & bulk erasers; SMPTE time code generators & readers.

WINDSOR TOTAL VIDEO

565 Fifth Ave., New York, NY 10017
212 725-8080
Studio & mobile teleproduction facilities; video post-production facility.

WINEGARD CO

3000 Kirkwood St., Burlington, IA 52601
319 753-0121
PTV, MATV equipment; CATV antennas; receive only earth stations.

WINSTED CORP.

9801 James Circle, Minneapolis, MN 55431
612 888-1957/800 328-2962
Transportation cases; editing, production consoles; studio furniture, consoles, tape storage units & equipment racks.

WIREWORKS CORP.

380 Hillside Ave., Hillside, NJ 07205
201 686-7400
Audio patch panels; audio & video cable, connectors & jackfields.

WKYT-TV

Box 5037, Winchester Rd., Lexington, KY 40555
606 299-0411
Studio & mobile teleproduction facilities; video post-production facility.

WOLD COMMUNICATIONS, INC.

10880 Wilshire Blvd., Los Angeles, CA 90024
213 474-3500
Transmit/receive, receive only & transportable satellite earth stations; microwave, satellite & telco STLs; intercity & portable ENG microwave; engineering consultant, earth station site selection & satellite time broker.

WOLF COACH, INC.

7 B St., Auburn, MA 01501
617 791-1950
Mobile vehicle construction.

FRANK WOOLEY & CO. INC.

529 Franklin St., Reading, PA 19602
215 374-8335
Special graphics effects/animation system.

WORLD TOWER CO., INC.

Box 405, Mayfield, KY 42066
502 247-3642
Towers & masts.

WORLD VIDEO, INC.

Box 117, Boyertown, PA 19512
215 367-6055
Audio monitor & power amps & program

monitors; color bar generators; NTSC & RGB monitors; blanking meters, adjusters & SCH verification modules.

WPHL PRODUCTIONS

5001 Wynnefield Ave., Philadelphia, PA 19131
215 878-1700
Studio & mobile teleproduction facilities; video post-production facility.

WSI CORP.

41 North Rd., Box B, Bedford, MA 01730
617 275-5300
Weather & sports information, hardware & services; syndicated radio programming.

WXXI PRODUCTION CENTER

280 State St., Rochester, NY 14601
716 325-7500
Mobile video production facility.

XEDIT CORP.

133 S. Terrace Ave., Mt. Vernon, NY 10550
914 668-0388
Splicing blocks, tape; wow & flutter meters.

XIPHIAS

13470 Washington Blvd., Marina Del Rey, CA 90291
213 399-3283
Digital art/paint systems, bit pad digitizers & weather symbol inserters.

YAMAHA INT'L CORP., COMBO DIV.

6600 Orangethorpe, Buena Park, CA 90620
714 522-9100
Mic mixers; portable & studio consoles; graphic equalizers, analog special effects; speakers; monitor & power amps.
[See ad on pgs. 43, 44](#)

YES PRODUCTIONS

916 Navarre, New Orleans, LA 70124
504 486-5511
Studio & mobile teleproduction facilities; video post-production facility.

ARTHUR YOUNG & ASSOC.

1950 Roland Clarke Pl., Reston, VA 22091
703 620-3888
Video post-production facility.

THE ZEI-MARK CORP.

Box 182, Brookfield Ctr., CT 06805
203 355-0008
Lenses; 16/35 mm telecine projectors; 35 mm slide projectors; optical multiplexers.

ZELLAN ENTERPRISES

250 W. 57 St., New York, NY 10019
800 221-3349/212 245-1598
Audio tape recorders (Stellavox); cine cameras and lenses.

ZENITH RADIO CORP.

1000 Milwaukee Ave., Glenview, IL 60025
312 391-7000
STV encoders & decoders

ZRC CHEMICAL PRODS. CO.

21 Newport Ave., Quincy, MA 02171
617 328-6700
Regalvanizing antenna guy wires.

The Leader Sync/Test Generators.

Every important feature for under \$2,000.

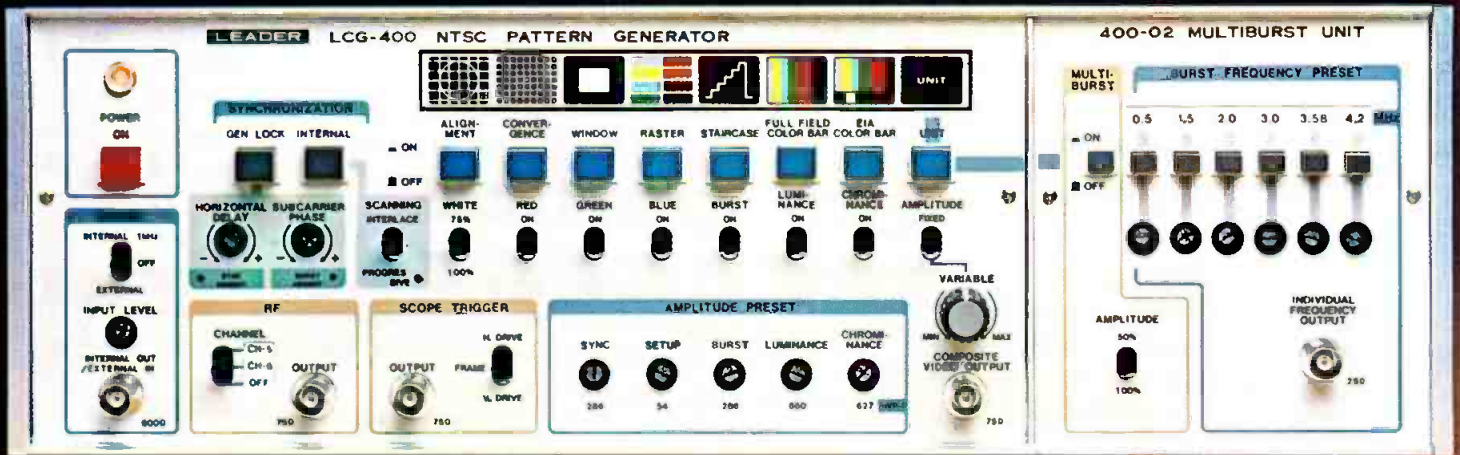

Precise NTSC sync/test pattern generators.

Leader's LCG-400 series sync/test generators provide accurate reference signals for any off-the-air broadcast or non-broadcast operation. Available in either multi-burst or sweep marker configurations, the LCG-400 provides EIA and full-field color bars as well as staircase, raster (in eight colors), window, convergence and cross-hatch test signals... plus gen-lock capabilities and a host of auxiliary outputs. As a matter of fact, Leader's sync/test generators do virtually everything the \$4,000 generators do... except cost as much.

A network-proven 50 MHz oscilloscope.

The Leader LBO-517 oscilloscope makes accurate and detailed measurements. It offers sensitivities of 1 mV to 10 MHz and 5 mV to 50 MHz. Two main and two auxiliary channels can be displayed on main and delayed time bases (8 traces) simultaneously while intensifying

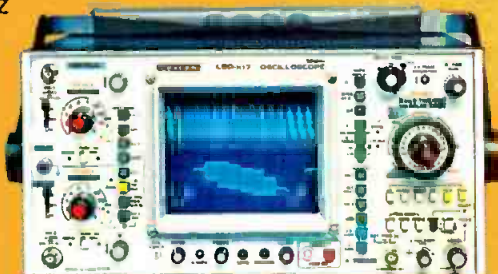

LBO-517 50 MHz Oscilloscope.

the delayed portion. Composite triggering provides *stable* viewing of two asynchronous inputs. Positive, stable triggering on composite video signals, at either H or V rates, is automatic. Leader's new dome-mesh 20 kV CRT assures bright, clearly defined displays, even at the highest or lowest sweep rates. Very competitively priced.

The Leader Vectorscope is unique.

Only the Leader LVS-5850 NTSC Vectorscope offers CRT-generated phase/amplitude targets that are as bright and clear as the vectors themselves. Now you can easily verify NTSC Vectors in darkened control rooms. And, electronically generating the targets eliminates non-linearity errors caused by CRT aging. You can mount it in your existing console, view it from any angle



LVS-5850 NTSC Vectorscope.

or distance, and be confident that what you see is what you've got.

Two-year warranty. Evaluation units.

A history of high reliability permits Leader to provide a generous two-year warranty (even on the CRT)... backed by factory service depots on the East and West Coasts.

Evaluation units are available to all qualified customers.

Call toll-free (800) 645-5104 to request: an evaluation unit, our latest catalog, the name of your nearest "Select" distributor and additional information.

For video engineers who know the difference.

LEADER
Instruments Corporation

380 Oser Avenue
Hauppauge, N.Y. 11788 (516) 231-6900
Regional Offices:
Chicago, Los Angeles, Dallas.

Circle 211 on Reader Service Card

THE WORLD'S ONLY FULLY DIGITAL TELECINE IS NOW IN AMERICA!

It's the MARCONI LINE ARRAY TELECINE B3410—the telecine that not only delivers a new standard of quality for film-to-tape transfers but can appreciably add to your productivity and profits!

The reasons are simple. The Marconi B3410's fully digital processing and CCD image sensors deliver an extraordinarily true video picture. And the Marconi B3410 does not require time-consuming tweaking, day-to-day adjustments and set-up arrangements that rob you of valuable hours of productive work.

The Marconi B3410 delivers full performance within two minutes from the time you switch on. Moreover, there is no registration

drift and no tubes to replace. It interfaces with all available color correctors, converts into all international standards and—by its very digital nature—is designed to have an exceptionally long life.

And, because the Marconi B3410 is distributed and supported by A.F. Associates—America's largest designers and builders of video systems—there is no lack of engineering backup and spares on both the East and West coasts!

Call us today for prices, availability, delivery: Richard Lunniss or Marc Bressack in New Jersey (201) 767-1000 or Noel Parente in California (213) 466-5066.



THE MARCONI LINE ARRAY TELECINE B3410



AFA PRODUCTS DIVISION

A DIVISION OF A.F. ASSOCIATES, INC.

100 OAK STREET, NORWOOD, NJ 07648
1438 NORTH GOWER STREET, HOLLYWOOD, CA 90028

Circle 212 on Reader Service Card
www.americanradiohistory.com

REPS/DISTRIBUTORS

Listed here are full line distributors and reps for products advertised in The Source. Because of the trend to multiple product supplier capability, cross references to product advertising have been eliminated to avoid confusion. To ascertain local availability of the products of your choice, we suggest that you contact the distributor or rep in your area.

ALABAMA

BEATTIE & ASSOC.

Tallahassee, FL
904 893-1382

EME II, INC.

Decatur, GA
404 325-0165

F.M. ASSOC., INC.

Huntsville
205 882-0689/205 882-0629

RALPH HUCABY

Nashville, TN
615 373-0231

REMTEK, INC.

Dallas, TX
214 387-2855

E.J. RUTH ASSOC.

Birmingham
205 979-0880

SONICS ASSOC., INC.

Birmingham
205 942-9631

WKH BROADCAST ENGINEERING SERVICE

Andalusia
205 222-5288

ALASKA

MARCOM

Seattle, WA
206 722-2636

MULTIVISION

Anchorage
907 276-0400

NU-COM ASSOC., INC.

Seattle, WA
206 364-9911

ARIZONA

BROADCAST MARKETING ASSOC.

San Jose, CA
408 946-2236

HP MARKETING

Tempe
602 990-1198

INDUSTRIAL PRODUCTS CORP.

Phoenix
602 954-7300

ROD MACDONALD

Phoenix
602 998-1848

MARCOM

Woodland Hills, CA
213 703-0381

MZB & ASSOC.

Dallas, TX
214 233-5535

SPENCER BROADCAST

Phoenix
602 242-2211

ARKANSAS

DUSTY ARNOLD

Richardson, TX
214 644-7607

PARCOM

Southlake, TX
817 481-7221

RADCOM, INC.

Eureka Springs
501 253-8556

REMTEK, INC.

Dallas, TX
214 387-2855

CALIFORNIA

ADVANCED MARKETING

Redwood City
415 365-3944

AF ASSOC., INC.

Hollywood
213 466-5066

AUDIO ENGINEERING ASSOC.

Pasadena
213 798-9127

A-VIDD ELECTRONICS CO.

Newport Beach
714 851-1295

BROADCAST CARTRIDGE SERVICE

Huntington Beach
714 898-7224

BROADCAST MARKETING ASSOC.

San Jose
408 946-2236

EVERYTHING AUDIO

Encino
213 995-4175

ADOLPH GASSER, INC.

San Francisco
415 495-3852

HOFFMAN VIDEO SYSTEMS, INC.

Los Angeles
213 749-3311

JUST NOTICEABLE DIFFERENCE

Fairfax
415 459-3186

KNOTT ENGINEERING

Santa Ana
714 838-9289
San Diego
714 268-1199

LEDDY ASSOC.

Mountain View
415 969-6313

L.P. MARKETING

Oakland
415 532-5600

MARCOM

Scotts Valley
408 438-4273
Woodland Hills
213 703-0381

MCS MARKETING

N. Hollywood
213 980-1188

NEW WORLD AUDIO

San Diego
619 569-1944

OMEGA VIDEO

Lawndale
213 679-9021

PACIFIC COMPUTER MARKETING

San Pedro
213 519-0679

RADON & ASSOC.

Mill Valley
415 383-8877

RDX CORP.

Pasadena
213 681-3451
San Diego
619 278-6863

Landy Associates, Inc.

- SYSTEMS DESIGN
- INSTALLATION AND SERVICE FEATURING IKEGAMI CAMERAS & MONITORS
- ANTON-BAUER BATTERIES
- BMS, INC. (MICROWAVE)
- CROWN
- DATATEK
- JBL
- PETER LISAND
- PANASONIC
- JVC
- SKOTEL
- TEKTRONIX
- VIDEOTEK
- LEADER

And all of the finest in Broadcast, Production, and Recording Equipment.

Jim Landy
1890 E. Marlton Pike
Cherry Hill, NJ 08003
609-424-4660

Brad Reed
801 Water Street
Framingham, MA 01701
617-877-9570

Circle 214 on Reader Service Card

LAUMIC HAS THE EDGE IN VIDEO EDITING EQUIPMENT



Now you can **RENT** a CMX Portable 3 machine system from Laumic Company

"THE EDGE"™ computer assisted editing system with internal memory, re-edit, list ripple, time code pulse count editing, auto assembly, floppy disk, printer, GPI and built-in A/V dissolver; interfaced with ADDA's TWIN TBC and DIGITAL EFFECTS SWITCHER; WAVEFORM & VECTORSCOPE; 3 SONY 5850's SYNC GEN.; and VIDEO & AUDIO MONITORS.

It's yours for short or long term rental. Call today.

SALES, SERVICE AND RENTALS OF JVC, SONY, HITACHI. INDUSTRIAL/BROADCAST VIDEO EQUIPMENT SYSTEMS DESIGNED AND INSTALLED.

LAUMIC COMPANY, INC.

306 EAST 39th STREET, NEW YORK, N.Y. 10016 • TEL. (212) 889-3300

Circle 215 on Reader Service Card

Reps/Distributors

Sunnyvale
408 734-4500

SHORELINE LTD.
Hollywood
213 851-1236

SKAGGS VIDEO SALES
Los Angeles
213 556-2133

SOUND GENESIS
San Francisco
415 285-8900

STAR ENTERPRISES
Yorba Linda
714 996-5622

TRI-TRONICS, INC.
Burbank
213 843-2170

VIDEO STORE
San Diego
714 560-4454

WESTERN AUDIO SALES
Burbank
213 843-3002

WESTERN BROADCAST SYSTEMS
Cupertino
408 749-0900

WESTLAKE AUDIO
Los Angeles
213 851-9800

COLORADO

ABCO, INC.
Boulder
303 444-1173

CEAVCO AUDIO VISUAL CO., INC.
Denver
303 238-6493

DAVIS ASSOC.
Littleton
303 795-1400

DIDIER/DENVER
Evergreen
303 674-6000

HALL ELECTRONICS
Boise, ID
208 336-5894

HP MARKETING
Littleton
303 794-8367

SILVER PEAK MARKETING LTD.
Lakewood
303 233-8577

WESCOM MARKETING, INC.
Arvada
303 422-7619

CONNECTICUT

ABBOTT ALLISON CO., INC.
Meriden
203 237-9232

JOHN B. ANTHONY CO.
Stamford
203 322-9202

APPLIED MEASUREMENTS, INC.
Hamden
203 288-5288

AUDIOTECHNIQUES
Stamford
203 359-2313

BARTLETT ASSOC.
White Plains, NY
914 949-6476

HOLZBERG ASSOC.
Totowa, NJ
201 256-0455

THE SMITH CO.
W. Hartford
203 523-0512

UMC ELECTRONICS CO.
North Haven
203 288-7731

VIDEOPLAY SYSTEMS, INC.
Rockville
203 872-9195

DELAWARE

BARTLETT ASSOC.
White Plains, NY
914 949-6476

HOLZBERG ASSOC.
Totowa, NJ
201 256-0455

WILTRONIX, INC.
Washington Grove, MD
301 258-7676

DISTRICT OF COLUMBIA

BARTLETT ASSOC.
White Plains, NY
914 949-6476



Until now, no component video system on Earth has been complete.

*Editing suite courtesy
of WNEV-TV, Boston, MA*

Shintron 390. The world's first and only component video switcher and editor-interface.

Now your M-format, BetaCam, or Quarter-Cam tapes can receive the full range of editing, effects, and other post-production techniques used on standard NTSC materials. Never possible before, because there was no such thing as the Shintron 390.

The Shintron 390 is the first switcher that can handle the three separate video component channels simultaneously; for M-format (Y, I, and Q),

BetaCam (Y, R-Y, and B-Y), and for general purpose (R, G, B). It can be driven by time code, and its special Convergence port along with a standard RS-422 port permit direct interface with most professional editors. And, its two independent microprocessors make it smart enough to perform a wide variety of intelligent, programmable functions.

The Shintron 390 is the missing link. Without it, no component video system is complete. Call now for more information.

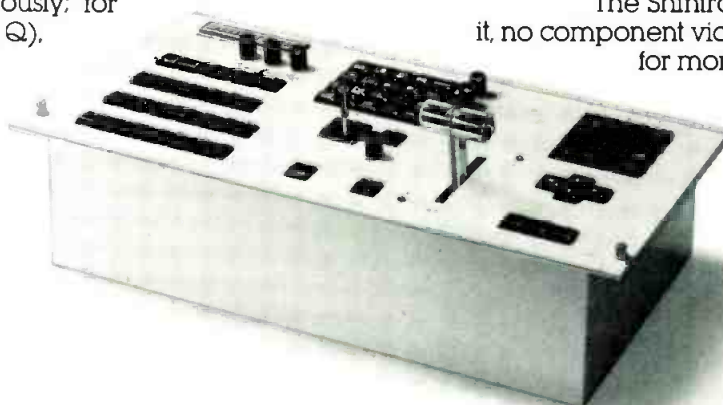

Shintron 390 lets you mix, wipe, key, edit, and post-produce component video tapes with the same flexibility of NTSC systems.

SHINTRON

SHINTRON Company, Inc.: 144 Rogers Street, Cambridge, MA 02142/Tel: (617) 491-8700/Telex: 921497
Shintron Europe: 198 Avenue Brugmann, 1180 Brussels, Belgium/Tel: 02-347-2629/Telex: 61202

Circle 213 on Reader Service Card

www.americanradiohistory.com

Reps/Distributors

INSTRUCOM, INC.
Washington
202 223-1759

RECORDING CONSULTANTS, INC.
Silver Spring, MD
301 537-1800

WILTRONIX, INC.
Washington Grove, MD
301 258-7676

FLORIDA VIDEO SYSTEMS
Jacksonville
305 688-6618
Miami
305 688-6618

F.M. ASSOCIATES LTD.
Orlando
305 851-5710
305 851-5716
Tequesta
305 746-2996

GLOBAL VIDEO
Orlando
305 843-8982

HUBBARD COMMUNICATIONS, INC.
St. Petersburg
813 577-7759

HUTTO HAWKINS PEREGOY, INC.
Mailand
305 831-2474

RICHARD KAUFLE
Miami Beach
305 672-4560

LAUDERDALE ELECTRONIC LABS
Ft. Lauderdale
305 764-7755

MIDWEST CORP.
Miami
304 592-5355

POWERCOM ENGINEERING
Ft. Lauderdale
305 463-6059

PRO AUDIO GENERAL STORE
Coral Springs
305 752-0330

R & H ASSOC.
Safety Harbor
813 442-7505

REMTEK, INC.
Dallas, TX
214 387-2855

REPELECT
Tampa
813 227-5051

SINGER PRODUCTS CO., INC.
Medley (South America)
305 885-0030

SPROCH SALES, INC.
Ft. Lauderdale
305 587-3792

TROPICAL VIDEO EXPORTERS, INC.
Miami
305 687-1795

FLORIDA

BEATTIE & ASSOC.
Tallahassee
904 893-1382

BROADCAST INTERNATIONAL, INC.
Ft. Lauderdale
305 564-4422

CONTROL TECHNOLOGY, INC.
Ft. Lauderdale
305 587-2716

GEORGIA

ALLIED BROADCAST EQUIPMENT
Union City
404 964-1464

BEATTIE & ASSOC.
Tallahassee, FL
904 893-1382

EME II, INC.
Decatur
404 325-0165

F.M. ASSOC. LTD.
Doraville
404 451-2293/404 451-4180

SMPTE EDIT-CODE READER AND CHARACTER GENERATOR



PRICE REDUCED
FROM \$3,295
TO \$2,795

13:45:27.09

WARRANTY INCREASED
FROM 1 YEAR
TO 5 YEARS

THE STANDARD OF THE INDUSTRY

FEATURES: "The McFadin Window"™ wide range digital decoder, highly legible and unique FONT, 1-3/4 inch rack mounting, vertical interval display, all front panel controls, drop-frame indicator, choice of time-code or user-bits, regenerated time code output (DUB). MODEL DR-107



504 WEST CHAPMAN AVENUE, SUITE P
ORANGE, CALIFORNIA 92668
(714) 997-4151

Circle 217 on Reader Service Card



YOU'LL NEVER GET A BETTER DEAL BROADCAST TYPE TUBES

Ceco Communications is the largest franchised distributor stocking a full line of transmitting tubes, industrial tubes, camera tubes, receiving tubes and CRT tubes. Ceco is the one source for all your electronic needs. We offer off-the-shelf, overnight delivery on most items.



3CX2500F3/8251



4CX5000A/8170

Please call for quotes on all semi-conductors, integrated circuits & connectors. A full line of broadcast supplies such as microphones & headsets are available.

Please call for your video needs!
We are also a large distributor of video equipment.



COMMUNICATIONS, INC.
2115 AVENUE X
BROOKLYN, N.Y. 11235

Call 24 hours for your price quotes.
Toll Free (800) 221-0860
(212) 646-6300 • Telex: 235125

Circle 218 on Reader Service Card

Introducing the New Electro-Voice RE30 omni and RE34 cardioid ENG/EFP microphones

“Sophisticated microphones that simplify field production.”

Action doesn't wait. The constant deadlines faced by news gathering and field production crews demand equipment compatibility, fast set-ups, simple operation and absolute reliability.

Electro-Voice knows.

We've designed and built the broadcast microphones that have set performance and reliability standards, and we stand behind EV Professional Microphones with a warranty and service policy that's second to none.

And EV listens.

Properly designed broadcast products are the result of pooled efforts. That's why EV devoted years to research, by working with network and local broadcasters to engineer all of the desired features into a pair of rather revolutionary new microphones for ENG and EFP.

EV confirmed that field microphones should incorporate low handling noise, resistance to humidity and moisture problems, extreme durability, and the same reliability and level of performance that the industry has become accustomed to expect from EV microphones like the phenomenal 635A and RE20.

Introducing the RE30 and RE34.

Because remotes present a variety of acoustic environments, EV engineered the RE30 with an omnidirectional pickup pattern, and the RE34 with a cardioid pattern. Except for their polar patterns, each model has the same features.

Both the RE30 and RE34 have switchable outputs—either line level or microphone level. No longer will field crews



be stuck without the right signal level. A flick of the recessed switch adjusts the output level, producing instant compatibility without the need for extra equipment or cables. The low distortion line-level amplifier allows direct interface with line-level inputs such as those common on microwave and fiber optic transmitters.

Additionally, the RE30 and RE34 will drive and hold telephone lines*.

*F.C.C. approved interconnect may be required.

Each microphone includes a low-distortion limiter which functions at either output level.

The RE30 and RE34 can be powered by either phantom power or a standard, available anywhere, 9-volt “transistor radio” battery. With both power sources present, the battery becomes a redundancy powering system that instantly and silently takes over if ever required.

An LED, mounted so as to be easily visible to the talent only, serves several important functions...it shows the presence of phantom power, monitors battery condition, and offers the world's first hand-held “tally light” to signal on-air personalities from off-camera.

Get the whole story.

No advertisement can hope to explain all of the features of these incredible new microphones. Complete engineering data sheets describing the many features and benefits of the RE30 and RE34 are available free upon request.

Many Electro-Voice Professional Microphone Dealers can arrange a hands-on trial at no cost to you. For more information please write to: Greg Silsby, Market Development Manager/Professional Markets, Electro-Voice, Inc., 600 Cecil Street, Buchanan, Michigan 49107.

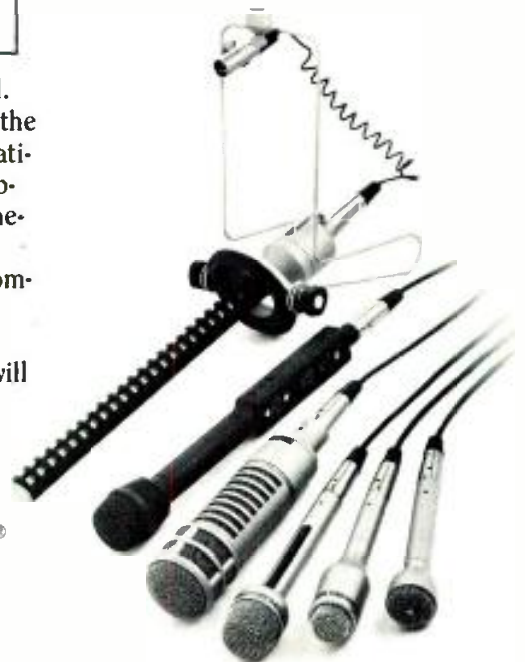

a gulton company

EV Electro-Voice®
SOUND IN ACTION™

Circle 216 on Reader Service Card

Reps/Distributors

GRAY COMMUNICATIONS CONSULTANTS, INC.

Albany
912 883-2121
Doraville
404 455-3121

MILLAR ELECTRONICS, INC.

Atlanta
404 261-6160

RADFORD ASSOC.

Atlanta
404 327-6097

REMTEK, INC.

Dallas, TX
214 387-2855

E.J. RUTH ASSOC.

Birmingham, AL
205 979-0880

TECHNICAL INDUSTRIES, INC.

Atlanta
404 455-7610

TECHNICAL SYSTEMS

Chamblee
404 457-0426

HAWAII

ALOHA ASSOC.

Honolulu
808 941-1574

R.W. CAMPBELL, INC.

Honolulu
808 946-1048

EMC CORP.

Honolulu
808 836-1138

JOHN HARDING CO.

Honolulu
808 836-0941

ISLAND INSTRUMENTS

Ewa Beach
808 689-0671

OMEGA PACIFIC

Honolulu
808 263-4212

IDAHO

DAVIS ASSOC.

Littleton, CO
303 795-1400

DIDIER/DENVER

Evergreen, CO
303 674-6000

D.P.M., INC.

Bellevue, WA
206 747-3309

HALL ELECTRONICS

Boise
208 336-5894

TOPP ENGINEERING SALES CORP.

Bellevue, WA
206 747-5400

WESCOM MARKETING, INC.

Arvada, CO
303 422-7619

ILLINOIS

ALLIED BROADCAST EQUIPMENT

Chicago
312 794-0224

ANCHA ELECTRONICS

Elk Grove Village
312 437-7712

AUDIO RESOURCES, INC.

Westmont
312 655-1180

AVC SYSTEMS, INC.

Elmhurst
312 279-6580

BRIDGEWATER SOUND

Chicago
312 596-0309

CALUMET COMMUNICATIONS

Arlington Heights
312 228-1855

DACOM CORP.

St. Louis, MO
314 436-2800

VICTOR DUNCAN

Chicago
312 943-7300

H.M. DYER ELECTRONICS, INC.

Novi, MI
313 349-7910



Video Delay Lines

ALLEN AVIONICS Video & Pulse Delay Lines replace 75 ohm coaxial cable, provide a more suitable method of achieving precise short delays. The units reduce size, weight, installation costs, save time & effort in making delay changes.

Part No.	Delay Range (Nano-Sec.)	Delay Steps (Nano-Sec.)	Method of Variation	Maximum Insertion Loss @ 100 KHz (db)	Amplitude Flatness At Any Delay Setting 100 KHz to 5.5 MHz (db)	Max. Rise Time (Nano-Sec.)	Package Size (Inches)
VAR005	3-7	Continuous	Trimmer	.20	.2 Max.	N.A.	3 3/8 x 1 1/2 x 1 1/4
VAR011	0-11	Continuous	Trimmer & Toggle	.20	.25	N.A.	4 3/8 x 2 3/8 x 1 1/16
VPO010	0-10.5	5	Toggle	.15	.2	3	4 3/8 x 2 3/8 x 1 1/16
VPO127	0-127	1.0	Toggle	.15	.3	14	4 3/8 x 2 3/8 x 1 1/16
VPO255	0-255	1.0	Toggle	.15	.3	16	4 3/8 x 2 3/8 x 1 1/16
VPO317	0-317.5	2.5	Toggle	.15	.3	20	4 3/8 x 2 3/8 x 1 1/16
VPO635	0-635	5.0	Toggle	*.50	.4	25	4 1/16 x 3 1/16 x 2 1/16
VP1100	0-1100	10.0	Rotary	1.25	.4	30	4 1/16 x 3 1/16 x 2 1/16
VP1270	0-1270	10.0	Toggle	*3.00	.4	30	4 1/16 x 3 1/16 x 2 1/16
VP2075	0-2075	25.0	Toggle	*3.00	.5	40	7 3/8 x 4 1/16 x 2 3/16
VS0315	0-315	5.0	Strap	.25	.4	28	4 x 2 x 1 1/4
VS0635	0-635	5.0	Strap	.60	.5	33	5 x 2 x 1 1/4
VS1275	0-1275	5.0	Strap	1.25	.5	33	5 x 3 x 1 1/4
VS2075	0-2075	25.0	Strap	2.50	.5	40	6 1/2 x 3 1/2 x 2

RACK MOUNTABLE UNITS

VRM0255	0-255	1.0	Slide Switch	.40	.4 Max.	20	1 1/4 x 4 1/8 x 4
VRM0637	0-637.5	2.5	Slide Switch	*1.00	.4	28	1 1/4 x 4 1/8 x 6
VRM1275	0-1275	5.0	Slide Switch	*3.00	.4	33	1 1/4 x 4 1/8 x 9
VRM2270	0-2270	10.0	Slide Switch	*3.00	.5	40	1 1/4 x 4 1/8 x 9
VRS0317	0-317.5	2.5	Strap	.40	.5	26	1 1/4 x 4 1/8 x 4
VRS0635	0-635	5.0	Strap	.75	.5	35	1 1/4 x 4 1/8 x 6
VRS1270	0-1270	10.0	Strap	1.50	.5	37	1 1/4 x 4 1/8 x 9
VRS2260	0-2260	20.0	Strap	3.00	.5	40	1 1/4 x 4 1/8 x 9

*±.2db variation at any delay setting.

Circle 220 on Reader Service Card



RACK MOUNTABLE VIDEO & PULSE DELAY LINES

A complete Rack Mountable series of Video & Pulse Delay Lines, with the capability of replacing up to 1450 feet of cable, is now being marketed by Allen Avionics. (See listing in table at left.)

Impedance: 75 ohms.

Pulse Distortion: Less than 4% with an input pulse rise time of 20 nanoseconds.

Working Voltage: 100 volts maximum. 50 volts maximum for Rack Mountable series.

Return Loss: 20db minimum. 15db minimum for VP2075, VS2075 and Rack Mountable series.

Delay Tolerance: 5% or 1 nanosecond, whichever is greater.

CALL/WRITE

For Video Delay Lines & Filters Catalog

ALLEN AVIONICS, INC.

224 EAST SECOND ST., MINEDLA, NY 11501
Phone: 516-248-8080

Space shuttle image from Hewlett-Packard 45 computer, recorded by LogE/Dunn 631 System

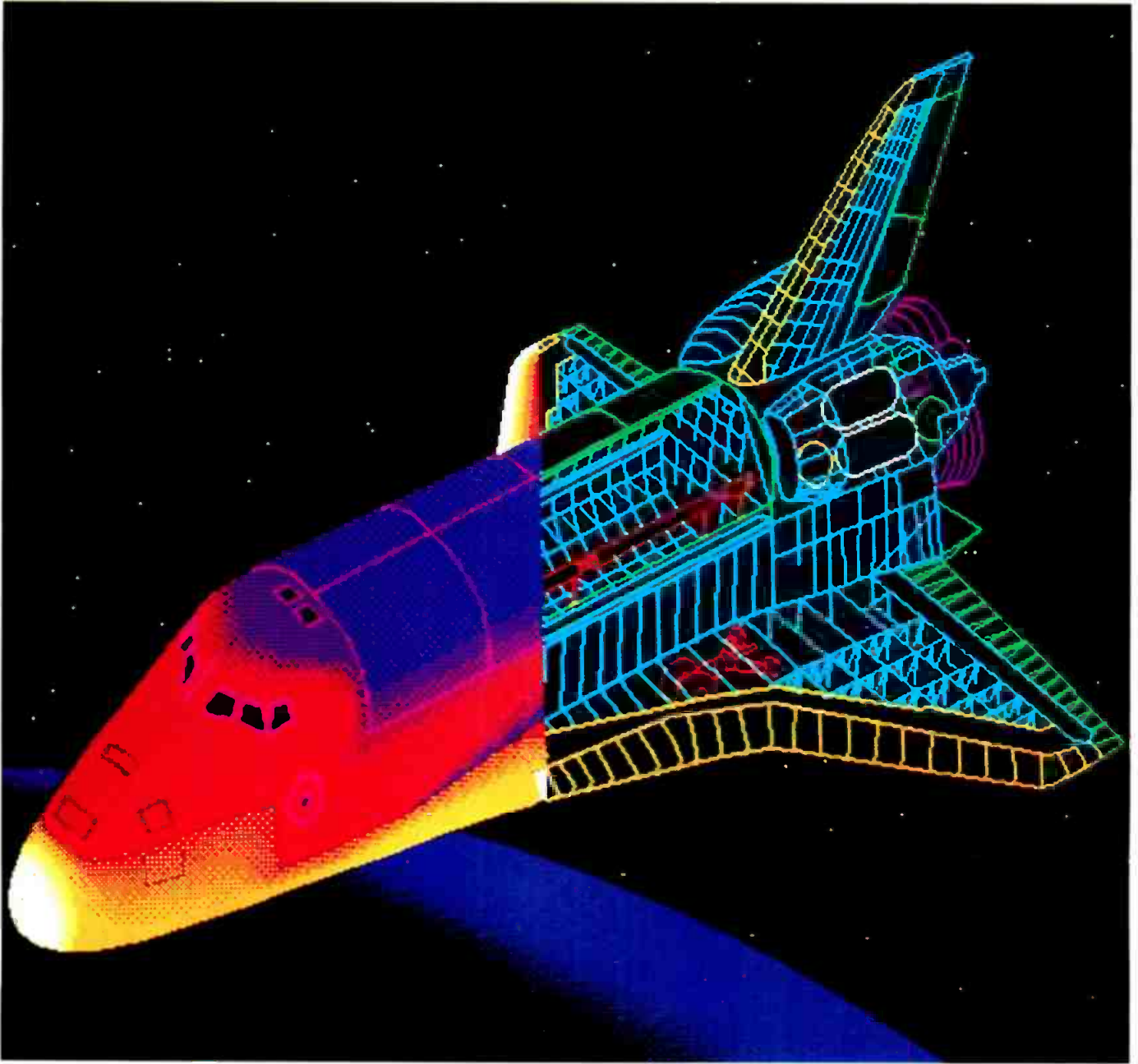

Launching the color graphics recording systems of tomorrow.

Dunn Instruments' line of color graphics film recording systems offer today's... and tomorrow's... highest levels of user-friendliness and versatility in producing high quality photographic output from raster-based computer graphics systems. Note the wide range of camera options, film sizes and types available in these new Dunn systems: **CompactColor**, an 8x10 system with 35mm and Polaroid's Colorgraphic Instant Print and Overhead Transparency System capability. Includes intelligent keyboard for color corrections, enhancements, etc. **VersaColor**, designed for lower-cost 8x10 Ektaflex film. **ProColor**, for pin-registered accuracy in 35mm slide production. Add to these our industry-leading **Model 631**, with standard 8x10 plus our broadest range of camera and film options, and **Model 632**, ideal for 35mm slides, SX-70 and 4x5 Polaroid instant color prints, 16mm cine, and custom film formats. Be sure to watch for **UltraColor**, our soon-to-be-available (4096x4096) resolution system. For complete information on these systems, write or call today!

DUNN
INSTRUMENTS

LogE/Dunn Instruments, Inc.

544 Second St., P.O. Box 77172 • San Francisco, CA 94107
(415) 957-1600 • Telex: 340870

LogEtronics Inc. 7001 Lolsdale Rd., Springfield, Virginia 22150 • LogEtec AG Industriestrasse 57 CH-8152 Glarbrugg, Zurich, Switzerland
LogEtronics GmbH Dieselstrasse 10 6242 Kronberg 2, West Germany

Reps/Distributors

McCURDY RADIO INDUSTRIES, INC.
Elk Grove Village
312 640-7077

MIDTEC ASSOC.
DeSoto, KS
913 441-6565

NOMAD ENGINEERING
Northfield
312 446-2725

PRO AUDIO GENERAL STORE
Carroll Stream
312 231-7120

ROSCOR CORP.
Morton Grove
312 539-7700/312 966-3010

RYAN & ASSOC.
Hawthorne Woods
312 438-2905

STEFFEY MARKETING ASSOC.

Northbrook
312 480-3575

STUDIO-SONICS CORP.
Schaumburg
312 843-7400

SWIDERSKI ELECTRONICS, INC.
Elk Grove Village
312 364-1900

H.M. DYER ELECTRONICS, INC.
Novi, MI
313 349-7910

HOOSIER PHOTO SUPPLIES
Indianapolis
317 875-9000

RYAN & ASSOC.
Hawthorne Woods, IL
312 438-2905

SCIENCE SALES
Ossian
219 622-7383

SOUNDSMITH AUDIO
Indianapolis
317 842-4905

ILLINOIS

ANCHA ELECTRONICS, INC.

189 Gordon Street, Elk Grove Village, IL 60007
(312) 437-7712

AV SYSTEMS AND EQUIPMENT INCLUDING:
Lenco, Microtime, Sony, JVC, Shintron, Dynair, Datatek,
Electrohome, Optel, IPAS, Videotek, Jerrold, Ampex,
Swintek, Altec, Yamaha, Biamp, EV, JBL, Cetec-Vega.

INDIANA

ALLIED BROADCAST EQUIPMENT
Richmond
317 962-8596

CENTURY DYNAMICS, INC.
Fort Wayne
219 486-2681

BRUCE DAWSON & ASSOC.
Indianapolis
317 241-1364
Louisville, KY
502 456-6666

IOWA

EMMONS ASSOC.
Burnsville, MN
612 890-8920

MIDTEC ASSOC.
DeSoto, KS
913 441-6565

FINALLY!

THE WIRELESS LINK

Clear-Com's Wireless Interface Base Station

- is all you need to interface between wired intercoms and remote transceivers
- assures clear, noise-free communications via FM transmission, up to 1/4 mile
- is available in SIMPLEX or FULL DUPLEX models
- Complete Simplex System (one remote), **UNDER \$600**; Complete Full Duplex System (one remote), **UNDER \$700**
- interfaces with Clear-Com and other hardwired intercoms (RTS, Chaos, etc.)
- system includes a Base Station and one or more lightweight, 49mHz remote transceivers with headsets

For more information, call or write:

1111 17th Street • San Francisco, CA 94107
415-861-6666 • TWX: 910-372-1087
EXPORT DIVISION: P.O. Box 302 • Walnut Creek, CA 94596
415-932-8134 • Telex: 176340 CLEAR-COM WNCK

Circle 222 on Reader Service Card

ELECTRO IMPULSE

Thanks You for Making Our
Model DPTC-25KFM Dummy Load
One of our Most Successful Products!



MODEL DPTC-25KFM
Rated 25KW
DC-110MHz
VSWR 1.15:1
Useable to 200MHz

Load is Dry,
Forced Air Cooled,
Fully Interlocked and
WARRANTED FOR 25 MONTHS

Our New General Catalog 892 is now available upon request covering:

- Dummy Loads • Baluns • Calorimeters
- Power Meters/Attenuators

EXCELLENCE IN ENGINEERING
Electro IMPULSE, INC.

SINCE 1949

116 Chestnut St., Red Bank, N.J. 07701
Telephone: 201-741-0404

Circle 223 on Reader Service Card



VSWR of 1.1:1
for approximately
500kHz

Lower Q
than ever before

Massive 3 1/8 inch two tube
balun provides wider match
bandwidth than loop
coupled designs

Two and one half times
the bandwidth of standard
circularly polarized low power
and high power antennas

All elements fed inphase to
produce maximum gain
on the horizon

5 Points To Check Before You Buy Your Next Circularly Polarized FM Broadcast Antenna.

Make sure it's from Phelps Dodge. Make sure it's super powered. We have a series of three from which to choose: A single element with a 3 1/8 inch fine matcher, an end fed two element array with a 6 1/8 inch fine matcher and a center fed four element array with a 6 1/8 inch fine matcher. They're all precisely cut and matched at the factory. Stainless steel internal deicer heaters are available, too. Element input impedance is carefully adjusted. Can we tell you more? Write, call or TWX today for literature and prices: Phelps Dodge Communications Company, Route 79, Marlboro, NJ 07746, (201) 462-1880, TWX: 710-722-3861.

**phelps
dodge**
Communications Company
DIVISION OF PHELPS DODGE INDUSTRIES, INC.

Reps/Distributors

RANCILIO ASSOC., INC.
Council Bluffs
712 323-8218

KANSAS

B.C. ELECTRONICS SALES, INC.
Kansas City
316 942-9840

DACOM CORP.
St. Louis, MO
314 436-2800

DIDIER/DENVER
Evergreen, Co
303 674-6000

LINES VIDEO SYSTEMS
Springfield, MO
417 862-5533

MIDTEC ASSOC.
DeSoto
913 441-6565

RM ASSOC., INC.
Shawnee Mission
913 631-7606

KENTUCKY

BRUCE DAWSON & ASSOC.

Indianapolis, IN
317 241-1364
Louisville
502 456-6666

RALPH HUCABY
Nashville, TN
615 373-0231

MIDWEST CORP.
Edgewood
606 331-8990

SCIENCE SALES
Ossian, IN
219 622-7383

W.K.M. ASSOC.
Pittsburgh, PA
412 892-2953

LOUISIANA

DUSTY ARNOLD
Richardson, TX
214 644-7607

AUDIO MEDIA ASSOCIATION
New Orleans
504 586-0140

FOGARTY ENGINEERING SALES CO.
Baton Rouge

504 928-3372
Harvey
504 366-3264

GIESLER BROADCASTING SUPPLY
Houston, TX
713 774-3314

MZB & ASSOC.
Dallas, TX
214 233-5535

PARCOM
Southlake, TX
817 481-7221

REEL PRODUCTIONS
Shreveport
318 227-1200

REMTEK, INC.
Dallas, TX
214 387-2855

MAINE

ABBOTT ALLISON CO., INC.
Meriden, CT
203 237-9232

BARTLETT ASSOC.
White Plains, NY
914 949-6476

HOLZBERG ASSOC.
Totowa, NJ
201 256-0455

KENTROL
Waterville
603 424-5677
201 872-6458

VIDEO SYSTEMS, INC.
Houston, TX
713 686-9651

MARYLAND

BARTLETT ASSOC.
White Plains, NY
914 949-6476

CTL COMMUNICATIONS
Silver Springs
202 585-6311

R.J. MARKETING LTD.
Rockville
301 251-0330

MYER-EMCO
Rockville
301 468-2000

PIERCE-PHELPS
Rockville
301 984-7979

PROFESSIONAL PRODUCTS
Bethesda
301 657-2141

RECORDING CONSULTANTS, INC.
Silver Springs
302 537-1800

WASHINGTON MUSIC
Wheaton
301 946-8808

WILTRONIX, INC.
Washington Grove
301 258-7676

MASSACHUSETTS

ABBOT ALLISON CO., INC.
Meriden, CT
203 237-9232

APPLIED MEASUREMENTS, INC.
Acton
617 263-2766/617 646-7250

BARTLETT ASSOC.
White Plains, NY
914 949-6476

CRAMER AUDIO/VIDEO SYSTEMS
Needham Heights
617 449-2100

RICHARD DEAN ASSOC., INC.
Newburyport
617 462-1150

HOLZBERG ASSOC.
Totowa, NJ
201 256-0455

LAKE SYSTEMS CORP.
Newton
617 244-6881

LANDY ASSOCIATES, INC.
Framingham, MA
617 877-9570

BILL McFADDEN
Annisquam
617 283-7507

PROFESSIONAL RECORDING & SOUND, INC.
Boston
617 254-2110

SHEA SALES
Framingham
617 875-4199

V.F. SALES, INC.
Natick
617 237-6544

LOUISIANA

GIESLER BROADCASTING SUPPLY, INC.

5914 Maple, Houston, TX 77074
(713) 774-3314

Professional advice, service, experience. Full line of RF & audio equipment. Offering transmitters through srylii. Call Bernie at (713) 774-3314.

MASSACHUSETTS

Landy Associates, Inc.

Systems Design, Installation and Service Featuring Ikegami Cameras & Monitors, Anton-Bauer Batteries, BMS, Inc. (Microwave), Crown, Datatek, JBL, Peter Lisand, Panasonic, JVC, Skotel, Tektronix, Videotek, Leader and all of the finest in Broadcast, Production, and Recording Equipment.

Jim Landy, 1890 E. Marlton Pike,
Cherry Hill, N.J. 08003—609-424-4660
Brad Reed, 801 Water Street,
Framingham, MA 01701—617-877-9570

NEW!

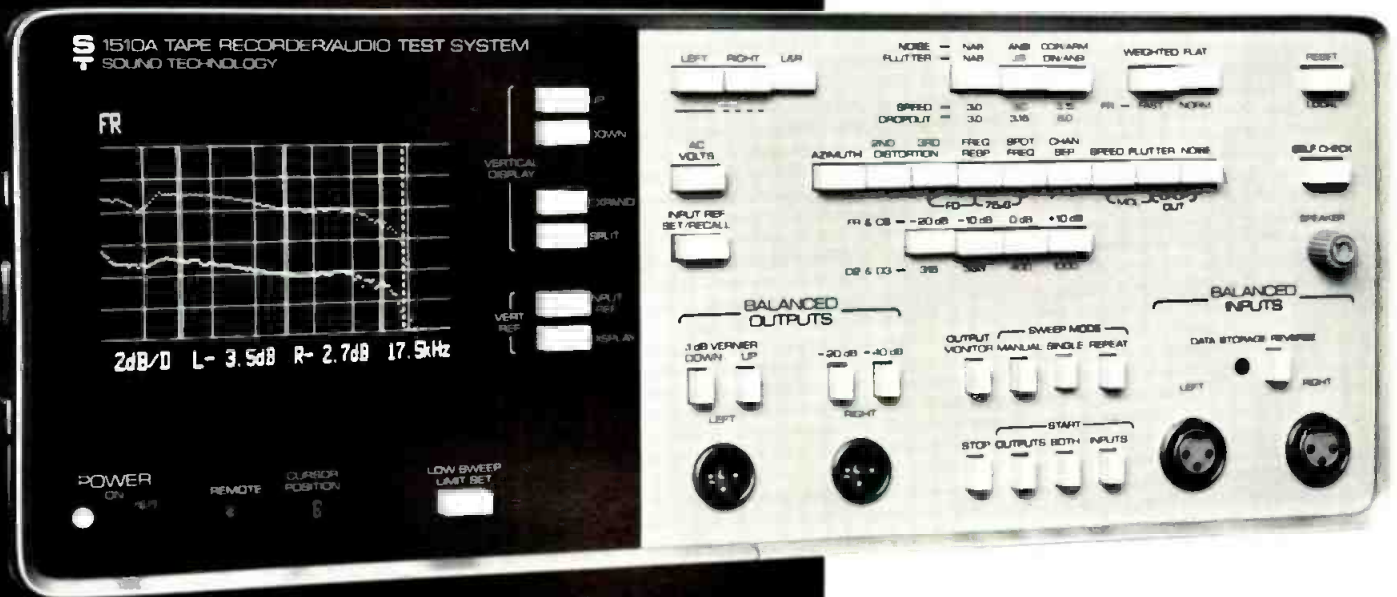

The Sound Tech 1510A ... the most advanced audio measurement system available today.

- 2nd and 3rd Harmonic distortion vs. level
- Spectral and composite noise
- Dynamic range vs. frequency
- Wow and Flutter
- Delta speed and drift
- Compression ratio
- Dropout vs. time

TV AUDIO GOING STEREO?

The 1510A is the only two-channel test instrument available today. When the FCC decides on a TV stereo system, the 1510A will be ready to go to work for you.

WHAT ABOUT AUTOMATION?

With the addition of the General Purpose Interface Bus, the 1510A can be run using a computer. Testing time is cut down to seconds rather than minutes. Using the bus, the engineer can set up a regular equipment maintenance schedule.

CALL SOUND TECHNOLOGY TODAY!

We'll be pleased to send full information on the 1510A and our other industry standard test equipment. Or, for immediate action, call (408) 378-6540.

S SOUND
T TECHNOLOGY

1400 DELL AVENUE
CAMPBELL, CALIFORNIA 95008
Telephone: (408) 378-6540
Telex: 357445

WHY?

Because one 1510A can do in minutes what used to take hours with more conventional and ordinary test set-ups, and at a price you can afford. It can also show you test results you've never seen before. Designed around the most advanced microprocessor hardware, the 1510A incorporates all the necessary on-board software programs to get the job done: you don't need to waste time and money writing programs.

DESIGNED FOR THE BROADCASTER

The Sound Technology 1510A features differential inputs, electronically balanced outputs with a clean low-distortion signal (typically 003%) from +30 dBm to -70 dBm.

WHAT WILL THE 1510A DO?

Here's a small sample of the varied jobs the 1510A will perform for you:

- Exclusive asynchronous inputs and outputs for remote location

- testing (satellite, transmitter, studios)
- Total tape recorder and cart machine mechanical and electronic checks
- Transmission line analysis
- Automated production testing using GPIB option
- One-third octave spectral analysis of noise
- Verify mixing console performance
- Evaluation of audio quality for VTR's
- Verify threshold points on compressor/limiters using compression ratio test
- Thoroughly evaluate and certify magnetic film and audio tape
- Complete reference turntable and phono cartridge analysis

FOURTEEN COMPREHENSIVE AUDIO TESTS

Here are some of the tests you can run with the 1510A:

- Frequency Response; ± 0.1 dB
- Channel Separation
- Autoranging AC Volts
- Phasing

Reps/Distributors

MICHIGAN

AUDIO BROADCAST GROUP, INC.

Grand Rapids
616 452-1596

AUDIO MARKETING CONCEPTS

Ann Arbor
313 663-9733

C.M. SALES

West Bloomfield
313 626-2397

COMPLETE COMMUNICATIONS

Southfield
313 642-0456

VICTOR DUNCAN

Madison Heights
313 589-1900

H.M. DYER ELECTRONICS, INC.

Novi
313 349-7910

HY JAMES ENTERPRISES

Farmington Hills
313 471-0027

RILEY & PETCHELL SALES, INC.

Detroit
313 937-3000

RYAN & ASSOC.

Hawthorne Woods, IL
312 438-2905

SCIENCE SALES

Ossian, IN
219 622-7383

THIBODEAU ENGINEERING

Birmingham
313 642-6620

W.K.M. ASSOC.

Pittsburgh, PA
412 892-2953

MINNESOTA

AINSLIE CO.

Edina
612 920-2996

AVC SYSTEMS, INC.

Minneapolis
612 729-8305

EMMONS ASSOC.

Burnsville
612 890-8920

KNOX ASSOC., INC.

St. Paul
612 488-4502

TODD COMMUNICATIONS

Minneapolis
612 941-0556

YORE CO.

White Bear Lake
612 770-9760

MISSISSIPPI

EME II, INC.

Decatur, GA
404 325-0165

RALPH HUCABY

Nashville, TN
615 373-0231

REMTEK, INC.

Dallas, TX
214 387-2855

E.J. RUTH ASSOC.

Birmingham, AL
205 979-0880

MISSOURI

ANTECH LABS

St. Louis
314 997-5666

DACOM CORP.

St. Louis
314 436-2800

H.M. DYER ELECTRONICS, INC.

Novi, MI
313 349-7910

ELECTRO MECHANICAL ASSOC., INC.

Bridgeton
314 291-7661

LINES VIDEO SYSTEMS

Springfield
417 862-5533

MIDTEC ASSOC.

DeSoto, KS
913 441-6565

NZ VIDEO SYSTEMS

Sikeston
314 471-7145

RANCILIO ASSOC., INC.

St. Louis
314 631-3326

RM ASSOC. LTD.

St. Louis
314 225-8488

SOUNDWERKS/MICAR

Kansas City
816 842-4002

VMI

St. Louis
314 569-1334

MONTANA

DIDIER/DENVER

Evergreen, CO
303 674-6000

HALL ELECTRONICS

Boise, ID
208 336-5894

NEBRASKA

DIDIER/DENVER

Evergreen, CO
303 674-6000

LINES VIDEO SYSTEMS

Springfield, MO
417 862-5533

MIDTEC ASSOC.

DeSoto, KS
913 441-6565

NEVADA

BROADCAST MARKETING ASSOC.

San Jose, CA
408 946-2236

MARCOM

Scotts Valley, CA
408 438-4273

RDX CORP.

Pasadena, CA
213 681-3451

NEW HAMPSHIRE

ABBOTT ALLISON CO., INC.

Meriden, CT
203 237-9232

BARTLETT ASSOC.

White Plains, NY
914 949-6476

HOLZBERG ASSOC.

Totowa, NJ
201 256-0455

NEW JERSEY

A.F. ASSOC.

Northvale
201 767-1000

JOHN B. ANTHONY CO.

Cedar Grove
201 857-2426

BARTLETT ASSOC.

White Plains, NY
914 949-6476

CINECRAFT

Moonachie
201 939-0875

FRIEDMAN ASSOC.

Union
201 964-6200

HOLZBERG ASSOC.

Totowa
201 256-0455

LANDY ASSOC.

Cherry Hill
609 424-4660

METROREP SALES, INC.

Freehold
201 462-1221

NEW BREED ASSOC.

Edison
201 225-0085

SHEA SALES

Maplewood
201 762-2382

USCADA EXPORTS, INC.

Tabor
201 625-3887

MINNESOTA

TODD COMMUNICATIONS, INC.

6545 Cecilia Circle, Minneapolis, MN 55435
(612) 941-0556

Serving Upper Midwest-Video Systems Design, Installation & Service. Video line includes: Ikegami, Utah Scientific, Lenco, Ross Video, HVS. RF Systems Consulting, Design, Installation: TV Translators, Microwave, Cable TV, Low Power TV.

DELTA BROADCAST PRODUCTS

AMC-1



The **Amplitude Modulation Controller** is the only modulation controlling system that provides a completely closed loop around the transmitter. The sampling of actual modulation levels after the PA output network assures precise adjustment for optimum modulation levels. The AMC-1 also keeps a digital count of positive and negative overmodulation bursts for both present and previous one minute periods.

APC-1



The **Automatic Power Controller** is your insurance against citations for over- and under-power operation. The APC-1 continuously monitors the transmitter output power, and makes automatic power adjustments with the transmitter loading control. This assures proper power adjustment at all times.

OIB-1



OIB-3

The **Operating Impedance Bridge** measures the impedance of networks, radiators, and the like while they operate under full power. VSWR as well as complex impedances of up to $400 \pm j300$ ohms can be measured.

The **OIB-3 Operating Impedance Bridge** provides extended resistance and reactance ranges, measuring up to $1000 \pm j900$ ohms. The bridge has a built-in carrying case and RF amplifier for improved nulling.

DAM-1



The **Digital Antenna Monitor** couples pushbutton ease of operation with digital accuracy. The DAM-1 will accept RF samples from up to 12 towers (with an auxiliary panel) and features $\pm 1^\circ$ phase and $\pm 2\%$ current ratio accuracies. Remote panels and other accessories are available.

6730-E
6740-B



Designed to switch two transmitters from antenna to dummy load, the 6730E interfaces with 1 5/8 inch coaxial cable. For 3 1/8" lines, the 6740-B transfer switch is used. Either manually or remote controlled, the Transfer Switch is fully interlocked and can be wired to existing equipment to prevent "hot" switching.

AAM-1



The **Analog Antenna Monitor** gives stable phase and ratio readings even in high RF fields. Separate phase and ratio mirrored-scale meters assure accurate meter indications.

TCA



State of the art antenna current metering has arrived in the TCA Ammeter Systems. Accurate, Modulation-free, temperature stable current indications are found in the TCA. Models include single and dual scale meters.

RG-3



The **Receiver/Generator** combines a two-watt RF output and a correlation detector circuit that virtually eliminates interference problems. The RG-3 can be used in conjunction with any conventional impedance bridge including the OIB series.

RCS-1V



The **RCS-1V Remote Control System** combines microprocessor technology with simplified operation. Features include direct interface boards for antenna monitors, patented remote modulation bargraph, automatic logging, and synthesized speech telephone interface. The modular design allows the customer to plug in additional input or control boards to expand remote control capabilities even after the system is operating in the field.

TCT



Delta's **Toroidal Current Transformers** provide accurate sampling current and phase values without the problems associated with sampling loops. Three output voltage ranges are available, as well as high voltage models for high-power facilities.

CPB-1



The **Common Point Impedance Bridge** is designed for permanent installation; and allows continuous monitoring of the common point, thus facilitating network adjustment. This model can be provided with one of Delta's TCA ammeters mounted in the front panel.

DELTA ELECTRONICS



5730 GENERAL WASHINGTON DRIVE
P.O. Box 11268 • ALEXANDRIA, VIRGINIA 22312
TELEPHONE: 703-354-3350 TWX: 710-832-0273
Circle 225 on Reader Service Card

Reps/Distributors

NEW MEXICO

DIDIER/DENVER

Evergreen, CO
303 674-6000

HEWITT & ASSOC., INC.

Albuquerque
505 299-7746

INDUSTRIAL PRODUCTS CORP.

Albuquerque
505 256-3561

NEW YORK

ABEKAS VIDEO SYSTEMS, INC.

Douglaston
212 224-7387

JOHN B. ANTHONY CO.

New York
212 585-2027

ARGIL INTERNATIONAL LTD.

New York
212 691-2133

AUDIOTECHNIQUES

New York
212 586-5989

BARTLETT ASSOC.

White Plains
914 949-6476

THE CAMERA MART

New York
212 757-6977

DARMSTEDTER ASSOC., INC.

Baldwinsville
315 638-1261

PETER DECEW AGENCY

Cazenovia
315 655-8602

FERCO

New York
212 245-4800

FRIEDMAN ASSOC.

Union, NJ
201 964-6200

HOLZBERG ASSOC.

Totowa, NJ
201 256-0455

MARTIN AUDIO VIDEO CORP.

New York
212 541-5900

L. MATTHEW MILLER ASSOC.

New York
212 741-8011

MPCS

New York
212 586-3690

NORTHEAST BROADCAST LABS, INC.

South Glens Falls
518 793-2181

PULEO ELECTRONICS, INC.

Lynbrook
516 599-4875

SONOCRAFT

New York
212 760-9300

TERRYBERRY SALES

Williamsville
716 632-7404

WESTEC AUDIO VIDEO, INC.

New York
212 586-1662

WORLDTRONICS TRADING CO., INC.

Plainview
516 822-9021

NORTH CAROLINA

BARTLETT ASSOC.

White Plains, NY
914 949-6476

BROADCAST SERVICES CO.

Rour Oaks
919 934-6869

DOUG COOK & ASSOC., INC.

Charlotte
704 542-6510

EME I, INC.

High Point
919 869-3335

27% SCA Utilization means 73% Opportunity from the NEW SUBSIDIARY COMMUNICATION AUTHORIZATION CHANGES

Only 27% of the FM broadcasters utilize SCA presently. The FCC now allows FM stations to carry a "second sub-channel." In fact almost anything that can be transmitted will now be allowed. This additional channel opens up new communication and information possibilities...new profits...new subsidiary businesses. By using these additional FM signals instead of costly telephone lines, the price of communicating becomes less expensive.

Together let's determine how you take advantage of these new changes. Johnson's R & D laboratory and manufacturing facility is ready to apply 30 years of FM-SCA-Know-How to your needs. Start the action — call or write for our booklet, that explains how SCA impacts your corporate future by increasing your corporate profits.

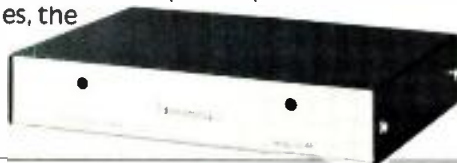

16 Page Booklet explains SCA...rule changes...gives case histories of successful sub-carrier users...outlines potential for many industries...helps you determine if SCA can benefit your company. Write or call Joseph Lutz, President 305-339-2111



johnson
electronics, inc.

62 South US 17-92 • Casselberry, Florida 32707

Circle 227 on Reader Service Card

CAMERA SALE!



MINT CONDITION!

11 Triax Hitachi SK96's, currently in use on NEP Supershooters II&III.

RTS intercom, remote senior video, handheld breakdown kits, big lenses

Chet Sawicki
(717) 826-1616

Circle 228 on Reader Service Card

The new Saticon II camera tube. Clearly superior to lead oxide.

Compare the unretouched photos below and see for yourself how the new RCA Saticon* II camera tube reduces specular high-light memory, without red trail.

You no longer have to choose between lead oxide's good handling of highlights and Saticon's well known superiority in other critical performance factors. Now it's a whole new ball game.

Computer-aided deposition and advanced material purification technologies have given Saticon II a considerably improved photoconductor. Your benefits: less highlight trail, reduced highlight memory (as much as 75% less than that experienced with earlier Saticon tubes), improved resistance to image burn.

What's more, you still get all of the recognized advantages of Saticon: high resolution,

distortion-free colors, very low lag, and extremely long tube life. And Saticon II is backed by a warranty that's second to none. RCA offers full replacement for any failure in normal use for six months, compared with only two months for Plumbicon™.

Your choice is now clear. For more information on the complete Saticon line, contact your RCA distributor or write to RCA Camera Tube Marketing, New Holland Avenue, Lancaster, PA 17603. Or call (800) 233-0155. In Penna., phone collect to (717) 397-7661. Overseas, contact RCA Brussels, Belgium. Sao Paulo, Brazil. Sunbury-on-Thames, Middlesex, England. Paris, France. Munich, W. Germany. Hong Kong. Mexico 16 DF, Mexico.

*Used by permission of trade mark owner.



Good. Plumbicon XQ1427.

Photograph of direct reflection of flood lamps, produced by camera with CTS circuitry. Note highlight memory with red trail.



Better. Saticon II BC4390.

Same subject and conditions as in photograph at left. Note reduced highlight memory without red trail.



RCA

Circle 226 on Reader Service Card

www.americanradiohistory.com

Reps/Distributors

EME IV, INC.
Williamsburg, VA
804 253-0171

F.M. ASSOC., INC.
Ramseur
919 824-2196
919 824-8261

**SOUTHERN COASTAL
MARKETING
SERVICES, INC.**
Charlotte
704 542-6543
Pineville
704 889-4508

STUDIO WORKS
Charlotte
704 375-1053

**TECHNICAL VIDEO
SYSTEMS, INC.**
Winston-Salem
919 748-0916

NORTH DAKOTA

AINSLIE CO.
Edina, MN
612 920-2996

EMMONS ASSOC.
Burnsville, MN
612 890-8920

OHIO

**WALTER BRAUER &
ASSOC., INC.**
Dayton
513 277-4957
Wickliffe
216 943-0601

**CAMBRIDGE
MARKETING GROUP, INC.**
Westerville
614 890-7788

BRUCE DAWSON & ASSOC.
Indianapolis, IN
317 241-1364
Louisville, KY
502 456-6666

**H.M. DYER
ELECTRONICS, INC.**
Novi, MI
313 349-7910

KAVCO, INC.
Dayton
513 898-2003

MIDWEST CORP.
Columbus
614 476-2800
Cincinnati
513 651-1904

**C.L. PUGH &
ASSOCIATES, INC.**
Columbus
614 486-9678

SCIENCE SALES
Ossian, IN
219 622-7383

BOB WHITE ASSOC.
Solon
216 248-1317

W.K.M. ASSOC.
Pittsburgh, PA
412 892-2953

OKLAHOMA

DUSTY ARNOLD
Richardson, TX
214 644-7607

WALTER BREWER
Tulsa
918 749-9894

**DOUG BROWN
ENTERPRISES, INC.**
Tulsa
918 747-3618

MZB & ASSOC.
Dallas, TX
214 233-5535

PARCOM
Southlake, TX
817 481-7221

RADCOM INC.
Eureka Springs
501 253-8556

REMTEK INC.
Dallas, TX
214 387-2855

OREGON

D.P.M. INC.
Bellevue, WA
206 747-3309

MARCOM
Seattle, WA
206 722-2636

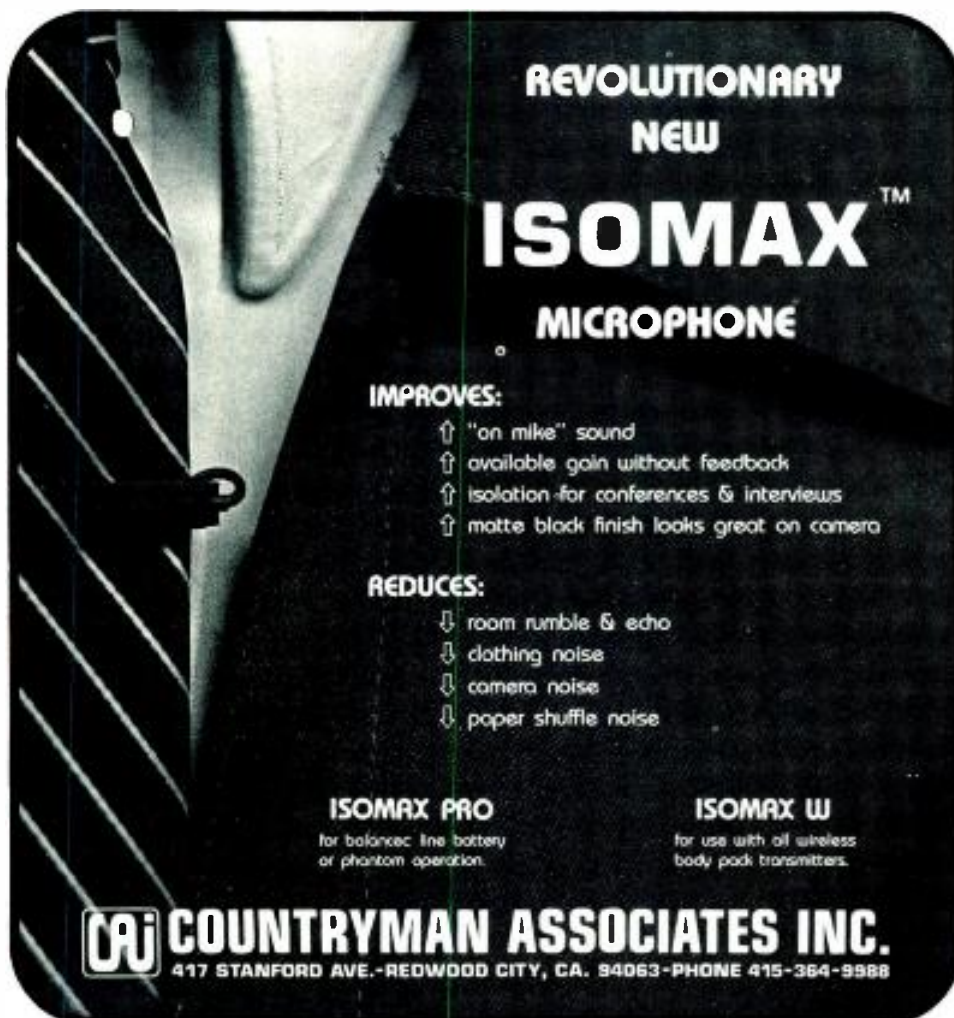

**REVOLUTIONARY
NEW**

**ISOMAX™
MICROPHONE**

IMPROVES:

- ↑ "on mike" sound
- ↑ available gain without feedback
- ↑ isolation for conferences & interviews
- ↑ matte black finish looks great on camera

REDUCES:

- ↓ room rumble & echo
- ↓ clothing noise
- ↓ camera noise
- ↓ paper shuffle noise

ISOMAX PRO
for balanced line battery
or phantom operation.

ISOMAX W
for use with all wireless
body pack transmitters.

CAJ COUNTRYMAN ASSOCIATES INC.
417 STANFORD AVE.-REDWOOD CITY, CA. 94063-PHONE 415-364-9588

Circle 230 on Reader Service Card

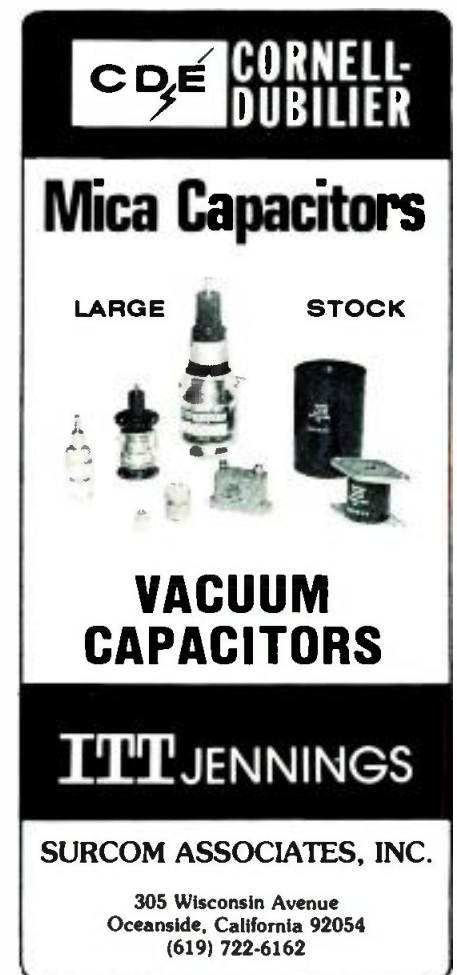

**CDE CORNELL
DUBILIER**

Mica Capacitors

LARGE STOCK

**VACUUM
CAPACITORS**

ITT JENNINGS

SURCOM ASSOCIATES, INC.

305 Wisconsin Avenue
Oceanside, California 92054
(619) 722-6162

Circle 231 on Reader Service Card

Series 800

just imagine...SFX video power plus...

- + Dual Chroma Keyers + Dual Luminance Keyers
- + Dual Matte Key Generators + Dual Key Borders
- + Super wide, SuperSoft borders
- + CAP, Computer Assisted Production
- + FlexiKey... Central Dynamics' new, powerful Digital Video Effects at a fraction of the cost... manipulates titles, logos and images with spin, flip, rotation, zoom, compression or any combination of these effects.

All this power is surprisingly affordable... the Series 80's modular, proven design assures fast

delivery and there is a model to meet any post-production and live programming requirement.

480. *Compact versatility...*
4 buses with the SFX Power+ system.

680. *Exceptional big studio performance...* 6 buses with the SFX Power+ system and the new Series 80 Program Processor.

1080. *The ultimate switcher* for the most sophisticated productions... 10 buses with 2 SFX Power+ systems and the new Series 80 Program Processor.

Call or write for complete details:



CENTRAL DYNAMICS

Central Dynamics, 401 Wynn Drive, Huntsville, AL 35805 (205) 837-5180
New York: (914) 592-5440, Chicago: (312) 991-4720, Los Angeles: (213) 766-8185
Montreal: 147 Hymus Blvd., H9R 1G1 (514) 697-0810, Toronto (416) 446-1543
Circle 229 on Reader Service Card

Reps/Distributors

NU-COM ASSOC., INC.
Seattle, WA
206 364-9911

AUDIO ASSOC. INC.
Bethlehem
215 865-6013

HOLZBERG ASSOC.
Totowa, NJ
201 256-0455

SIGNAL MARKETING, INC.
Devon
215 964-0606

**TOPP ENGINEERING
SALES CORP.**
Bellevue, WA
206 747-5400

BARTLETT ASSOC.
White Plains, NY
914 949-6476

**LARRY ASSOCIATES,
INC.**
Cherry Hill, NJ
609 424-4660

TEKCOM CORP.
Philadelphia
215 627-6700

PENNSYLVANIA

**CAMBRIDGE
MARKETING GROUP, INC.**
Pittsburgh
412 653-7718

**LERRO ELECTRICAL
CORP.**
Philadelphia
215 223-8200

WARREN RADIO CO.
Erie
814 454-5285

**ALPHA VIDEO &
ELECTRONICS CO.**
Carnegie
412 923-2070

KENN EBERT
Downingtown
215 269-5898

**MULTI-
MEASUREMENTS, INC.**
Warminster
215 675-3082

WILTRONIX, INC.
Washington Grove, MD
301 258-7676

W.K.M. ASSOC.
Pittsburgh
412 892-2953

PENNSYLVANIA

Landy & Associates, Inc.

Systems Design, Installation and Service Featuring Ikegami Cameras & Monitors, Anton-Bauer Batteries, BMS, Inc. (Microwave), Crown, Datatek, JBL, Peter Lisand, Panasonic, JVC, Skotel, Tektronix, Videotek, Leader and all of the finest in Broadcast, Production, and Recording Equipment.

**Jim Landy, 1890 E. Marlton Pike,
Cherry Hill, N.J. 08003—609-424-4660**
**Brad Reed, 801 Water Street,
Framingham, MA 01701—617-877-9570**

PIERCE PHELPS, INC.
Philadelphia
215 879-7171

PROCESSING PLUS, INC.
Allentown
800 523-9396

PRO COM SYSTEMS
Pittsburgh
412 471-6220

**RADIO SYSTEMS DESIGN,
INC.**
Edgemont
215 356-4700

RHODE ISLAND

**ABBOTT ALLISON CO.,
INC.**
Meriden, CT
203 237-9232

BARTLETT ASSOC.
White Plains, NY
914 949-6476

HOLZBERG ASSOC.
Totowa, NJ
201 256-0455



Inovonics Model 500 Acoustic Analyzer

It's everything you need for fast, accurate one-third-octave sound-level and reverberation-time analysis... all in one easy-to-use package.

- Weighted or un-weighted SPL analysis
- Automatic or manual reference-level adjustment

- Digital display of RT₆₀ with decay characteristic plotted on screen
- Built-in pink-noise generator
- Rear-panel connectors for external oscilloscope and digital peripherals
- AC and battery operation

Inovonics' Model 500 Acoustic Analyzer. The sound choice for analysis at the airport, auditorium, or laboratory. For all the details, call or write us today.

Inovonics Inc.

503-B Vandell Way
Campbell, CA 95008
(408) 374-8300



Circle 233 on Reader Service Card

NEW Continental FM Exciter

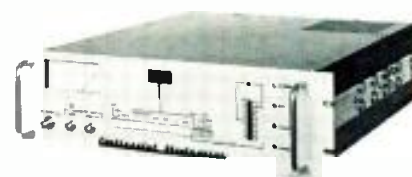

The ultimate FM Exciter. The Type 802A solid-state exciter offers broadcasters unmatched performance. Modulation exceeds all currently marketed FM exciters; no tuning adjustments required; exciter may be used as low power transmitter, with output of 50 watts into 50 ohm load at all FM frequencies.

Write for brochure on 802A FM Exciter
Continental Electronics Mfg. Co.
Box 270879 Dallas, Texas 75227
Phone (214) 381-7161

*Continental
Electronics* 

1 kW thru 50 kW AM & FM transmitters and related equipment
©1983 Continental Electronics Mfg. Co. 5329

Circle 234 on Reader Service Card

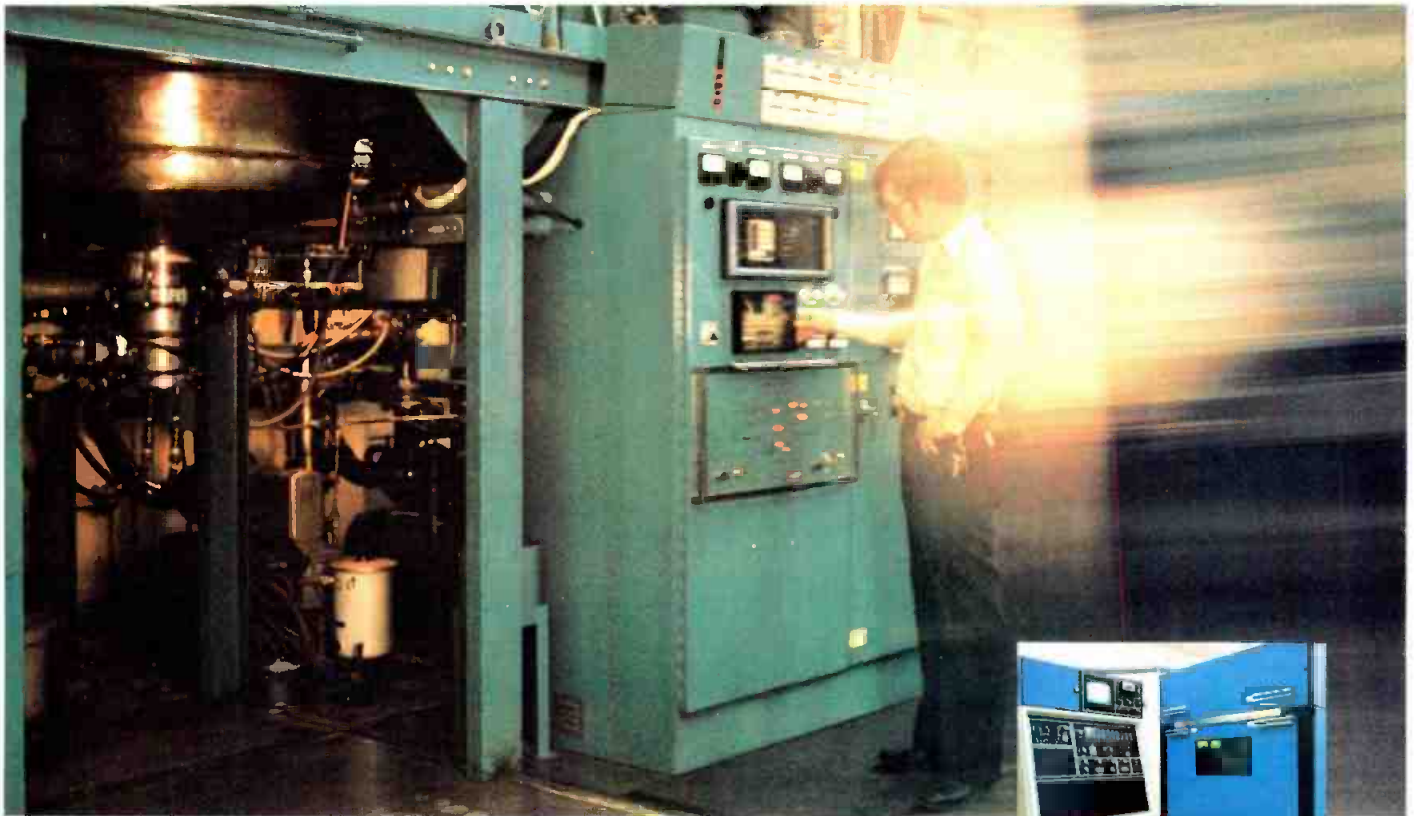

EIMAC—moving toward higher frequency and performance in the 1980s.

Varian EIMAC, the world's leading power grid tube manufacturer, proves its expertise with almost 50 years of know-how in state-of-the-art manufacturing techniques.

Continuing in its tradition of providing customers with maximum operating frequency and high gain, EIMAC designs and manufactures superior tubes for broadcast service.

Close tolerance control and modern manufacturing techniques provide improved life and uniform performance, tube after tube.

Consider the new EIMAC 4CX40,000G. This 40 kW tube is full-power rated to 220 MHz. The tube features laser-cut, high sta-

bility Pyrolytic graphite grids and a new internal structure combining low RF losses and high operating efficiency.

For more information on Varian EIMAC tubes and high power VHF cavity amplifiers, call or

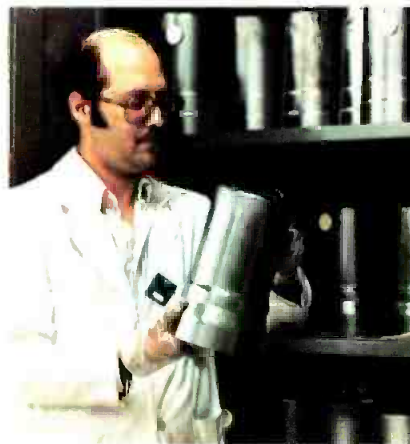

write today. Or contact the nearest Varian Electron Device Group sales office.

Varian EIMAC
301 Industrial Way
San Carlos, California 94070
415 • 592-1221

Varian AG
Grienbachstrasse 17
Post Fach
CH-6300 Zug, Switzerland
Tel: (042) 31 66 55
Telex: 845-78789



Reps/Distributors

SOUTH CAROLINA

EME I, INC.
High Point, NC
919 869-3335

EME IV, INC.
Williamsburg, VA
804 253-0171

REMTEK, INC.
Dallas, TX
214 387-2855

SOUTH DAKOTA

AINSLIE CO.
Edina, MN
612 920-2996

EMMONS ASSOC.
Burnsville, MN
612 890-8920

TENNESSEE

BROADCAST EQUIPMENT & SUPPLY CO.
Bristol
615 878-2531

EME II, INC.
Decatur, GA
404 325-0165

RALPH HUCABY
Nashville
615 373-0231

PHASE AUDIO, INC.
Memphis
901 726-1900

REMTEK, INC.
Dallas, TX
214 387-2855

E.J. RUTH ASSOC.
Birmingham, AL
205 979-0880

VALLEY AUDIO
Nashville
615 383-4732

WILSON AUDIO SALES
Nashville
615 794-0155

TEXAS

ABADON/SUN, INC.
San Antonio
512 824-8781

ALLIED BROADCAST EQUIPMENT
Plano
214 423-8667

DUSTY ARNOLD
Richardson
214 644-7607

DICK BELLEW SALES, INC.
Dallas
214 373-4590

BROADCAST SYSTEMS, INC.
Austin
512 836-6014

CONTINENTAL ELECTRONICS MFG. CO.
Dallas
214 381-7161

DIDIER/DENVER
Evergreen, CO
303 674-6000

DOBBS-STANFORD CORP.
Dallas
214 358-0800

VICTOR DUNCAN
Dallas
214 869-0200
Irving
214 869-0200

ELECTRO SYSTEMS ENGINEERING
Dallas
214 343-0764

GIESLER BROADCASTING SUPPLY, INC.
Houston
713 774-3314

LINROSE ELECTRONICS
San Antonio
512 342-8849

MAGNETIC MEDIA
Houston
512 451-0138

DUKE McLANE
Dallas
214 247-5999

MIDCOM
Arlington
817 461-2211

MZB & ASSOC.
Dallas
214 233-5535

PARCOM
Southlake
817 481-7221

REMTEK, INC.
Dallas
214 387-2855

BUCK ROGERS & ASSOC.
McAllen
512 682-0398

SAVCO
Richardson
214 234-1841

SOUTHWEST PRO AUDIO
Austin
512 443-4567

TAFT BROADCASTING CORP.
Houston
713 622-1724

TENICKI & ASSOC.
Dallas
214 620-0876
Houston
713 528-2005

TEXAS TECHNICAL PRODUCTS CO.
Houston
713 526-0656

TEX-MEX INDUSTRIES INC.
Midland
915 684-5841

UTAH

DAVIS ASSOC.
Littleton, CO
303 795-1400

DIDIER/DENVER
Evergreen, CO
303 674-6000

HALL ELECTRONICS
Boise, ID
208 336-5894

TEXAS

**GIESLER
BROADCASTING
SUPPLY, INC.**

5914 Maple, Houston, TX 77074
(713) 774-3314

Professional advice, service, experience. Full line of RF & audio equipment. Offering transmitters through stylis. Call Bernie at (713) 774-3314.

TEXAS

MAGNETIC MEDIA
DALLAS, TEXAS
(214) 931-0404

Broadcast Video Systems for Professional users.

Hitachi broadcast VTR and camera equipment, Harris, Lenco, Tektronix, Grass Valley, C.E.I. Cameras, Datatron Editing Systems, Remote vans, Sony, JVC and Panasonic.

Complete design, installation, service and training.

Additional offices:
Austin, Amarillo, Denver, Odessa, Houston



3M
IS HELPING
A LOT OF
COMPANIES
FILL A
ONE-INCH
GAP.



For many broadcasters and production companies, wanting a one-inch VTR system is one thing. But finding the money to buy one is quite another. That's where 3M can help. We've put together a financing package that makes our TT-8000 VTR very affordable. And the special combination of enhanced editing features, automatic track following and controlled tape interchange program make the TT-8000 an even more attractive package. For a free brochure, call us toll-free at 1-800-328-1684 (1-800-792-1072 in Minnesota), and find out how we've brought professional quality one-inch VTR within reach.

Professional Audio/Video Equipment/3M.

3M hears you . . .

3M

Circle 235 on Reader Service Card

www.americanradiohistory.com



Telemet
A Geotel Company
185 Dixon Avenue, Amityville, L.I., New York 11701
(516) 842-2300 TWX 510-227-9850
Eastern Area Office—(914) 279-3231

Circle 237 on Reader Service Card

STANTRON
VIDEO CENTER
MODULAR DESK CONSOLES • VTR/VCR RACKS
CABINET CONSOLES • DUBBING RACKS • **ALL NEW**
for VIDEO PRODUCTION • POST-PRODUCTION
EDITING • ENG • EFP •

The STANTRON VIDEO CENTER series modular "add-on" features allow for maximum flexibility in designing console arrangements for professional, educational, industrial and communication VIDEO CENTERS. For a FREE copy of the "ALL-NEW" STANTRON VIDEO CENTER CATALOG #200, please write or call **STANTRON** mailing address:
P.O. Box 9158VC
No. Hollywood, CA 91609 U.S.A.

Toll Free: 1-800-821-0019
No. Calif. Toll Free: 1-800-821-0020
So. Calif. please call: 1-213-875-0800
TWX: 910-499-2177

factory:
6900-6918 Beck Ave., No. Hollywood, CA 91605



Circle 238 on Reader Service Card

Reps/Distributors

PERFORMANCE AUDIO
Salt Lake City
801 355-8890

RIA CORP.
Salt Lake City
801 486-8822

SKAGGS VIDEO SALES
Salt Lake City
801 539-1420

WESCOM MARKETING, INC.
Arvada, CO
303 422-7619

VERMONT

ABBOTT ALLISON CO., INC.
Meriden, CT
203 237-9232

BARTLETT ASSOC.
White Plains, NY
914 949-6476

HOLZBERG ASSOC.
Totowa, NJ
201 256-0455

KENTROL
Bennington
802 422-2222

VIRGINIA

BARTLETT ASSOC.
White Plains, NY
914 949-6476

EME I, INC.
High Point, NC
919 869-3335

EME IV, INC.
Williamsburg
804 253-0171

DAVID GREEN BROADCAST CONSULTANTS
Leesburg
703 777-6500

JULLIEN ENTERPRISES
Fairfax
703 573-5870

MIDWEST CORP.
Virginia Beach
804 464-6256

ROBERT SLYSE ELECTRONICS
Arlington
703 525-7272

WILTRONIX, INC.
Washington Grove, MD
301 258-7676

WASHINGTON

ALLIED BROADCAST EQUIPMENT
Federal Way
206 927-4337

BENNETT ENGINEERING ASSOC., INC.
Mercer Island
206 232-3550

BROADCAST SUPPLY WEST
Tacoma
206 565-2301

B.S.W.
Tacoma
206 565-2301

R.W. CAMPBELL, INC.
Seattle
206 622-3403

D.P.M., INC.
Bellevue
206 747-3309

GEMINI ELECTRONICS MARKETING, INC.
Edmonds
206 776-3121

MARCOM
Seattle
206 722-2636

NORTHSHORE MARKETING, INC.
Seattle
206 524-8672

NU-COM ASSOC., INC.
Seattle
206 364-9911

TOPP ENGINEERING SALES CORP.
Bellevue
206 747-5400

RMS SOUND
Seattle
206 362-0491

WEST VIRGINIA

EME I, INC.
High Point, NC
919 869-3335

EME IV, INC.
Williamsburg, VA
804 253-0171

SAVE A BUCK!

ECONOMY MEANS THOMSON-CSF
UHF-TV TETRODES AND CIRCUIT ASSEMBLIES

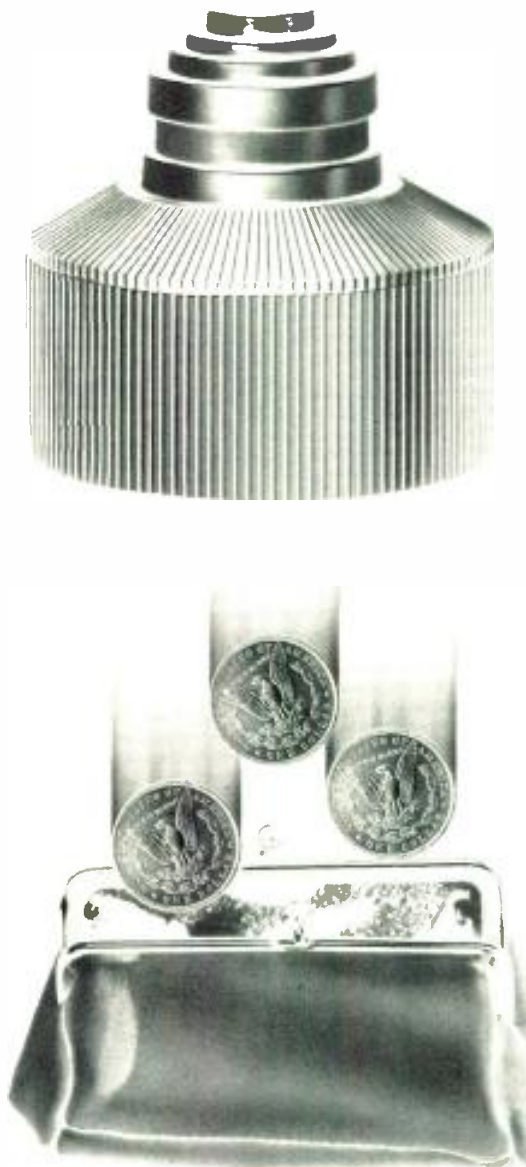

To save a buck, and even a bundle, check out THOMSON-CSF advanced-design Pyrobloc[®]-grid tetrodes. Featuring the highest electrical efficiency, extra-high gain and superior linearity, they're a sure way to beat soaring energy costs.

Some of the most in-demand models are the 5-kW* TH 393, the 10-kW* TH 382, and the TH 582, which delivers up to 20 kW*. And all of them are available with matched THOMSON-CSF coaxial-cavity circuit assemblies, for an added assurance of top-quality performance. Don't wait! The sooner you install THOMSON-CSF tetrodes, the sooner your savings will start.

* In video-carrier amplification alone.



THOMSON-CSF COMPONENTS CORPORATION ELECTRON TUBE DIVISION
301 ROUTE SEVENTEEN NORTH / RUTHERFORD, NEW JERSEY 07070 / TEL.: (1.201) 438 23-00 / TWX: 710 989.7286

BRAZIL
THOMSON CSF
COMPONENTES DO BRASIL Ltda
SAO PAULO (11) 542 47 22

CANADA
THOMSON CSF CANADA Ltd./Ltée.
OTTAWA (613) 236.36.28

FRANCE
THOMSON CSF
DIVISION TUBES ÉLECTRONIQUES
BOULOGNE BILLANCOURT
TEL.: (1) 604 81.75

GERMANY
THOMSON CSF
BAUELEMENTE GmbH
MÜNCHEN (089) 78 79-0

UNITED KINGDOM
THOMSON CSF
COMPONENTS AND MATERIALS Ltd.
BASINGSTOKE (256) 29.155

ITALY
THOMSON CSF COMPONENTI
ROMA (6) 638 14.58

SPAIN
THOMSON-CSF
COMPONENTES Y TUBOS S.A.
MADRID (1) 419.88.42

SWEDEN
THOMSON CSF
KOMPONENTER & ELEKTRONRÖR AB
STOCKHOLM (8) 225 815

JAPAN
THOMSON JAPAN K.K.
TOKYO (3) 264.63.46

Circle 236 on Reader Service Card

MEET YOUR DEADLINES WITH LEASAMETRIC

Do you have a special event coming up? Is your test equipment out for repair or annual calibration? Do you need additional test equipment for proof of performance testing? Call Leasametric now and rent the equipment you need to meet all your deadlines.

We'll get you on-line, on time with spectrum analyzers, NTSC signal generators, Vectorscopes, waveform monitors, color monitors, portable microwave radios and more.

From the best names in the business: Tektronix, Ikegami, Microwave Associates, Hewlett-Packard and others.

When time is critical, turn to the rental leader of electronic broadcast test equipment. For more information and the name of your nearest Leasametric office call 800-227-1817 today.

Rent the best names in the business from the best name in the business.

Leasametric

1164 Triton Drive, Foster City, CA 94404

Circle 239 on Reader Service Card



SONY FORMALLY INTRODUCES THE ECM 50-PBW.

Covering the Emmys? The Grammys? The Oscars? Or merely having a little tête-à-tête with the President of the United States in front of 40 million people? You'll find the world's most preferred broadcast mic is now even more suited for the occasion. Because the legendary Sony ECM 50 lavalier mic now comes in an elegant, black satin finish.

Ask your Sony dealer about the ECM 50. It's what all the best-dressed newscasters will be wearing this year.

SONY
Professional Audio

Sony Communications Products Company, Sony Drive, Park Ridge, New Jersey 07656. © 1983 Sony Corp. of America. Sony is a registered trademark of the Sony Corp.

Circle 240 on Reader Service Card

WILTRONIX, INC.
Washington Grove, MD
301 258-7676

WISCONSIN

AINSLIE CO.
Edina, MN
612 920-2996

BROADCAST ELECTRONICS SERVICE
Fort Atkinson
414 563-7236

CALUMET COMMUNICATIONS
Arlington Heights, IL
312 228-1855

EMMONS ASSOC.
Burnsville, MN
612 890-8920

ENTERPRISES, INC.
Hartford
414 966-3303

FULL COMPASS SYSTEMS
Madison
608 271-1100

RYAN & ASSOC.
Hawthorne Woods, IL
312 438-2905

WYOMING

ABCO INC.
Casper
307 577-1851

DAVIS ASSOC.
Littleton, CO
303 795-1400

DIDIER/DENVER
Evergreen, CO
303 674-6000

HALL ELECTRONICS
Boise, ID
208 336-5894

WESCOM MARKETING, INC.
Arvada, CO
303 422-7619

CANADA

BCB ELECTRONIC SALES LTD.
Bolton, ONT
416 857-0790

CAMARTRON COMMUNICATIONS, INC.
Willowdale, Toronto, ONT
416 494-6978

A.B. CHANCE OF CANADA LTD.
Scarborough, ONT
416 759-1144

COMAD COMMUNICATIONS LTD.
Rexdale, ONT
416 245-1734

COMMERCIAL ELECTRONICS
Vancouver, BC
604 669-5525

ELECTRO & OPTICAL SYSTEMS
Scarborough, ONT
416 439-9333

FRESCO
Montreal
514 332-3430

J-MAR ELECTRONICS LTD.
Toronto, ONT
416 421-9080

MANTA ELECTRONICS GROUP
Toronto, ONT
416 868-0513

MARUNO ELECTRONICS LTD.
Toronto, ONT
416 255-8231

MSC ELECTRONICS LTD.
Downsview, ONT
416 661-4180

NORTEC CALGARY BRANCH
Calgary, ALB
403 252-8141

NORTEC WEST LTD.
Vancouver, BC
604 872-8525

NORTEC WEST LTD.
Calgary, ALB
403 252-8141

OAKWOOD AUDIO LABS LTD.
Winnipeg, MAN
204 786-6715

SONOTECHNIQUE
Quebec
514 739-3368

PUERTO RICO

MARIO FRANCESCHINI INC.
Santurce
809 723-4511



New Harris Wavestar™...

The most reliable UHF slot antenna ever designed... because it's waveguide!

The new Harris Wavestar is the only slotted waveguide UHF antenna now available...the ultimate in design simplicity. No center conductor. No couplers. No insulators. Fewer parts mean fewer problems. And that means less off-air time and lower maintenance costs.

Additional advantages of waveguide over coax antennas include higher power handling capabilities and greatly increased safety margins to prevent arcing.

The Wavestar pattern performance is excellent by any standard. Cardioid and peanut directional patterns are currently available, and a highly circular omnidirectional pattern will follow soon. All of these Wavestar configurations provide the smooth elevation patterns necessary for high signal strength and minimum ghosting over the entire coverage area.

The Wavestar is a low windload design for tower top or side mounting. High mechanical strength and rigidity minimize picture variations caused by wind sway.

Every Harris antenna is completely assembled and tested at the Harris antenna test range...the largest, most comprehensive facility of its kind.

The range is located in an area far from the pattern-distorting clutter of urban development. Situated atop a 230-foot bluff, with test transmitters located up to 3 miles away on flat, unobstructed bottom lands, the range offers ideal conditions for testing, approaching the "free space" situation of an installed antenna.

Here, theoretical azimuth and elevation patterns are verified with the most accurate and sophisticated test instruments available—translating the theory of a calculated pattern into the reality of actual antenna performance.

You can depend on Wavestar for top reliability. And you can be confident that your Wavestar antenna will be thoroughly tested by Harris to meet your exact pattern requirements.

Contact Harris Corporation, Broadcast Division, P.O. Box 4290, Quincy, Illinois 62305-4290. 217/222-8200.



HARRIS

ADVERTISER'S INDEX

Use Reader Service Card on Facing Page ►

Manufacturer	Page No.	Circle No.	Manufacturer	Page No.	Circle No.	Manufacturer	Page No.	Circle No.
Abekas Video Systems	127	190	Landy Assoc., Inc.	152	214	Townsend Assoc., Inc.	119	183
Adams Smith	120	184	Lake Systems Corp.	131	194	UMC Electronics Co.	182	244
ADM Technology, Inc.	120	185	Laumic Co., Inc.	152	215	UREI	145	206
AFA Products	C-2	—	LEA Inc.	94	164			
AFA Systems	150	212	Leader Instruments	149	211	Valley People, Inc.	40	128
Allen Avionics, Inc.	32	122	Leasametric	174	239	Varian, Eimac Div.	65	144
Allen Osborne Assoc.	156	220	Listec Television Equip. Corp.	184	248		169	232
Alpha Audio	142	202	Lowet-Light, Inc.	148	209	Videotek, Inc.	37	126
Amber Electro Design Ltd.	66	145	LPB, Inc.	84	157			
Ampex AVSD	78	153				Ward-Beck Systems Ltd.	C-4	—
Ampex MTD	121	186	3M/Magnetic Tape Div.	56-57	—	Yamaha Combo	43	130
Anton/Bauer, Inc.	79	154	3M/Pro-Av	9	104		44	131
Aristocart	135	196		171	235			
Audio Technologies, Inc.	17	110	Marti Electronics	52	138			
Audiotronics, Inc.	92	162	MCI/Quantel	24	118			
	176	241	MCI (Div. of Sony America)	22-23	117			
	48	134	Merlin Engineering	14	107			
	125	189		106	173			
			Microtime, Inc.	29	120			
				31	121			
			Midwest Corp.	15	108			
			Minoita Corp.	20	115			
			Moseley Assoc., Inc.	102	170			
				103	171			
			Motorola, Inc.	97	167			
			Nautical Electronic Labs, Ltd.	130	193			
			NEC America, Inc.	75	150			
				183	245			
			Rupert Neve, Inc.	133	195			
			Northeast Productions	164	228			
			Oki Electronic Industry Ltd.	123	187			
			Orban Associates, Inc.	19	112,113,114			
				180	242			
			Otarl Corp.	58	141			
			Pacific Recorders & Engineering Corp.	55	140			
				52	137			
			Perrott Engineering	159	221			
			Pheips Dodge Communications Co.	26	119			
			Phillips Television Systems, Inc.	95	166			
			Potomac Instruments					
			QSI Systems, Inc.	128	191			
			Quanta Corp.	105	172			
			Ramko Research	7	103			
			RCA Broadcast Systems	38-39	127			
			RCA E/O	165	226			
			Rohde & Schwarz	67	146			
			RTS Systems	83	156			
			Sachtler GmbH	101	169			
			Schneider TV Lenses	116	181			
			Sharp Electronics Corp.	10-11	105			
				13	106			
			Shintron	153	213			
			Shook Electronics	184	247			
			Shure Bros., Inc.	99	168			
			Sony Broadcast	2-3	—			
			Sony Pro Audio	174	240			
			Sound Technology	161	224			
			Stainless, Inc.	77	152			
			Stantron	172	238			
			Storel Corp.	112	178			
			Studer Revox America, Inc.	117	182			
			Surcom Assoc.	166	231			
			Swiderski Electronics, Inc.	148	210			
			Tandberg	144	204			
			Telemet	172	237			
			Telex Communications, Inc.	41	129			
				85	158			
			Thomson-CSF Broadcast	C-3	251			
			Thomson-CSF/DRE-DRE	91	161			
			Thomson-CSF/DTE	173	236			
			Time & Frequency Technology	16	109			
				140	200			
				141	201			

SALES OFFICES



Broadcast Management/Engineering

295 Madison Ave.
New York, New York 10017
Telex: 64-4001

Eastern & Central States
James C. Maywait,
Vice President, Sales

295 Madison Avenue
New York, New York 10017
212-685-5320
James C. Maywait
Gene Kinsella

Western States
Neal Wilder, Associate Publisher

1021 South Wolfe Road, Suite 290
Sunnyvale, CA 94086
408-720-0222
Neal Wilder
Charleen Kennedy

5015 Birch Street, Office One
Newport Beach, CA 92660
714-851-1461
Neal Wilder

United Kingdom/Europe

28 Eaton Row
London SW1 OJA, England
Telephone: 01 235 8431
Bronwyn Holmes
Derek Hopkins
Ruben Veksner

Japan/Far East

Eiraku Building
1-13-9, Ginza,
Chuo-Ku, Tokyo 104 Japan
03 (562) 4781
S. Yasui
K. Yamamoto
Y. Yozaki



AUDIO PROCESSORS
MODULAR COMPRESSOR - DA

FREE DETAILED BROCHURES



DISTRIBUTION AMPLIFIERS



PHONO
PREAMPLIFIERS



DUAL MIKE,
LINE, & POWER AMPLIFIERS
RACK MOUNTING

Micro Amp Series by



AUDIO
TECHNOLOGIES
INCORPORATED

328 MAPLE AVENUE
HORSHAM, PA. 19044
(215) 443-0330

Circle 241 on Reader Service Card

GREAT IDEA CONTEST

Here's a chance to share your own personal solutions to some of broadcasting's most vexing engineering needs

Each month, *BM/E* presents two engineering problems and invites you to submit solutions complete with diagrams. *BM/E*'s editors will read the entries and select the best for publication—giving readers an opportunity to vote for the idea they consider best by using the ballot area on the Reader Service Card.

We will pay \$10 for each entry printed. In addition, the solution in each month's competition receiving the most votes on our Reader Service Card will win \$50.00. So put on your thinking cap and submit an answer to either of the problems outlined below . . . and be sure to watch this section for the solutions.

NEW, BIGGER PRIZE: \$50.00 FOR EACH CONTEST WINNER!

Problem 21: Impedance Matcher

When recording audio in the field, the engineer is often confronted with a problem of matching various mic and line impedances with the audio recorder. What is your design for a low-cost, lightweight system to allow the matching of recorder and input impedances?

**Solutions to Problem 21
must be received by
August 22, 1983 and will be
printed in the October, 1983 issue**

Problem 22: Commercial Production Automation

When producing a tape for a commercial spot, it is often necessary to coordinate the different audio elements located on different tape decks. Design a system that will allow the insertion of audio sources from several different cart machines, in the proper order, onto an audio or video master tape.

**Solutions to Problem 22
must be received by
September 21, 1983 and will be
printed in the November, 1983 issue**

CONTEST RULES

- 1. How to Enter:** Submit your ideas on how to solve the problems, together with any schematic diagrams, photographs, or other supporting material. Entries should be roughly 500 words long. Mail the entries to *BM/E*'s Great Ideas Contest, 295 Madison Avenue, New York, NY 10017. Use the official entry form or a separate piece of paper with your name, station or facility, address, and telephone number.
- 2. Voting and Prizes:** *BM/E*'s editors will read all entries and select some for publication; the decision of the editors is final. Those selected for publication will receive a \$10 honorarium. Each month, readers will have an opportunity to vote for the solution they consider the best by using the Reader Service Card. *BM/E* will announce the solution receiving the most votes and will award the winner of each month's competition a \$50.00 check.
- 3. Eligibility:** All station and production facility personnel are eligible to enter solutions based on equipment already built or on ideas of how the problem should be solved. Consultants are welcome to submit ideas if they indicate at which facility the idea is in use. Manufacturers of equipment are not eligible to enter. Those submitting solutions are urged to think through their ideas carefully to be certain ideas conform to FCC specs and are in line with manufacturers' warranty guidelines.

Mail Official Entry Form to:

BM/E's Great Ideas Contest
295 Madison Avenue, New York, NY 10017

Solution to Problem # _____

Your Name: _____

Title: _____

Station or Facility: _____

Address: _____

Telephone: (_____) _____

I assert that, to the best of my knowledge, the idea submitted is original with this station or facility, and I hereby give *BM/E* permission to publish the material.

Signed _____

Date _____

SOLUTIONS to problem 18: Using Home Computers for Station Automation

Allen W. Marshall III, president and GM of WKEU AM and FM, wrote: "Has anyone been able to design a home-built automation system using a small, relatively inexpensive computer such as the Apple or TRS-80? Everything that the salesmen pitch me is in the \$25,000 range and up. Surely with the price of home computers they can be put to good use at the broadcast station." Here are the finalists, as selected by *BM/E's* editors.*

SOLUTION A

Kim Parham
Design Engineer
WTVS, Detroit, MI

Using a TRS-80III, we controlled six VTRs and two switching devices. The interface consists of three TTL chips and a power supply. The software was Basic and made use of the TRS-80's commands.

The software was designed to start the VTRs and enable the switcher at specified times during the day. For example, at 06:00:00 the videotaped program is to be aired. The software compares the time (which has been entered by an operator the day before) to the TRS-80's real-time clock. Once the two times compare, a pulse (logic level 5 V) is sent to the output ports of the TRS-80 and starts the VTR. Five sec-

onds later, after the machine starts, the switcher is enabled. All the commands are initiated by the software.

The specified time at which the videotape machine and the switcher are enabled are stored as data in a matrix form. In the matrix, along with the data, is the order in which the machines will start and which switcher will be enabled. We used two channels, each with three machines, and one switcher.

The data is set in the matrix in the order it is to be used. For example, column 1, row 1 of the matrix has the time 06:00:00 in column 1, row 2, and so on through the other slots in the matrix.

This matrix setup is true for the machine order also. Using the matrix, it is possible to store large amounts of data (a week of video programming).

The interface consists of three TTL devices (7404, 7400, and 7442), a power supply, and an assortment of connectors and wires. The data is bused from the printer ports to the 7404 and the 7400. The 7404 is a hex inverter positive logic.

The first six data ports are used to control the switching devices. The first four data ports and data port 7 are also used to control the videotape machines.

**Readers are invited to send a stamped, self-addressed envelope to receive complete program details of Solutions A and B proposed herein. (Solution C appears in full.) Programs should not be a factor, however, in voting for the best solution.—Ed.*

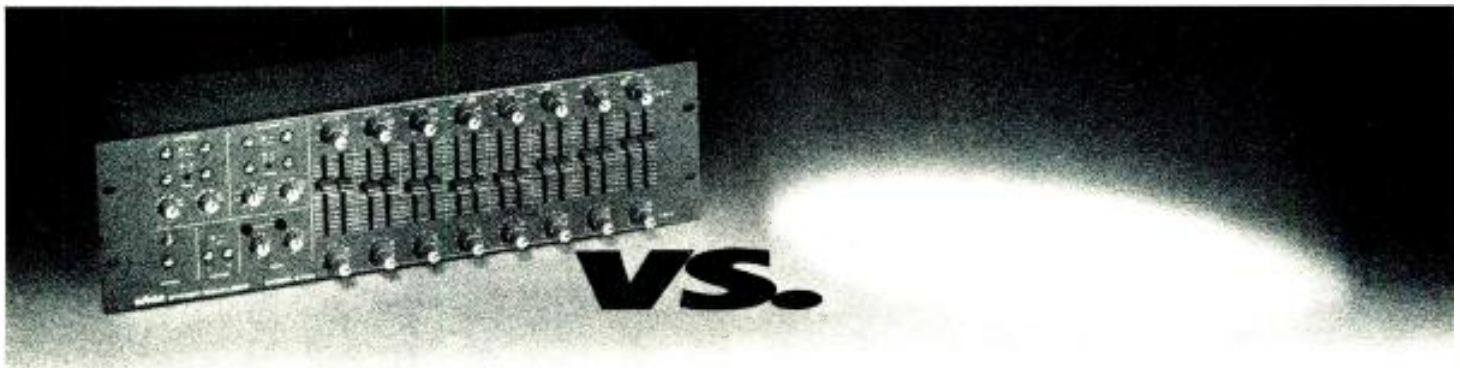

The unequalled equalizer.

Not all equalizers are created equal. You know that from experience. So do we. Our years of parametric design experience let us build so much performance and versatility into our 672A (mono) and 674A (stereo) graphic/parametric equalizers that *Modern Recording & Music* (October, 1981) described the 674A as "... the most powerful equalizing tool for pro audio work that I have yet to come across".

They clearly appreciated the versatility and functionality of eight bands of EQ with fully adjustable center frequency and bandwidth, plus the availability of 12dB/octave highpass and lowpass filters to limit signal bandwidth or to serve as a full electronic crossover.

No matter what your application—production, program shaping, room tuning, reinforcement work, or clean-up chores—you can count on Orban's heavy-duty professional construction and equally professional documentation and service. Find out why the Orban 672A/674A's are truly the "un-equalled equalizers!"

orban

Orban Associates Inc. 645 Bryant Street
San Francisco, CA 94107 (415) 957-1067
TLX: 17-1480

Circle 242 on Reader Service Card

BM/E's ENG/EFP/EPP HANDBOOK

THE MOST AUTHORITATIVE, COMPREHENSIVE GUIDE TO THE TECHNOLOGY AND TECHNIQUES OF THE 80'S.

THE DEFINITIVE SOURCE for video equipment evaluation selection and acquisition. Published by BM/E — Broadcast Management/Engineering, this guidebook is designed to be the authoritative text on the entire subject of electronic journalism, field production and post-production in the 80's. A primer for newcomers, and advanced report for professionals, the Handbook is organized to allow you to select the proper equipment for any operation — from the simplest to the most complex — and plan for expansion as your production requirements grow.

FACTUAL. In 570 fact-filled pages, liberally illustrated with photos, diagrams and charts, the Handbook offers detailed analysis of existing equipment and systems, probing strengths and shortcomings of current product design and covering key parameters for product comparison. It offers guidance in long range organization and systems planning, as well as predictions about emerging technology and trends. Authored by C. Robert Paulson, this video production handbook is written in an informal style that satisfies the needs of both the technical and non-technical reader.

ESSENTIAL. With constant changes in technology and the proliferation of products, there are no "simple" purchasing decisions in the ENG/EFP/EPP market. With each buying decision impacting on plans for the future, you need all the help and advice you can get. Now. Whether you're technical or non-technical, operations or management, this book is your required reference for coping with the "digital decade," for assuring productivity and profitability in your operations, now and in the future.

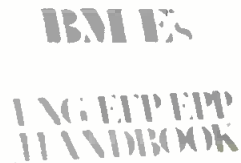

EFP/EPP market. With each buying decision impacting on plans for the future, you need all the help and advice you can get. Now. Whether you're technical or non-technical, operations or management, this book is your required reference for coping with the "digital decade," for assuring productivity and profitability in your operations, now and in the future.

CONTENTS

Part I — Overview

- Chapter 1. What's Happening in TV Communication
- Chapter 2. Communication System Organization
- Chapter 3. Trends in Communication Systems

Part II — Electronic Field Production

- Chapter 4. Cameras, Lenses and Lighting
- Chapter 5. Video and Audio Recorders
- Chapter 6. Field System Accessories
- Chapter 7. Planning & Acquiring ENG/EFP Systems

Part III — Electronic Post-Production

- Chapter 8. Editing Systems and Controllers
- Chapter 9. Video Signal Processing — Switchers
- Chapter 10. Video Signal Processing — TBC's/Quantels
- Chapter 11. Audio Signal Processing — Studio Audio/PCM/etc.
- Chapter 12. EPP System Accessories
- Chapter 13. Planning & Acquiring EPP Products

Appendices

- A. Public Policy & Technological Developments
- B. TV Standards
- C. Bibliography & Reference Section

ORDER NOW. LIMITED EDITION.

PLEASE SEND _____ COPIES OF BM/E's ENG/EFP/EPP HANDBOOK @ 39.95 EACH.
IF CHECK ACCOMPANIES ORDER, PUBLISHER PAYS POSTAGE AND HANDLING.

CHECK ENCLOSED \$ _____ NAME _____
 CHARGE TO MY — BANKAMERICARD _____
VISA — MASTERCARD _____
_____ COMPANY _____
EXP. DATE _____ CITY _____ STATE _____ ZIP _____

Make check payable to Broadcast Management/Engineering

NY State Residents add applicable sales tax

BM/E — 295 Madison Avenue, New York, N.Y. 10017

GREAT IDEAS

Using the TRS-80's software out-command and a decimal number from 1 to 255 (code), control is possible for the switchers and the machines. When the data matches the real-time clock, the data is bused by use of the outcommand and a decimal code. In our example we will use code 65 (binary 10000010) to start machine 1 and enable the switcher. The first four (most significant bite) data ports (1000) are bused to the 7400 and combined with the data from port 7. The switcher is enabled with the same four data ports and data port 5 using decimal 136 (binary 1000100).

Including the cost of the wires, connector, and containment box, the approximate cost of the interface totaled less than \$100.00.

SOLUTION B

Walt Nyren
Chief Engineer

National Christian Network, Inc.
Cocoa, FL

I had been aware for some time of many of the tape automation problems that Randy Henry, owner and GM of WPIO, Titusville, FL, was having at his station. At the same time, I was teaching

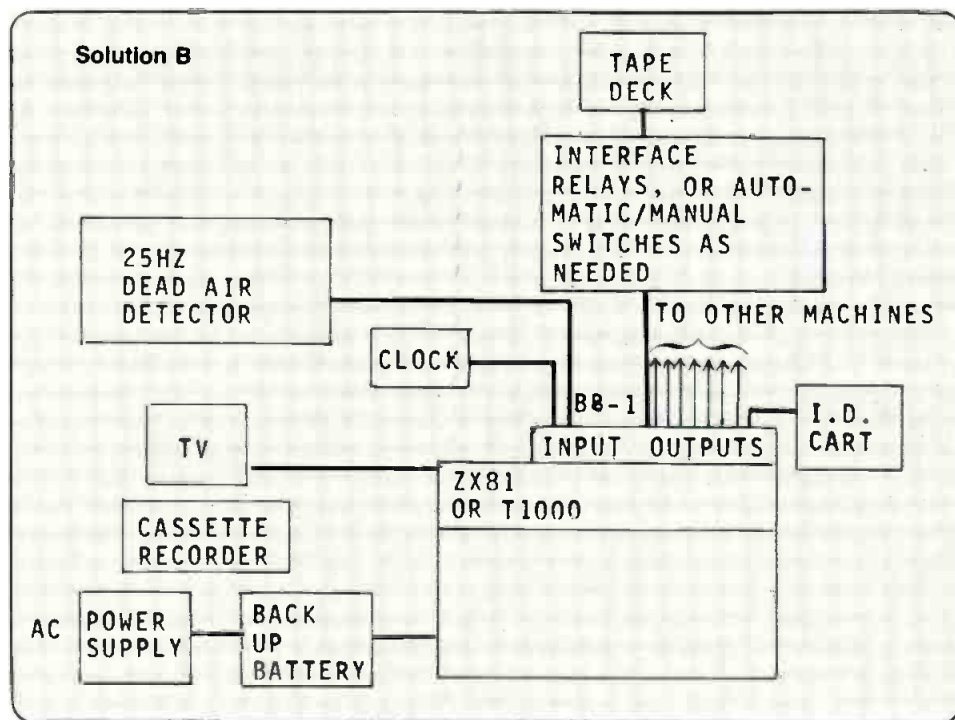

myself, mostly out of curiosity, Basic programming on a Sinclair ZX81. I purchased a BB-1 control module from Byte-Back Company (Leesville, SC) with eight independent S.P.S.T. relays and eight independent TTL inputs.

About two days later I had a program running, using the LEDs on the BB-1 as "tape decks" and "cart machines" and clip leads for a 25 Hz cue tone detector. It took about a month for the station to give the system a try. Just to be on the safe side, they wired the tape deck controls through a connector that would work with the BB-1 or could be plugged back into the old system in case a problem came up. The system worked fine!

In the very general wiring diagram, modifications will have to be made to interface with different tape machines. WPIO is using five Pioneer 707 auto reversing tape decks, which allow complete unattended operation. Three cart machines are also in the system. The ID machine is on the eighth relay.

The inputs consist of a 25 Hz cue tone detector along with a dead air detector on input 1 and a clock switch that closes on the top of the hour on input 2.

An 8- or 9-volt backup battery should be used to prevent loss of computer program in the event of a power failure.

The program is a "getcha started" approach that can be used with the Pioneer 707 tape decks. Lines 2-6 set system variables. The program then goes to line 600, where the machine sequence is entered one number at a time with an ENTER command. Sixteen entries can be made, but the last entry must be a zero to indicate the end of the string.

It's AUTOMATIC

The Splice Finder That Works Every Time.

(automatically — with no adjustments)

UMC Beucart
SFE-100 Splice Finder
(with Bulk Eraser)

It's the "built-in" features that make the Beucart Automatic Splice Finder a trouble-free tool for the broadcast industry.

The all new opto-mechanical sensing system alleviates many problems usually encountered by users of endless loop cartridge tapes.

- ▶ No adjustments to make
- ▶ Locate splice automatically
- ▶ Controlled stop
- ▶ Automatic Cartridge ejector
- ▶ Bulk eraser/Built-in
- ▶ Separate splice finding and eraser functions
- ▶ Opto-Mechanical Sensor

UMC

UMC Electronics Company
460 Sackett Point Road
North Haven, Connecticut 06473
Phone (203) 288-7731

Outside Connecticut, toll free, (800) 243-6178

Circle 244 on Reader Service Card

VOTE NOW!
BALLOT ON READER SERVICE CARD

Solution C, Figure 1: Hardwired automation

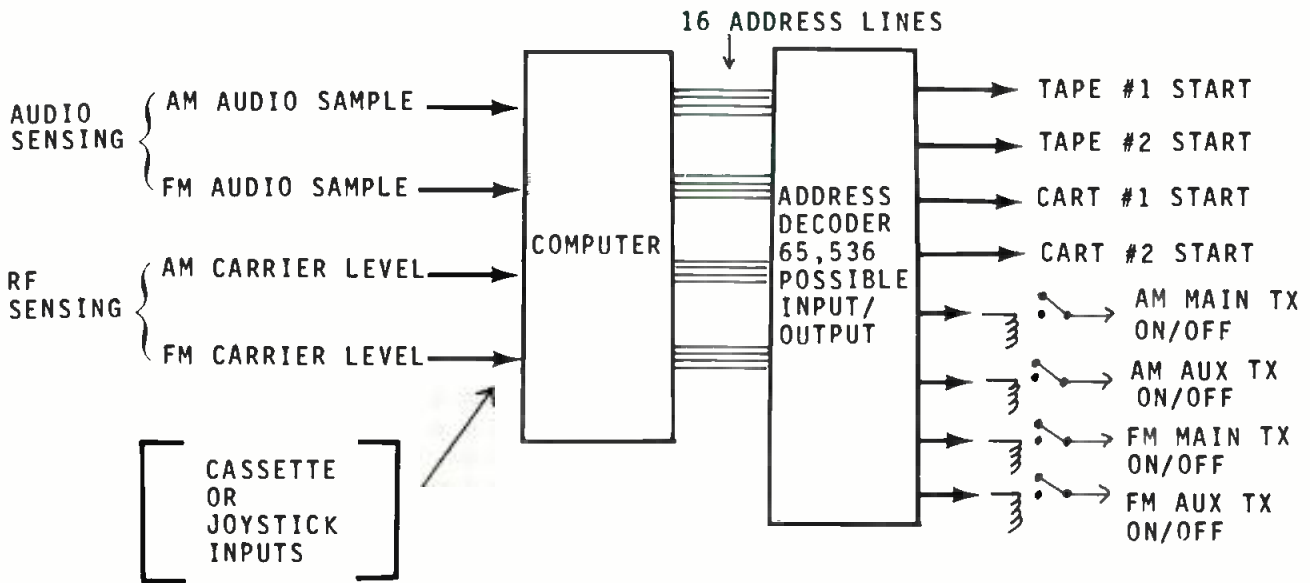

The first machine in the sequence is then started. The program then goes to lines 10-70 to await a cue tone or ID switch closure.

Currently three automation systems are being designed and constructed for the National Christian Network in Cocoa, FL. These are using the Timex/Sinclair 1000 & BB-1 operating four Otari ARS-1000s.

VOTE NOW!
BALLOT ON READER SERVICE CARD

SOLUTION C

John J. Yurek
 Consulting Engineer
 Irwin, PA

I have been using small home computers for automated broadcast systems and cable TV nondupe switchers for the past couple of years. I personally prefer

Independent Dallas Production Company has immediate, full-time openings for the following positions:

ENGINEERING SUPERVISOR
 Duties include the supervision of operational Engineers and maintenance of remote trucks.

MAINTENANCE ENGINEER
 Duties include technical maintenance for all studio equipment.

COMPUTER EDITOR
 Experienced. Must be able to work comfortably in state of the art editing suite.

Rush resume and salary expected to:

Continental Productions
 3900 Harry Hines Blvd.
 Dallas, Texas 75219
 or contact
 Harold Nash at (214) 521-3900

An Equal Opportunity Employer

**The first
 3-chip
 100%
 solid-
 state color camera.**



Another everyday breakthrough from NEC.

NEC quietly outdistances the competition again. With the first broadcast-quality, 100% solid-state ENG color camera—the SP-3.

Because the SP-3 uses 3 NEC CCD chips instead of pickup tubes, it never needs registering. Delivers over 500 lines of resolution without geometric distortion or video burn. Weighs only 7.3 lbs. Better still, you can use it with any format, "built-in" 1/2" VTR or by cable to any VTR for even more versatility.

Amazing? Of course. But, it's all in a day's work. For more information on the SP-3, call NEC at 1-800-323-6656.

NEC

IMAGINE WHAT WE'LL DO NEXT.

NEC America, Inc.
 Broadcast Equipment Division
 130 Martin Lane
 Elk Grove Village, Illinois 60007
 In Illinois: (312) 640-3792

Circle 245 on Reader Service Card

INTRODUCING SYSTEM R

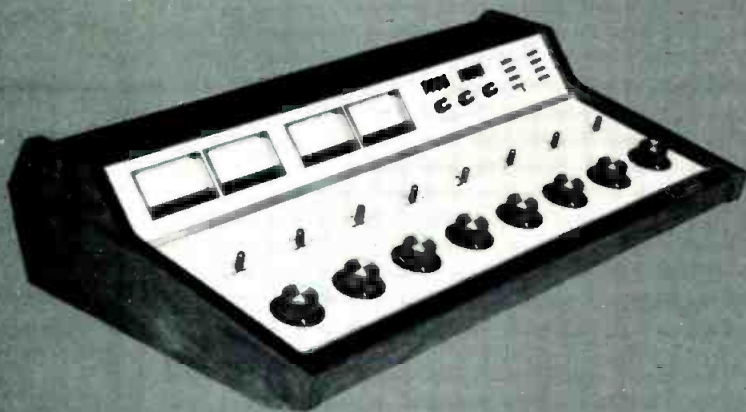

Our newest stereo audio console features Penny & Giles® newest fader, a remarkable rotary which you'll have to feel to believe. Measuring a compact 32 inches wide, SYSTEM R combines conventional controls with the advanced audio technology and superb styling you'd expect from Broadcast Audio Corporation. If you need rotary faders, compact size, superb audio quality, and a modest price - we've just designed your audio console - SYSTEM R!

**BROADCAST
AUDIO CORPORATION**

11306 SUNCO DRIVE
RANCHO CORDOVA, CA 95670
(916) 635-1048

Circle 246 on Reader Service Card

TELEVISION PRODUCTION VEHICLES



SHOOK ELECTRONIC ENTERPRISES, INC.
6640 Topper Parkway, San Antonio, Texas 78233
(512) 653-6761

Circle 247 on Reader Service Card

Affordable Prompting!

- DIRECT EYE CONTACT PROMPTING
- 12VDC SILENT OPERATION
- LIGHTWEIGHT
- FAST HANDWRITTEN SCRIPTS
- REUSABLE SCRIPT FILM
- FLUORESCENT LIGHTING
- HAND SPEED & DIRECTION CONTROL
- FOR ALL ENG AND FILM CAMERAS



\$2,100⁰⁰
COMPLETE
WITH CARRYING CASE

**Listec Television
Equipment
Corporation**

39 Cain Drive,
Plainview, New York 11803
(516) 694-8963

Listec (West) Corp.
1619 Cosmic Way,
Glendale, California 91201
(213) 247-9247

Circle 248 on Reader Service Card

GREAT IDEAS

the Radio Shack TRS-80 color computer because of its internal D/A converters, ease of programming, and, of course, its cost. I will briefly describe two methods of controlling external equipment from the computer. The first is "hard wired" and the second system is wireless.

Figure 1 shows a simple address decoder connected to the microcomputer bus. This can be wired on a "breadboard" and be hard-wired to the computer bus, or, in the case of the color computer, simply plugged into the ROM pack connector.

The address decoder decodes a small block of computer memory addresses and allows data to flow to/from the outside world. The various functions can be turned on/off with a simple POKE command from Basic. Various functions can be monitored via the PEEK command. If a software or hardware clock program is run as part of the Basic program, it is a simple matter to sequence selected functions at preprogrammed times.

One disadvantage of this method is that a lot of wiring must be installed between the computer and the system to be automated. This wiring can be time-consuming to install and opens the way for voltage transients to enter the computer via the added wiring. Also, the address decoder must be hand-wired.

The computer can be in the office, control room, or in the back closet, as there is no wiring with which to contend. Instead of using an address decoder and external wiring for communication, this system makes use of the wireless "BSR" type light/appliance modules available for the past several years, using 120 VAC wiring as the data bus. Radio Shack makes a "Plug & Power Controller" that simply plugs between the cassette port and the power line. This system even comes with prepackaged software that is useable as is for a simple automation system. It was designed to "automate" your house! I prefer this system, as it eliminates the custom-designed address decoder, and is available off the shelf at a reasonable price. It also eliminates any possibility of voltage spikes getting back into the computer.

With either of the above systems, don't overlook the possibility of connecting the cassette input to an off-air monitor or the automation system audio output.

VOTE NOW!
BALLOT ON READER SERVICE CARD

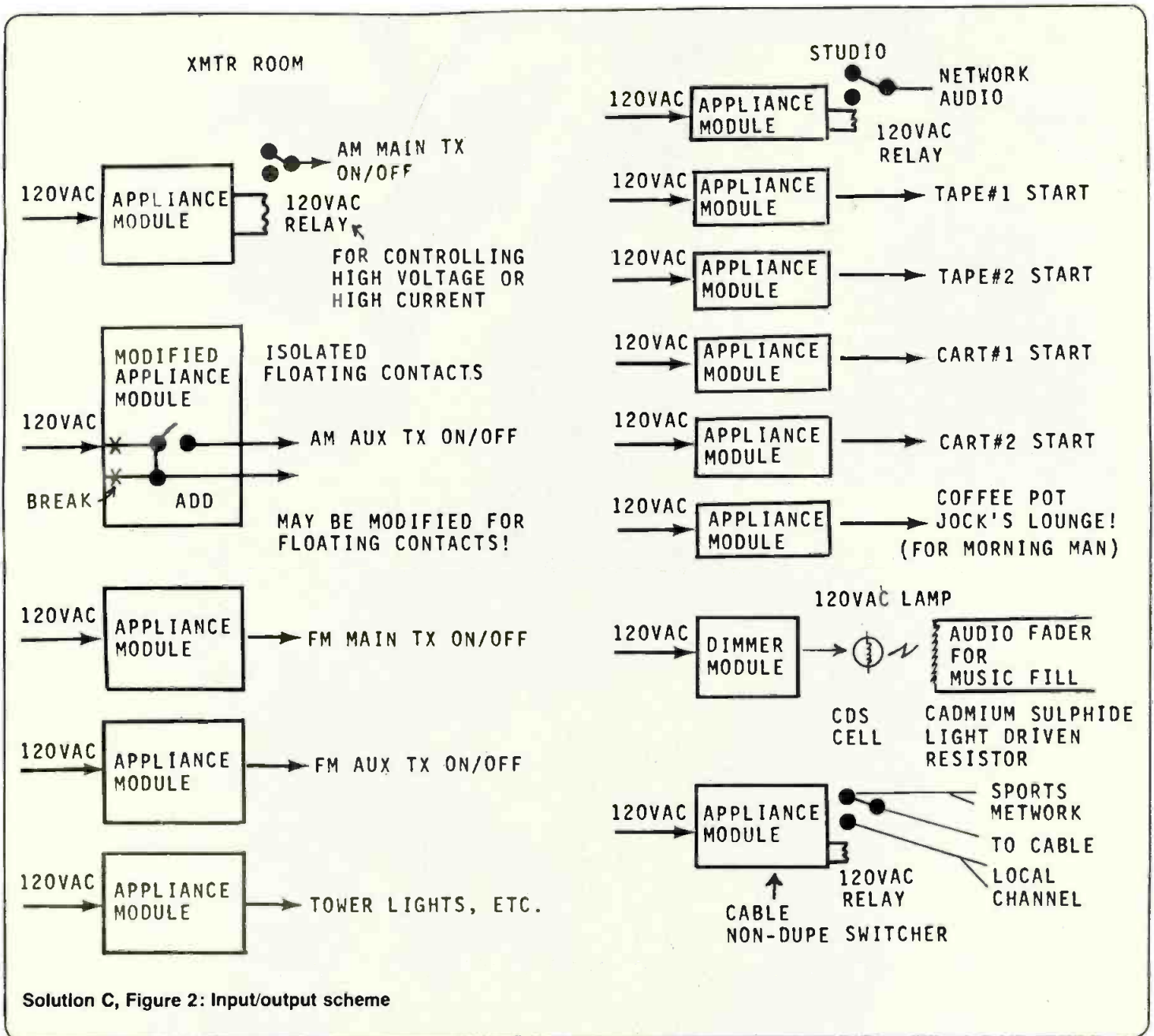

Solution C, Figure 2: Input/output scheme

The joystick inputs on the color computer (four are available as original equipment) can be used to sample any analog voltage such as for sampling the transmitter output. With both the audio

and RF carrier sensed by the "automation system," it can make intelligent decisions as to what to do next. It is even possible to use the cassette relay to dial the telephone and alert someone.

VOTE NOW!
BALLOT ON READER SERVICE CARD

VICTOR DUNCAN IS READY!

THE EDGE™
 Easy To Learn—Simple To Use
 Compact Design/Finger Tip Control
SMART KEYS™
 Internal Memory Re-Edit and List Ripping
 Auto Assembly—VTR Mix 1/2", 3/4", or 1"
 Time Code Pulse Count Editing
 Built In Dissolver
 Six Preview Functions
 340X Edit Decision List Input Output
 Get THE EDGE™ On Your Competition with CMX and Victor Duncan, Inc.

CMX ORROX
 The World Standard for Editing

VICTOR DUNCAN, INC.
 EXCLUSIVE REPRESENTATIVE FOR TEXAS, OKLAHOMA, ILLINOIS
 DALLAS—Four Dallas Communications Complex Irving, Tx 75039 • (214) 869-0200
 CHICAGO—661 N. La Salle Chicago, IL 60610 • (312) 943-7300

Circle 249 on Reader Service Card

BUSINESS BRIEFS



Design station of the first commercially installed MCI/Quantel Mirage system at Broadway Video in New York City. At left, one of Broadway Video's post-production suites with Mirage control panel interfaced with editor and production switcher.

Premore, Inc., a broadcast production and post-production facility in Los Angeles, has purchased five Sony BVH-2000 VTRS and six BVU-800 U-Matic VTRS . . . Alan Landsburg Productions has added a new production facility with an editing suite designed by Centro Corp. The new facility was built for *That's Incredible* and contains five Sony BVU-800s and one BVU-820.

RCA has announced that it will offer 30 mm diode gun Leddicon pickup tubes, manufactured by EEV, as an option for the standard tubes in the TK-47B automatic studio camera.

WRAL-TV in Raleigh, NC is using the Dubner CBG 2 for the creation of weather maps for its daily broadcasts . . . Ruxton Ltd., a Burbank post-production house, uses the CBG 2 for graphics and screen animation on the NBC series *Knightrider*.

The EMCEE Systems Group will direct the updating and addition of a turnkey order from Cascade Pacific for its LPTV facility . . . Summit Communications has placed an order with EMCEE for an MDS TV transmitter to be installed in Gillette, WY.

Trident and Fedco Audio Labs have installed the Series 80, 32x24 console in the Fedco mobile unit, located in Providence, RI . . . Nashville's Scene Three debuted its new \$1.5 million mobile teleproduction center and is now producing national programming for Multimedia and the General Television Network . . .

The Media Group of Grand Rapids, MI is expanding its one-inch post-production capability with Hitachi 200-B VTRS, a Datatron Vanguard editor, a Quantel 5000 SP, and a 3M 8800 character generator.

Robert Bosch GmbH, International

electronics equipment manufacturer, has regained the right to use the name Bosch in the United States after reaching an agreement with United Technologies Corp.

Netcom International has leased four transponders on RCA Satcom 1-R, and will begin leasing two of the four transponders around June.

A QuantaNews computer-assisted newswriting and management system has been installed by Quanta at WTLV, an ABC affiliate in Jacksonville, FL . . . Business Times, the newly announced cable programmer, will computerize its news operation with a Mini Fury from Basys.

Producers Color Service of Southfield, MI recently brought on-line an Ahpex Aural Exciter type B for its audio post-production studio . . . KPIX-TV in San Francisco has purchased two Shibasoku color monitors for its master production facility.

Kliegl Brothers Lighting has engaged Entertainment Technology to provide for the development of its new lighting control systems . . . Crown has named a new Canadian distributor, A.C. Simmonds & Sons . . . Logitek Electronic Systems has added three more dealers: Tritronics in San Diego, Spencer Broadcast in Phoenix, and Broadcast Equipment of Bluff City, TN . . . Antenna Technology signed an agreement with Crown Communications to distribute the Simulstat and Trisat product line.

Global Video of Orlando, FL and Global Vision in Hollywood, CA have made available, free of charge, an international color-coded map to identify the countries of the world who use NTSC, PAL, PAL-M, and SECAM.

Dalsat has unveiled a commercial Ku-band transportable earth station in use at NBC's Burbank studios . . . The Satellite Transmission Systems division of California Microwave has been awarded two large contracts. One, for \$4.7 million, is from Comsat for integration and testing of new Intelsat earth stations, and the other is for \$7.3 million to provide Allstate Communications with earth station equipment.

John Williamson was promoted by Sound Technology to the position of president . . . Satellite Television Corp. made two personnel moves: John Hannon was named vp and general counsel and Warren Zeger is the new vp for planning and business development . . . Edina Gillmor was appointed by United Satellite Communications as the new director of marketing services.

Frezzi™ "High-Tech" fast-charge all-purpose battery.

Full 4aH capacity provides longer run-times for VTRs, cameras & lights. Direct replacement for your old BP-90s.

For information call (201) 427-1160



Frezzolini Electronics Inc.

7 Valley St. Hawthorne, N.J. 07506 • TWX: 710-988-4142

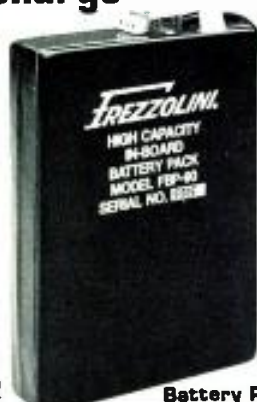

NEW
exclusive

Extra output connector for portable lights.

Made in U.S.A.

Battery Pack Model FBP-90FC

Circle 250 on Reader Service Card



Vidifont® Graphics V. Performance that's picture perfect.

Picture crisp, clean, coordinated graphics that capture attention, provide information and create a distinct perspective that sets you apart.

Picture the Vidifont Graphics V. Combining the features and functions of character generation, graphics, animation and information displays into a single integrated system. All the creative tools you need for news, dial-up services such as satellite weather and sports, commercial spots, promos, elections and special programs.

Vidifont Graphics V allows multiple-user access of up to eight channels. On-line creativity is combined with off-line input, making it easy to update and display new information.

Vidifont. The picture of performance in over 500 TV and production studios around the world. Call or write Thomson-CSF Broadcast, Inc., 37 Brownhouse Rd., Stamford, CT 06902. Tel. (203) 965-7000. TWX (710) 474-3346. Telex 6819035-Answer Back 6819035 TCSB UW.

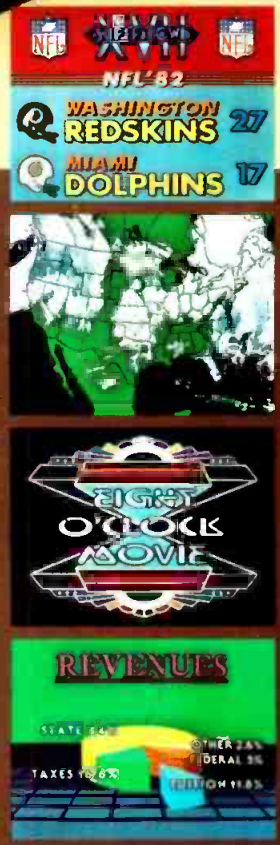

Circle 251 on Reader Service Card

This ultra-sophisticated Ward-Beck audio system for the Post Production Control Room at Group W's, KPIX, San Francisco, is the third of a series operating at their new station facilities.

Using top of the line Ward-Beck Series 460 modular components, its features include an integral routing switcher with alpha-numeric dot-matrix displays to indicate the status of the 48-input/24-output configuration.

This particular unit is employed on program post-production for Group W's highly successful, nationally syndicated *PM Magazine*.



First by Design.

Ward-Beck Systems Ltd.
841 Progress Avenue, Scarborough,
Ontario, Canada M1H 2X4.
Tel: (416) 438-6550.
Tlx: 065-25399.